

# CD3

## DIRECTIONAL CONTROL BANKABLE VALVE WITH D15 COILS

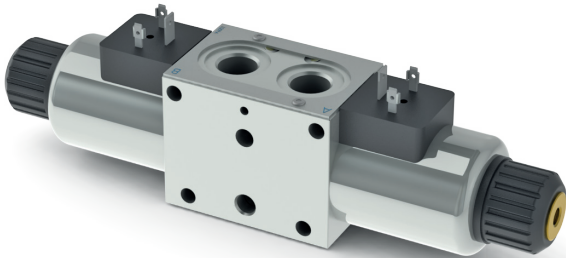

Directional control bankable valve CD3 with single or double solenoid.

- Centring achieved by means of calibrated length springs which immediately reposition the spool in the neutral position when the electrical signal is shut off.
- Different springs used for each spool to improve the valve performance.
- Emergency control.
- Body for parallel or series connections
- Threaded ports sizes G3/8" or 9/16"-18UNF (SAE 6), with or without LS line.
- Coils protection IP66
- Power supply DC or AC (with rectifier).
- Standard connectors DIN 43650 ISO 4400, AMP Junior, flying leads and Deutsch
- Maximum flow until 40 l/min.
- Cast iron zinc plated body.

Connector to be ordered separately, see page 86.

### ORDERING CODE

<b>CD</b>	Directional control bankable valve (with D15 coil)
<b>3</b>	Size
<b>*</b>	Body type (tab. 1)
<b>E</b>	Electrical operator
<b>**</b>	Spool (tab.2)
<b>*</b>	Mounting (tab.3)
<b>*</b>	Voltage (tab.4)
<b>**</b>	Variants (tab.5)
<b>2</b>	Serial No.

### FEATURES

Max. pressure ports P/A/B/T	310 bar
Max. pressure port T	250 bar
Max. Flow	40 l/min
Max excitation frequency	3 Hz
Duty cycle	100% ED
Hydraulic fluid	DIN 51524 Mineral oils
Fluid viscosity	10 ÷ 500 mm <sup>2</sup> /s
Fluid temperature	-25°C ÷ 75°C
Ambient temperature	-25°C ÷ 60°C
Max. contamination level (filter $\beta_{25} \geq 75$ )	ISO 4406:1999: class 21/19/16 NAS 1638: class 10
Weight with one DC solenoid	1.389 kg
Weight with two DC solenoids	1.778 kg

## ORDERING CODE

**Tab.1 - Body type**

Code	Body
<b>A</b>	Ports G3/8" parallel
<b>B</b>	Ports 9/16" - 18UNF parallel
<b>D</b> (1)	Ports G3/8" series
<b>E</b> (1)	Ports 9/16" - 18UNF series
<b>G</b>	Attachment style Parallel presetting for modular valves
<b>H</b> (1)	Attachment style Series presetting for modular valves
<b>L</b>	Ports G3/8" parallel - LS vers.
<b>M</b>	Attachment style, parallel-LS vers. Presetting for modular valves
<b>S</b>	Special connection B-P-A (see outlet module unit FUS3 pag .53)
<b>U</b>	Ports G3/8" parallel - P-T closed (not require the outlet module units)

**Tab.2 - Standard spools**

Two solenoids, spring centred "C" Mounting			
Code		Covering	Transient position
<b>01</b>		+	
<b>02</b>		-	
<b>03</b>		+	
<b>04</b> (2)		-	

One solenoid, side A "E" Mounting			
Code		Covering	Transient position
<b>01</b>		+	
<b>02</b>		-	
<b>03</b>		+	
<b>04</b> (2)		-	
<b>15</b>		-	
<b>16</b>		+	

One solenoid, side B "F" Mounting			
Code		Covering	Transient position
<b>01</b>		+	
<b>02</b>		-	
<b>03</b>		+	
<b>04</b> (2)		-	
<b>15</b>		-	
<b>16</b>		+	

**Tab.3 - Mounting**

Code	Symbol
<b>C</b>	
<b>E</b>	
<b>F</b>	
<b>G</b> (2)	
<b>H</b> (2)	

**Tab.4 - Coils D15 voltage (7)**

Code	Voltage	Max. winding temperature (Ambient temperature 25°C)	Rated power W	Resistance @ 20°C (Ohm) ±10%
<b>L</b>	12 Vdc	110 °C	30	4.8
<b>M</b>	24 Vdc	110 °C	30	18.8
<b>V</b> (3)	28 Vdc	110 °C	30	25.6
<b>N</b> (3)	48 Vdc	110 °C	30	75.2
<b>Z</b> (4)	102 Vdc	110 °C	30	340
<b>P</b> (3)	110 Vdc	110 °C	30	387
<b>X</b> (5)	205 Vdc	110 °C	30	1375
<b>W</b> (6)	Without coils			

**Tab.5 - Variants (7-8)**

Code	Variant
<b>S1</b>	No variant
<b>SV</b>	Viton
<b>LF</b> (12)	Emergency control lever (see page 38)
<b>LR</b>	Emergency control lever 180° rotated (see page 38)
<b>ES</b>	Emergency button (see page 38)
<b>P2</b> (9)	Rotary emergency button (see page 38)
<b>R5</b> (9)	Rotary emergency b. 180° (see page 38)
<b>3T</b>	First elem. for series connec.
<b>AJ</b> (10)	AMP Junior connection (see page 89)
<b>AD</b> (10)	AMP Junior and integr diode (see page 89)
<b>SL</b> (10)	Coil with flying leads 175 mm (see page 89)
<b>CZ</b> (10)	Deutsch DT04-2P connection (see page 90)
<b>R6</b> (10)	Deutsch DT04-2P connection eCoat surface treatment (see page 90)
<b>RS</b> (11)	Hirschmann coil eCoat surface treatment (see page 90)

- (1) For series connection configuration, a special individual bankable valve CD3\*E04\*\*3T2 (A B or G parallel body type only, with spool 04 type, 3T variant) must always be used as first element. For other individual bankable valve must use body D E or H connector series type with spool 04 only
- (2) Specials with price increasing
- (3) Special voltage
- (4) Require connector with rectifier: 115 VAC/50Hz - 120 VAC/60Hz
- (5) Require connector with rectifier: 230 VAC/50Hz - 240 VAC/60Hz
- (6) Performance are guaranteed only using valves completed with BFP coil
- (7) Connector to be ordered separately, see page 86;  
Coils technical data, see page 89 - 90;  
Voltage codes are not stamped on the plate, their are readable on the coils
- (8) Other variants available on request
- (9) Tightening torque max. 6-9 Nm (CH n. 22)
- (10) Available in 12V or 24V DC voltage only.
- (11) Available in 12V, 24V, 28V or 110V DC voltage only
- (12) For the body type G - H - M order LR variant (Emergency control lever 180° rotated)

# CD3

## HYDRAULIC SYMBOLS

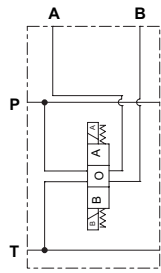

CD3 A ... CD3 B ...

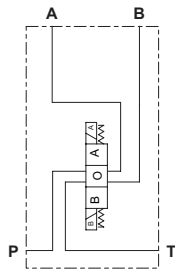

CD3 D ... CDC3 E ...

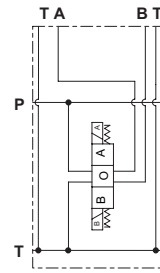

CD3 G ...

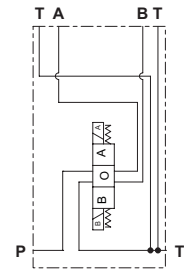

CD3 H ...

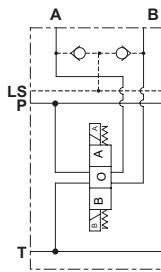

CD3 L ...

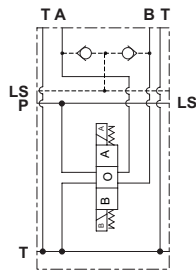

CD3 M ...

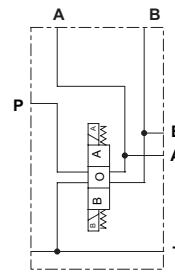

CDC3 S ...

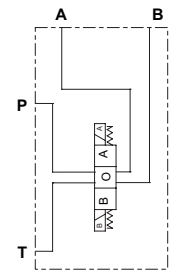

CDC3 U ...

## HYDRAULIC SYMBOLS AND INSTRUCTION OF CONNECTION

### PARALLEL CONNECTION

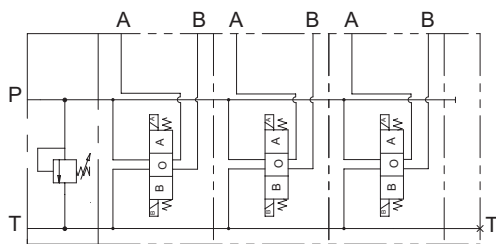
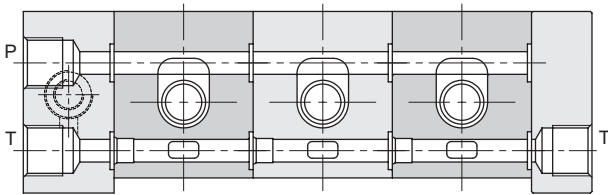

### SERIES CONNECTION

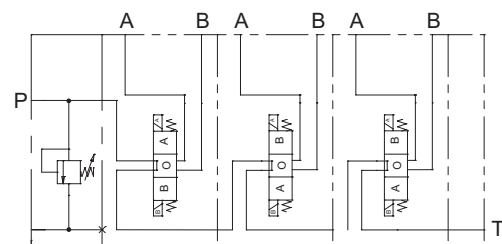
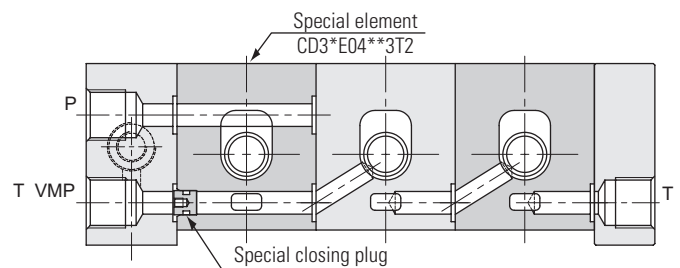

For series connection configuration, a special individual valve connection section (CD3\*E04\*\*3T2) must always be used as first element (see ordering code page 33).

## PRESSURE DROPS - DIRECTIONAL CONTROL BANKABLE VALVE

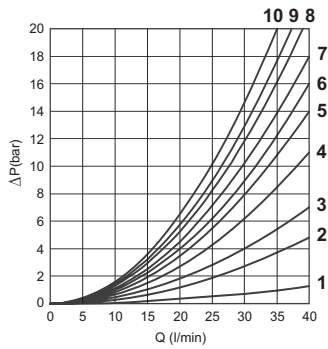

Spool type	Connections					
	P → A	P → B	A → T	B → T	P → T	P/T passing
01	6	6	6	6	—	1
02 (p)	5	5	4	4	2	1
02 (s)	5	5	5	5	3	—
03	6	6	5	5	—	1
04 (p)	9	10	8	8	4	1
04 (s)	9	9	8	8	5	—
15-16 (E)	5	7	5	9	—	1
15-16 (F)	7	5	9	5	—	1

Curve No.

The diagram at the side shows the pressure drop curves for spools during normal usage. The fluid used is a mineral oil with a viscosity of 46 mm<sup>2</sup>/s at 40 C°; the tests have been carried out at a fluid temperature of 40 C°.

(p) Parallel connections  
 (s) Series connections  
 (E) Mounting E  
 (F) Mounting F

## LIMITS OF USE (MOUNTING C-E-F)

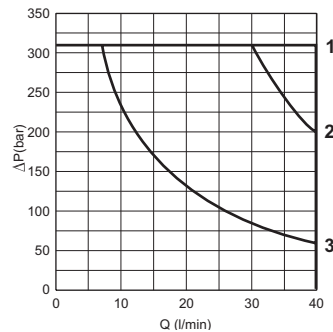

Spool type	Curve No.
01	1
02	1
03	1
04	2
15	3
16	1

(3) = 16 spools used as 2 or 3 way, follow the curve No. 3

The tests have been carried out with solenoids at operating temperature and a voltage 10% less than rated voltage with a fluid temperature of 50 C°. The fluid used was a mineral oil with a viscosity of 46 mm<sup>2</sup>/s at 40 degrees C. The values in the diagram refer to tests carried out with the oil flow in two directions simultaneously (e.g. from P to A and at the same time B to T).

**In the cases where valves 4/2 and 4/3 are used with the flow in one direction only, the limits of use could have variations which may even be negative (See curve No 3 and Spool No 16 used as 2 or 3 ways). The tests were carried out with a counter-pressure of 2 bar at T port.**

**NOTE: The limits of use are valid for the C, E, F mounting.**

## OVERALL DIMENSIONS

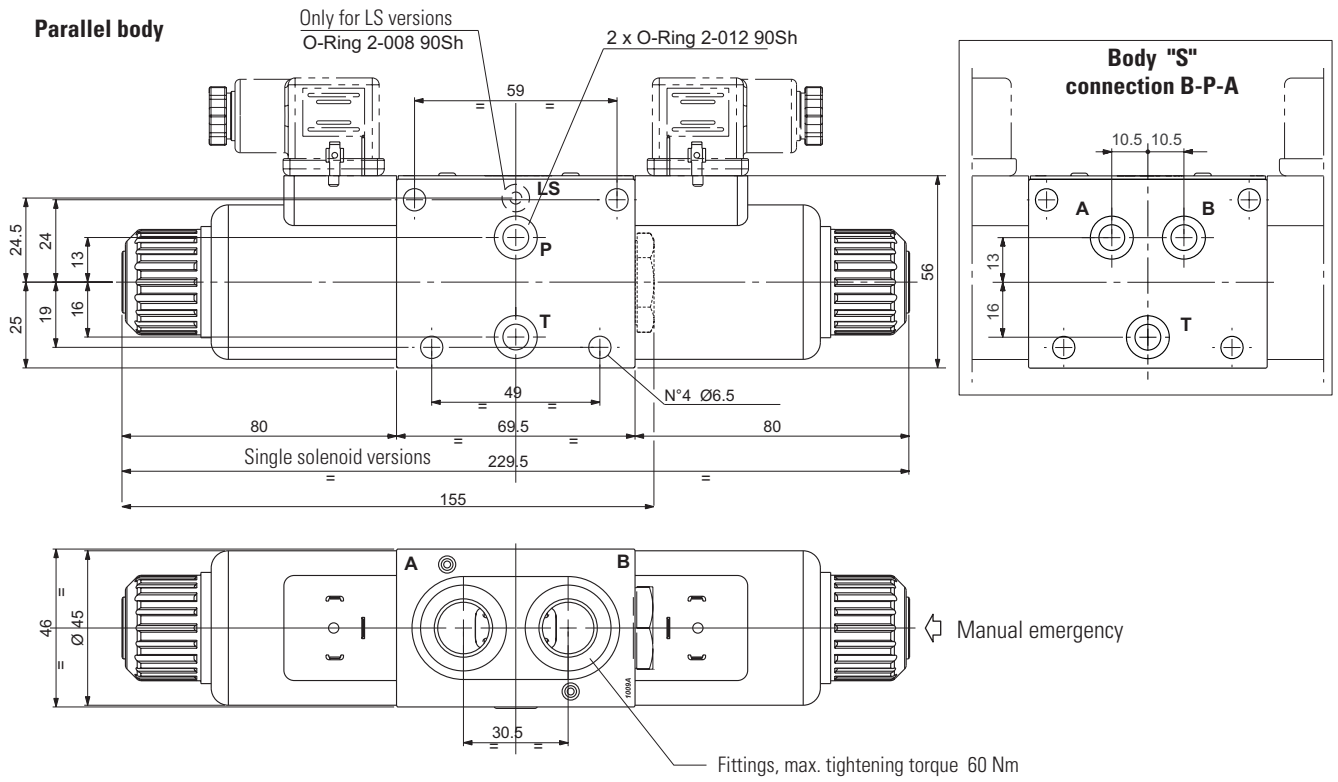

### Parallel body Presetting for modular valves

