

ST - Suction strainers D - Diffusors

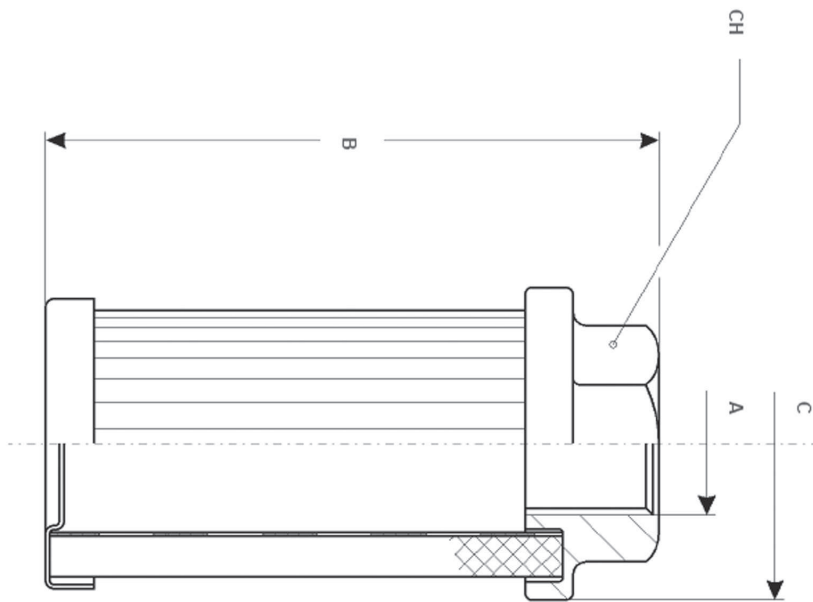

DIFFUSORS

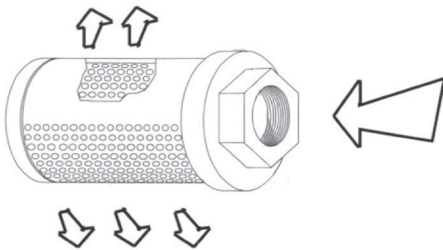

ST SUCTION STRAINERS

Filter to be mounted on the pump suction line for flow from 25 to 200 lt/min. Standard filtration media is 12 µm, AISI 304 stainless steel mesh. Other micron rating and by-pass valve available on request.

D DIFFUSORS

Diffusors are useful to slow down oil speed when it is returning to the tank. They greatly reduce noise level, turbulence and foaming problems in the oil tank.

Type	Lt/min	A BSPP/NPT	B	C	CH
ST-14	12	¼"	90	46	24
ST-38	12	⅜"	90	46	24
ST-12	15	½"	105	46	30
ST-34	25	¾"	109	64	36
ST-100A	50	1"	139	64	46
ST-100B	80	1"	139	86	52
ST-114	90	1 ¼"	139	86	52
ST-112A	95	1 ½"	139	86	60
ST-112B	130	1 ½"	200	86	60
ST-112C	220	1 ½"	151	150	70
ST-200A	180	2"	260	86	70
ST-200B	225	2"	151	150	70
ST-212	350	2 ½"	211	150	90
ST-300	500	3"	272	150	100

ORDERING CODE

ST 200A 90

1 2 3

1 - ST for suction strainers D for diffusors

2 - Size and connection (see table)

3 - Filtration rating (see tab. 01.2)

90 µm
125 µm
300 µm

Why is filtration essential?

Even when you project and make the best possible hydraulic system as soon as you start using it the contamination already present and constantly generated will wear and eventually permanently damage the whole system.

The only protection to avoid this is to keep contamination level under control. The better you do it the longer system life will be.

Few words about contamination

When examining what contamination is we must admit we're facing a random and complex world. Just consider:

- from the beginning all possible kind of dirt, like: dust, textile and/or paper parts (mainly used to clean!)

rust, paint, metal and plastic particles left when assembling the components together, etc...

- in working conditions metal and plastic/rubber wear particles generated by components frictions (plastics parts, besides, expanding and melting with temperature increases).

Dust introduced by air going into the system.

Chemical reactions of the various parts amongst the and in presence of air.

A major problem is the random form of the contaminant particles

All we can realistically do, in these conditions, is to classify filter efficiency by means of a repeatable test (general conditions and procedures are fixed) called multipass test (as per ISO 4406:1999).

The contaminant, though, is of spherical forms (although of various sizes) and this does not correspond to the average real contaminant particles form.

The test basically gives two parameters:

Beta ratio, where $\beta_x = \frac{x_{in}}{x_{out}}$ and "x" means a determined particle size expressed in μm (10-6 meters in diameter).

I.E.: considering a beta ratio for particle size 10 μm , having 105 particles "in" and 103 "out" our

$$\beta_{10} = \frac{105}{103} = 10^2 = 100$$

filtration efficiency (Given in %) = $100 - (100/\beta_x)$

- I.E.
- $\beta_x = 2$ means 50%
 - $\beta_x = 20$ means 25%
 - $\beta_x = 75$ means 98,67%
 - $\beta_x = 100$ means 99%

TAB. 01.2	
6F	6 μm FIBER GLASS
10F	10 μm FIBER GLASS
25F	25 μm FIBER GLASS
10	10 μm PAPER
25	25 μm PAPER
60	60 μm SQUARE MESH
90	90 μm SQUARE MESH
125	125 μm SQUARE MESH

*other filtration ratings available on request

Which filter?

Hydraulic and air filters are used to keep under control the contamination level of an hydraulic system. Depending on their location in the system, the filters are commonly classified as follows:

Return line filters: located downstream of all "working" components they assure a general, constant, system contamination level. Consequently indirectly protecting all the components to a specific contamination size. They should be sized to guarantee a high dirt holding capacity (maximizing the time of their life). Elements should assure a filtration efficiency $\beta_x \geq 75$ and filtration ratings ("x") to be in the range 10 to 25 μm .

Inline Filters: installed on the pressure line, they directly protect one or more component. Elements should have a $\beta_x \geq 75$ (where "x" ranges between 3, to 10 μm).

Suction filters: mounted on the pump inlet line, protect the pump from coarse contaminants. The elements are commonly made in metal mesh. Special care must be taken to avoid pump cavitation. Typical "X" value being 125, and sometimes 60 μm .

Air filters: keeping in-coming air contamination in the oil tank to (or below) 10 μm .

Pressure drop

Next step is to choose the right filter dimension. To do this please refer to our filter flow rate-pressure drop graphs.

Pressure drop values are always given for the complete filter oil viscosity is referred for hydraulic oil VG46 at working temp. Of course an higher or lower viscosity is automatically modifying the general filter performance. In case of any dubt please contact us.

When sizing the right filter it's a good rule to comply to the recommended fluid speed:

Suction line from 1 to 1 m/s

Return line from 1.5 to 4 m/s

Pressure (inline) from 5 to 10 m/s

Finally, a dirt element warning device (clogging indicator) is greatly helping to avoid incorrect maintenance, and consequent permanent damage of the hydraulic system components. Clogging indicator used are visual or electric (or both together).

Note: we expertize in filtration and are always keen to evaluate the production of special filters, even for small quantities. Should this be of your interest, please do not hesitate to contact us.