

# VIVOIL

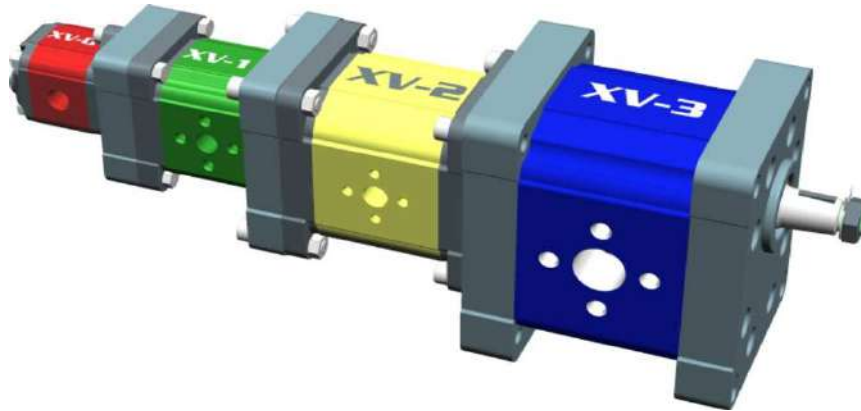

ENGLISH

## Unidirectional Motors



<b>XV-0P</b>	<b>Unidirectional Pump</b>
<b>XV-1P</b>	Left Rotation
<b>XV-2P</b>	Right Rotation
<b>XV-3P</b>	

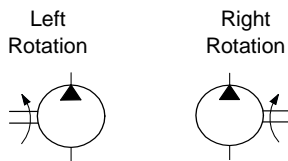

<b>XV-0U</b>	<b>Unidirectional Motor</b>
<b>XV-1U</b>	Left Rotation
<b>XV-2U</b>	Right Rotation
<b>XV-3U</b>	

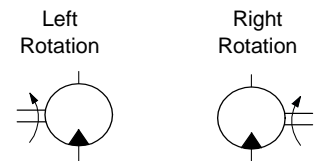

<b>XV-0R</b>	<b>Reversible Pump</b>
<b>XV-1R</b>	External drainage
<b>XV-2R</b>	Internal drainage
<b>XV-3R</b>	

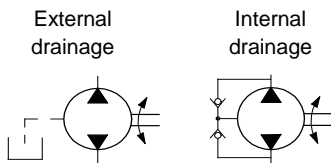

<b>XV-0M</b>	<b>Reversible Motor</b>
<b>XV-1M</b>	External drainage
<b>XV-2M</b>	Internal drainage
<b>XV-3M</b>	

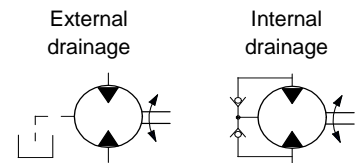

<b>XV-0T</b>	<b>XV-1T</b>	<b>XV-2T</b>	<b>XV-3T</b>	<b>Primary element of multiple pump</b>
<b>XV-0I</b>	<b>XV-1I</b>	<b>XV-2I</b>	<b>XV-3I</b>	<b>Intermediate element of multiple pump</b>
<b>XV-0F</b>	<b>XV-1F</b>	<b>XV-2F</b>	<b>XV-3F</b>	<b>Final element of multiple pump</b>

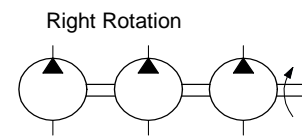
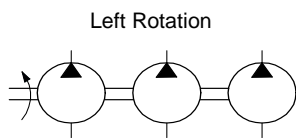

<b>KV-DF</b>	<b>Flow divider</b>
--------------	---------------------

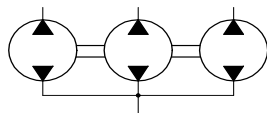

<b>KV-DFV</b>	<b>Flow divided with valves</b>
---------------	---------------------------------

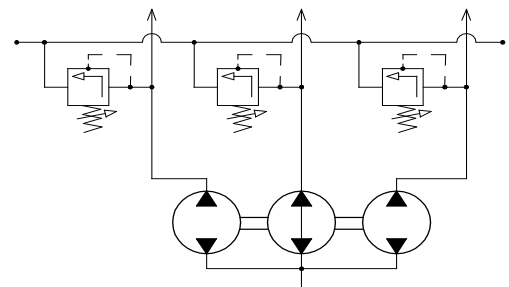

<b>KV-DF+M</b>	<b>Flow divider with motor</b>
----------------	--------------------------------

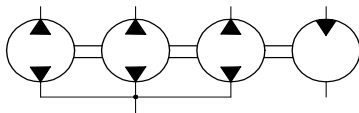

The descriptions and dimensions stated herein are not binding. Vivoil Oleodinamica Vivolo s.r.l reserves the right to make changes as it deems necessary, at any time and without notice.

Introduction	7
Summary: Displacements - Pressures - Speeds	9
General technical data	10
Torques allowed on shaft	12
Useful calculation formulas	13
Characteristic Curves	14
Changing the direction of pump rotation - group 0	18
Changing the direction of pump rotation - group 1	19
Changing the direction of pump rotation - group 2	23
Changing the direction of pump rotation - group 3	28

**XV-0U**



XU001

STANDARD MOTOR

ø22 FLANGE - PARALLEL SHAFT

30



XU012

BH TYPE MOTOR

ø22 BODY-SHAPED FLANGE - MILLED SHANK

32

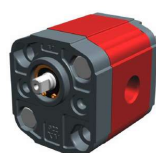

XU017

HY TYPE MOTOR

ø22 BODY-SHAPED FLANGE - MILLED SHANK

34

**XV-1U**



XU101

STANDARD EUROPEAN MOTOR

ø25.4 FLANGE - TAPER SHAFT

36





XU105

STANDARD EUROPEAN MOTOR

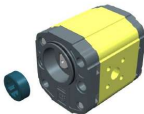

ø25.4 FLANGE - TAPER SHAFT

38

	<b>XU113</b>	<b>STANDARD MOTOR</b> <b>ø30 FLANGE - TAPER SHAFT</b>	<b>40</b>
<hr/>			
	<b>XU119</b>	<b>BH TYPE MOTOR</b> <b>ø32 BODY-SHAPED FLANGE - MILLED SHANK</b>	<b>42</b>
<hr/>			
	<b>XU140</b>	<b>HY TYPE MOTOR</b> <b>ø32 BODY-SHAPED FLANGE - MILLED SHANK</b>	<b>44</b>
<hr/>			
	<b>XU161</b>	<b>STANDARD GERMAN "BH" TYPE MOTOR</b> <b>ø32 BODY-SHAPED FLANGE - MILLED SHANK</b>	<b>46</b>
<hr/>			
	<b>XU168</b>	<b>SAE AA TYPE MOTOR</b> <b>ø50.8 FLANGE - PARALLEL SHAFT</b>	<b>48</b>
<hr/>			
			<b>XV-2U</b>
	<b>XU201</b>	<b>STANDARD EUROPEAN MOTOR</b> <b>ø36.5 FLANGE - TAPER SHAFT</b>	<b>50</b>
<hr/>			
	<b>XU207</b>	<b>STANDARD EUROPEAN MOTOR</b> <b>ø36.5 FLANGE - TAPER SHAFT</b>	<b>52</b>
<hr/>			
	<b>XU210</b>	<b>BH TYPE MOTOR</b> <b>ø50 BODY-SHAPED FLANGE - TAPER SHAFT</b>	<b>54</b>
<hr/>			
	<b>XU213</b>	<b>HY TYPE MOTOR</b> <b>ø50 BODY-SHAPED FLANGE - TAPER SHAFT</b>	<b>56</b>
<hr/>			

	<b>XU216</b>	<b>STANDARD GERMAN "BH" TYPE MOTOR</b> <b>ø52 BODY-SHAPED FLANGE - MILLED SHANK</b>	<b>58</b>
	<b>XU217</b>	<b>STANDARD GERMAN MOTOR</b> <b>ø80 FLANGE - TAPER SHAFT</b>	<b>60</b>
	<b>XU219</b>	<b>SAE A TYPE MOTOR</b> <b>ø82.5 FLANGE - SPLINED SHAFT</b>	<b>62</b>

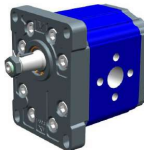
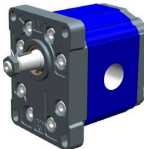
**XV-3U**

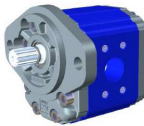
	<b>XU301</b>	<b>STANDARD EUROPEAN MOTOR</b> <b>ø50.8 FLANGE - TAPER SHAFT</b>	<b>64</b>
	<b>XU302</b>	<b>STANDARD EUROPEAN MOTOR</b> <b>ø50.8 FLANGE - TAPER SHAFT</b>	<b>66</b>
	<b>XU331</b>	<b>SAE B TYPE MOTOR</b> <b>ø101.6 FLANGE - SPLINED SHAFT</b>	<b>68</b>
	<b>XU332</b>	<b>SAE B TYPE MOTOR</b> <b>ø101.6 FLANGE - SPLINED SHAFT</b>	<b>70</b>

<b>APPENDIX - Special Versions</b>	<b>72</b>
<b>Max. Pressure Valves</b>	<b>74</b>
<b>Unions</b>	<b>75</b>
<b>Table of seals OR</b>	<b>77</b>
<b>Table of oil speeds</b>	<b>78</b>
<b>Table of Areas and Perimeters</b>	<b>79</b>











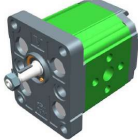

## UNIDIRECTIONAL MOTORS

### Index

Pressure conversion table	80
Conversion table	81
Table of oil viscosity according to temperature	82
Table of pressure drops	83
Table of Elements	84
Table of chemical resistance of elastomers	85
Table of mechanical features of elastomers	86
Table of tapping holes	87
Map	90

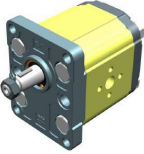
<b>XV-0U</b>		
		
References: XU-001	References: XU-012	References: XU-017
<b>Standard Ø22 FLANGE</b>	<b>Ø22 BH FLANGE</b>	<b>Ø22 HY FLANGE</b>

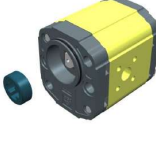
<b>XV-1U</b>		
		
References: XU-101	References: XU-113	References: XU-119
<b>Ø25.4 FLANGE</b>	<b>Ø30 FLANGE</b>	<b>Ø32 BH FLANGE</b>
		
References : XU-140	References: XU-161	References: XU-168
<b>Ø32 HY FLANGE</b>	<b>Standard German Ø32 BH</b>	<b>Ø50.8 SAE AA FLANGE</b>

<b>XV-2U</b>		
		
References : XU-201	References : XU-210	References: XU-213
<b>Ø36.5 FLANGE</b>	<b>Ø50 BH FLANGE</b>	<b>Ø50 HY FLANGE</b>
		
References: XU-216	References : XU-217	References : XU-219
<b>Standard German Ø52 BH FLANGE</b>	<b>Standard German Ø80 FLANGE</b>	<b>Ø82.5 SAE A FLANGE</b>

<b>XV-3P</b>	
	
References : XU-301	References : XU-331
<b>FLANGE Ø50,8 - Standard</b>	<b>FLANGE Ø101,6 SAE B</b>

**Vivoil Oleodinamica**

**Vivolo s.r.l.** presents a new series of gear motors called **XV-U**.

The quality of the product has been improved on by exploiting new and innovative solutions, both technical and constructive, for which the company has been **awarded 3 patents**.

The motors are divided into four groups:

**XV-0U** **XV1-U** **XV-2U** **XV-3U**

**The main features of the XV-0U are the following:**

Displacements from 0.45 cm<sup>3</sup> / revolution to 2.28 cm<sup>3</sup>/revolution.  
Maximum pressures up to **280 bar**.  
Versions w/ flanges: Ø22 – Standard;  
                                  Ø22 BH – Sagomata;  
                                  Ø22 HY – Sagomata.  
Rotation speeds up to **9000 rpm**.  
Configurations with inlet and outlet in the body, flange and cover.  
Available shafts:     Cylindrical with Woodruff key;  
Milled shank;  
Tapered 1:8 Woodruff key.

---

**The main features of the XV-1U are the following:**

Displacements from 0.91 cm<sup>3</sup> / revolution to 9.88 cm<sup>3</sup>/ revolution.  
Maximum pressures up to **300 bar**.  
Versions w/ flanges: Ø25.4 – Standard European;  
                                  Ø30 – Standard;  
                                  Ø32 BH – Body-Shaped;  
                                  Ø32 HY – Body-Shaped;  
                                  Ø32 BH – Standard German – Body-Shaped;  
                                  Ø50.8 – SAE AA  
Rotation speeds up to **6000 rpm**  
Configurations with inlet and outlet in the body, flange and cover.  
Available shafts:     Tapered 1:8 Woodruff key;  
                                  Parallel with key;  
Milled shank;  
Splined.

---

**The main features of the XV-2U are the following:**

Displacements from 4.2 cm<sup>3</sup> / revolution a 39.6 cm<sup>3</sup>/ revolution.  
Maximum pressures up to **300 bar**.  
Versions w/ flanges: Ø36,5 – Standard Europea;  
                                  Ø50 BH – Body-Shaped;  
                                  Ø50 HY – Body-Shaped;  
                                  Ø52 BH - Standard German – Body-Shaped;  
                                  Ø80 – Standard German;  
                                  Ø82,5 – SAE A.  
Rotation speeds up to **3500 rpm**  
Configurations with inlet and outlet in the body, flange and cover.  
Available shafts:     Tapered 1:8 Woodruff key;  
                                  Parallel with key;  
Milled shank;  
Splined.

---

**The main features of the XV-3U are the following:**

Displacements from 14.89 cm<sup>3</sup> / revolution to 86.87cm<sup>3</sup>/ revolution.  
Maximum pressures up to **320 bar**.  
Versions w/ flanges: Ø50,8 – Standard European;  
Rotation speeds up to **3000 rpm**.  
Available shafts:     Tapered 1:8 Woodruff key;  
                                  Parallel with key;  
Splined.

**Summary: Displacements - Torque - Power - Pressures - Speeds**

	TYPE	Displacement	Torque	Power	Max Inlet Pressure	Max Outlet Pressure	Min Starting Pressure	Min Speed	Max Speed
			1000 rev/min	100 bar					
<b>XV-0U</b>	XV-0U/0.45	0.45 cm <sup>3</sup> /rev	0,61 Nm	0,06 KW	280 bar	1 bar	25 bar	700 rev/min	9000 rev/min
	XV-0U/0.57	0.56 cm <sup>3</sup> /rev	0,76 Nm	0,08 KW	280 bar	1 bar	25 bar	700 rev/min	9000 rev/min
	XV-0U/0.76	0.75 cm <sup>3</sup> /rev	1,01 Nm	0,11 KW	280 bar	1 bar	25 bar	700 rev/min	9000 rev/min
	XV-0U/0.98	0.92 cm <sup>3</sup> /rev	1,24 Nm	0,13 KW	280 bar	1 bar	20 bar	700 rev/min	6000 rev/min
	XV-0U/1.27	1.26 cm <sup>3</sup> /rev	1,70 Nm	0,18 KW	280 bar	1 bar	15 bar	700 rev/min	6000 rev/min
	XV-0U/1.52	1.48 cm <sup>3</sup> /rev	2,00 Nm	0,21 KW	280 bar	1 bar	10 bar	700 rev/min	6000 rev/min
	XV-0U/2.30	2.28 cm <sup>3</sup> /rev	3,08 Nm	0,32 KW	210 bar	1 bar	10 bar	700 rev/min	5000 rev/min
<b>XV-1U</b>	XV-1U/0.9	0.91 cm <sup>3</sup> /rev	1,23 Nm	0,13 KW	280 bar	6 bar	30 bar	700 rev/min	6000 rev/min
	XV-1U/1.2	1.17 cm <sup>3</sup> /rev	1,58 Nm	0,17 KW	290 bar	6 bar	30 bar	700 rev/min	6000 rev/min
	XV-1U/1.7	1.56 cm <sup>3</sup> /rev	2,11 Nm	0,22 KW	290 bar	6 bar	30 bar	700 rev/min	6000 rev/min
	XV-1U/2.2	2.08 cm <sup>3</sup> /rev	2,81 Nm	0,29 KW	290 bar	6 bar	25 bar	700 rev/min	6000 rev/min
	XV-1U/2.6	2.60 cm <sup>3</sup> /rev	3,52 Nm	0,37 KW	300 bar	6 bar	20 bar	700 rev/min	6000 rev/min
	XV-1U/3.2	3.12 cm <sup>3</sup> /rev	4,22 Nm	0,44 KW	300 bar	6 bar	15 bar	700 rev/min	6000 rev/min
	XV-1U/3.8	3.64 cm <sup>3</sup> /rev	4,92 Nm	0,52 KW	300 bar	6 bar	15 bar	700 rev/min	6000 rev/min
	XV-1U/4.3	4.16 cm <sup>3</sup> /rev	5,63 Nm	0,59 KW	300 bar	6 bar	15 bar	700 rev/min	6000 rev/min
	XV-1U/4.9	4.94 cm <sup>3</sup> /rev	6,68 Nm	0,70 KW	300 bar	6 bar	15 bar	700 rev/min	6000 rev/min
	XV-1U/5.9	5.85 cm <sup>3</sup> /rev	7,91 Nm	0,83 KW	300 bar	6 bar	15 bar	700 rev/min	5000 rev/min
	XV-1U/6.5	6.50 cm <sup>3</sup> /rev	8,79 Nm	0,92 KW	300 bar	6 bar	10 bar	700 rev/min	5000 rev/min
	XV-1U/7.8	7.54 cm <sup>3</sup> /rev	10,20 Nm	1,07 KW	260 bar	6 bar	10 bar	700 rev/min	5000 rev/min
	XV-1U/9.8	9.88 cm <sup>3</sup> /rev	13,37 Nm	1,40 KW	230 bar	6 bar	10 bar	700 rev/min	4000 rev/min
<b>XV-2U</b>	XV-2U/4	4.2 cm <sup>3</sup> /rev	5,68 Nm	0,60 KW	300 bar	6 bar	30 bar	700 rev/min	3500 rev/min
	XV-2U/6	6.0 cm <sup>3</sup> /rev	8,12 Nm	0,85 KW	300 bar	6 bar	25 bar	700 rev/min	3500 rev/min
	XV-2U/9	8.4 cm <sup>3</sup> /rev	11,36 Nm	1,19 KW	300 bar	6 bar	20 bar	700 rev/min	3500 rev/min
	XV-2U/11	10.8 cm <sup>3</sup> /rev	14,61 Nm	1,53 KW	300 bar	6 bar	20 bar	700 rev/min	3500 rev/min
	XV-2U/14	14.4 cm <sup>3</sup> /rev	19,48 Nm	2,04 KW	290 bar	6 bar	15 bar	700 rev/min	3500 rev/min
	XV-2U/17	16.8 cm <sup>3</sup> /rev	22,73 Nm	2,38 KW	270 bar	6 bar	15 bar	700 rev/min	3500 rev/min
	XV-2U/19	19.2 cm <sup>3</sup> /rev	25,97 Nm	2,72 KW	250 bar	6 bar	15 bar	700 rev/min	3000 rev/min
	XV-2U/22	22.8 cm <sup>3</sup> /rev	30,84 Nm	3,23 KW	240 bar	6 bar	15 bar	700 rev/min	3000 rev/min
	XV-2U/26	26.2 cm <sup>3</sup> /rev	35,44 Nm	3,71 KW	210 bar	6 bar	15 bar	700 rev/min	3000 rev/min
	XV-2U/30	30.0 cm <sup>3</sup> /rev	40,58 Nm	4,25 KW	200 bar	6 bar	15 bar	700 rev/min	2500 rev/min
	XV-2U/34	34.2 cm <sup>3</sup> /rev	46,27 Nm	4,85 KW	190 bar	6 bar	15 bar	700 rev/min	2500 rev/min
	XV-2U/40	39.6 cm <sup>3</sup> /rev	53,57 Nm	5,61 KW	180 bar	6 bar	15 bar	700 rev/min	2000 rev/min
<b>XV-3U</b>	XV-3U/15	14.89 cm <sup>3</sup> /rev	20,14 Nm	2,11 KW	320 bar	6 bar	20 bar	700 rev/min	3000 rev/min
	XV-3U/18	17.37 cm <sup>3</sup> /rev	23,50 Nm	2,46 KW	320 bar	6 bar	20 bar	700 rev/min	3000 rev/min
	XV-3U/21	21.10 cm <sup>3</sup> /rev	28,54 Nm	2,99 KW	300 bar	6 bar	15 bar	700 rev/min	3000 rev/min
	XV-3U/27	26.97 cm <sup>3</sup> /rev	36,49 Nm	3,82 KW	270 bar	6 bar	10 bar	700 rev/min	3000 rev/min
	XV-3U/32	32.27 cm <sup>3</sup> /rev	43,66 Nm	4,57 KW	270 bar	6 bar	10 bar	700 rev/min	3000 rev/min
	XV-3U/38	38.47 cm <sup>3</sup> /rev	52,04 Nm	5,45 KW	270 bar	6 bar	10 bar	700 rev/min	2800 rev/min
	XV-3U/43	43.44 cm <sup>3</sup> /rev	58,77 Nm	6,15 KW	250 bar	6 bar	10 bar	700 rev/min	2800 rev/min
	XV-3U/47	47.16 cm <sup>3</sup> /rev	63,80 Nm	6,68 KW	250 bar	6 bar	10 bar	700 rev/min	2800 rev/min
	XV-3U/51	50.88 cm <sup>3</sup> /rev	68,83 Nm	7,21 KW	250 bar	6 bar	10 bar	700 rev/min	2800 rev/min
	XV-3U/54	54.60 cm <sup>3</sup> /rev	73,86 Nm	7,74 KW	250 bar	6 bar	10 bar	700 rev/min	2300 rev/min
	XV-3U/61	60.81 cm <sup>3</sup> /rev	82,26 Nm	8,61 KW	220 bar	6 bar	10 bar	700 rev/min	2300 rev/min
	XV-3U/64	64.53 cm <sup>3</sup> /rev	87,30 Nm	9,14 KW	220 bar	6 bar	10 bar	700 rev/min	2300 rev/min
	XV-3U/70	70.74 cm <sup>3</sup> /rev	95,70 Nm	10,02 KW	210 bar	6 bar	10 bar	700 rev/min	2300 rev/min
XV-3U/74	74.46 cm <sup>3</sup> /rev	100,73 Nm	10,55 KW	190 bar	6 bar	10 bar	700 rev/min	2300 rev/min	
XV-3U/90	86.87 cm <sup>3</sup> /rev	117,52 Nm	12,31 KW	160 bar	6 bar	10 bar	700 rev/min	2300 rev/min	

**General technical data**

Type of fluid to be used	Mineral-based hydraulic oil HLP HV (D IN 51524)
Minimum operating viscosity	10 mm <sup>2</sup> /s
Maximum operating viscosity	100 mm <sup>2</sup> /s
Maximum admissible viscosity at start-up	1500 mm <sup>2</sup> /s
Recommended viscosity	20 mm <sup>2</sup> /s - 100 mm <sup>2</sup> /s
Ambient temperature	-20 °C - 60°C
Fluid operating temperature	-15°C - 80°C
Recommended fluid operating temperature	30°C - 50° C
For temperatures above 120°C	Request FKM seals ( V iton)
Max. inlet fluid pressure (OUT)	0.3 - 0.5 bars (for higher pressures consult the manufacturer)
Inlet fluid filtering (IN)	30 - 60 Microns
Outlet fluid filtering (OUT)	10 - 25 Microns
Max. inlet fluid speed (IN)	0.5 - 1.5 m/s
Max. outlet fluid speed (OUT)	3.0 - 5.5m/s

**Flow rate tables**

TYPE	cm3/rev	Flow rate l/min	rpm															Flow rate l/min	
			700	1000	1500	2000	2500	3000	3500	4000	4500	5000	5500	6000	7000	8000	9000		
XV 0U/0.45	0,45	Flow rate l/min	0,299	0,428	0,641	0,855	1,069	1,283	1,496	1,710	1,924	2,138	2,351	2,565	2,993	3,420	3,848	Flow rate l/min	
XV 0U/0.57	0,56		0,372	0,532	0,798	1,064	1,330	1,596	1,862	2,128	2,394	2,660	2,926	3,192	3,724	4,256	4,788		
XV 0U/0.76	0,75		0,499	0,713	1,069	1,425	1,781	2,138	2,494	2,850	3,206	3,563	3,919	4,275	4,988	5,700	6,413		
XV 0U/0.98	0,92		0,612	0,874	1,311	1,748	2,185	2,622	3,059	3,496	3,933	4,370	4,807	5,244					
XV 0U/1.27	1,26		0,838	1,197	1,796	2,394	2,993	3,591	4,190	4,788	5,387	5,985	6,584	7,182					
XV 0U/1.52	1,48		0,984	1,406	2,109	2,812	3,515	4,218	4,921	5,624	6,327	7,030	7,733	8,436					
XV 0U/2.30	2,28		1,516	2,166	3,249	4,332	5,415	6,498	7,581	8,664	9,747	10,830							

TYPE	cm3/rev	Flow rate l/min	rpm											Flow rate l/min	
			700	1000	1500	2000	2500	3000	3500	4000	4500	5000	5500		6000
XV 1U/0.9	0,91	Flow rate l/min	0,630	0,900	1,350	1,800	2,250	2,700	3,150	3,600	4,050	4,500	4,950	5,400	Flow rate l/min
XV 1U/1.2	1,17		0,840	1,200	1,800	2,400	3,000	3,600	4,200	4,800	5,400	6,000	6,600	7,200	
XV 1U/1.7	1,56		1,190	1,700	2,550	3,400	4,250	5,100	5,950	6,800	7,650	8,500	9,350	10,200	
XV 1U/2.2	2,08		1,540	2,200	3,300	4,400	5,500	6,600	7,700	8,800	9,900	11,000	12,100	13,200	
XV 1U/2.6	2,6		1,820	2,600	3,900	5,200	6,500	7,800	9,100	10,400	11,700	13,000	14,300	15,600	
XV 1U/3.2	3,12		2,240	3,200	4,800	6,400	8,000	9,600	11,200	12,800	14,400	16,000	17,600	19,200	
XV 1U/3.8	3,64		2,660	3,800	5,700	7,600	9,500	11,400	13,300	15,200	17,100	19,000	20,900	22,800	
XV 1U/4.3	4,16		3,010	4,300	6,450	8,600	10,750	12,900	15,050	17,200	19,350	21,500	23,650	25,800	
XV 1U/4.9	4,94		3,430	4,900	7,350	9,800	12,250	14,700	17,150	19,600	22,050	24,500	26,950	29,400	
XV 1U/5.9	5,85		4,130	5,900	8,850	11,800	14,750	17,700	20,650	23,600	26,550	29,500			
XV 1U/6.5	6,5		4,550	6,500	9,750	13,000	16,250	19,500	22,750	26,000	29,250	32,500			
XV 1U/7.8	7,54		5,460	7,800	11,700	15,600	19,500	23,400	27,300	31,200	35,100	39,000			
XV 1U/9.8	9,88		6,860	9,800	14,700	19,600	24,500	29,400	34,300	39,200					

TYPE	cm3/rev		rpm							
			700	1000	1500	2000	2500	3000		3500
XV 2U/4	4,2	Flow rate l/min	2,800	4,000	6,000	8,000	10,000	12,000	14,000	Flow rate l/min
XV 2U/6	6		4,200	6,000	9,000	12,000	15,000	18,000	21,000	
XV 2U/9	8,4		6,300	9,000	13,500	18,000	22,500	27,000	31,500	
XV 2U/11	10,8		7,700	11,000	16,500	22,000	27,500	33,000	38,500	
XV 2U/14	14,4		9,800	14,000	21,000	28,000	35,000	42,000	29,000	
XV 2U/17	16,8		11,900	17,000	25,500	34,000	42,500	51,000	59,500	
XV 2U/19	19,2		13,300	19,000	28,500	38,000	47,500	57,000		
XV 2U/22	22,8		15,400	22,000	33,000	44,000	55,000	66,000		
XV 2U/26	26,2		18,200	26,000	39,000	52,000	65,000	78,000		
XV 2U/30	30		21,000	30,000	45,000	60,000	75,000			
XV 2U/34	34,2		23,800	34,000	51,000	68,000	85,000			
XV 2U/40	39,6		28,000	40,000	60,000	80,000				

TYPE	cm3/rev		rpm							
			700	1000	1500	2000	2300	2500		3000
XV 3U/15	14,89	Flow rate l/min	9,90	14,15	21,22	28,29	32,54	35,37	42,44	Flow rate l/min
XV 3U/18	17,37		11,55	16,51	24,76	33,01	37,96	41,26	49,52	
XV 3U/21	21,10		14,03	20,04	30,06	40,08	46,10	50,11	60,13	
XV 3U/27	26,97		17,94	25,62	38,43	51,24	58,93	64,05	76,86	
XV 3U/32	32,27		21,46	30,65	45,98	61,31	70,50	76,63	91,96	
XV 3U/38	38,47		25,58	36,55	54,82	73,09	84,06	91,37		
XV 3U/43	43,44		28,88	41,26	61,89	82,53	94,91	103,16		
XV 3U/47	47,16		31,36	44,80	67,20	89,60	103,04	112,00		
XV 3U/51	50,88		33,84	48,34	72,51	96,67	111,17			
XV 3U/54	54,60		36,31	51,87	77,81	103,75	119,31			
XV 3U/61	60,81		40,44	57,77	86,65	115,54	132,87			
XV 3U/64	64,53		42,91	61,31	91,96	122,61	141,00			
XV 3U/70	70,74		47,04	67,20	100,80	134,40	154,56			
XV 3U/74	74,46		49,52	70,74	106,11	141,47	162,70			
XV 3U/90	86,87		57,77	82,53	123,79	165,05	189,81			

**TORQUES ALLOWED ON SHAFT:**

FORMULA FOR EVALUATING SHAFT		SHAFT [IDENTIFIER] - CODE - DESCRIPTION	T.2 [Nm]
$T.2 \leq \frac{v_i \times \Delta p \times \eta m}{20 \times \pi}$ <p>T.2 = max. torque allowed by shaft [ Nm]</p>	XV-0U	[A] - CI001 - Parallel ø 7 - M 7x1 - key thk sp.2	2
		[B] - CF001 - Milled shank ø 7 - sp. 5	9,2
		[F] - CF005 - Milled shank ø 7 - sp.4,5 L = 9	8
	XV-1U	[A] - CI001 - Parallel ø12 - M10x1 - key thk. 3	25,8
		[B] - CI002 - Parallel ø12.7 - key thk. 3.2 (SAE)	32,8
		[C] - CF001 - Milled shank ø10 - thk.5 ("BH" Standard German)	13,8
		[D] - CF002 - Milled shank ø10 - thk.5	13,8
		[E] - CF003 - Milled shank ø11 - thk.6.63 (SAE)	25,8
		[F] - CO001 - Tapered 1:8 - ø10 - M7x1 - key thk.2.4	43
		[G] - CO002 - Tapered 1:8 - ø14 - M10x1 - key thk.3	119,8
		[ I ] - CO004 - Tapered 1:8 - ø12.7 - 5/16" 24UNF-2A - key thk.3.2 (SAE)	90,4
		[J] - SCF04 - Splined ø11.7 - z=6, H=17.5, m=1.6, DIN 5482 12x9	22,6
		[K] - SCF05 - Splined ø12.344, z=9, H=19, SAE J498 9T 20/40DB	32,2
		[L] - SCF02 - Splined ø11.9, z=15, H=17.5, m=0.75	42,8
		[O] - CO002+HK - Tapered 1:8 - ø14 - M10x1, HK 14-12, key thk.3	119,8
		[P] - CI001+HK - Parallel ø12 - M10x1 with bearing HK 14-12 - key thk.3	25,8
		[Q] - SCF01 - Splined ø11.9, z=15, H=9, m=0.75	42,8
	[R] - SCF03 - Splined ø11.9, z=15, H=9, m=0.75	42,8	
	XV-2U	[A] - CI001 - Parallel ø15 - M6x1 - key thk.4	44.1
		[B] - CI002 - Parallel ø15.875 - 1/4"28-UNF key thk.4 (SAE A)	67.5
		[C] - CF001 - Miled shank ø15 - thk.8 ("BH" Standard German)	60.5
		[E] - CO001 - Tapered 1:8 - ø17,4 - M12x1,5 - key thk.4	233.2
		[F] - CO002 - Tapered 1:5 - ø17,4 - M12x1,5 - key thk.3	233.2
		[G] - SCF02 - Splined ø16,5 - z=9, H=13, m=1.6 DIN 5482 17x14	86.1
		[H] - SCF03 - Splined ø16.5 - z=9, H=18,8, m=1,6 DIN 5482 17x14	86.1
		[ I ] - SCF04 - Splined ø15.456 z=9, H=22.5, SAE J498 9T 16/32DP	67.1
		[K] - SCF05 - Splined ø16.5 z=9 H=8,1 m=1.6 DIN 5482 17x14	86.2
		[L] - SCF01 - Splined ø16.5 z=9 H=9,2 m=1.6 DIN 5482 17x14	86.2
		[M] - CO001 - Tapered 1:8 - ø17,4 - M12x1,5 - key thk.3,2	233.2
	XV-3U	[A] - COP01 - Tapered 1:8 - ø22 - M14x1.5 - key thk.4	482
[B] - CI001 - Parallel ø20 - M8 - key thk.5		181	
[C] - SCF03 - Splined ø21.5, z=13, H=25, m=1,6		223	
[H] - CI004 - Parallel ø22.225- 1/4"28-UNF key thk.6.35 (SAE B)		180	
[ I ] - SCF04 - Splined o ø21.8059, z=13, H=25, SAE J498 9T 16/32DP		264	

**NOTES:**

For assemblies with a coupling, you should choose one as balanced as possible in order to reduce the vibrations and dynamic stresses to which the shaft may be subject.

**Always make sure that the torque is less than or equal to the admissible torque of the shaft.** Do not apply a direct axial or radial load on the shaft; if necessary, use suitable supports.

Always use well-filtered oils containing no water or other emulsifying substance.

Never run the pump with oil and air solutions.

For motors with outlets on the flange, it is recommended not to exceed a flow rate of

4 l/min	XV-0U
20 l/min.	XV-1U
35 l/min	XV-2U

## Useful calculation formulas

SYMBOL, UNIT OF MEASUREMENT, DESCRIPTION		
qv	l/min	Flow rate
vi	cm <sup>3</sup> /rev.	Displacement (volume of oil displaced per complete revolution of the shaft)
n	rpm	Shaft rotation speed
p1	bar	inlet pressure
p2	bar	outlet pressure
Δp	bar	Δp=p2 - p1 difference between outlet (OUT) and inlet (IN) pressure
Ph	kW	Hydraulic power delivered
Pm	kW	Mechanical power absorbed
T	Nm	Torque absorbed by shaft
ηv	-	0.91 – 0.96 volumetric efficiency (volumetric ratio between operation under load and loadless operation)
ηm	-	0.85 – 0.90 mechanical efficiency
ηt	-	ηt = ηv x ηm total efficiency

Basic Formulas	Derived Formulas	
$qv = \frac{vi \times n}{1000} \times \eta v$	$vi = \frac{qv \times 1000}{n \times \eta v}$	$n = \frac{qv \times 1000}{vi \times \eta v}$
$T = \frac{vi \times \Delta p \times \eta m}{20 \times \pi}$	$vi = \frac{T \times 20 \times \pi}{\Delta p \times \eta m}$	$\Delta p = \frac{T \times 20 \times \pi}{vi \times \eta m}$
$Ph = \frac{qv \times \Delta p}{600}$	$qv = \frac{Ph \times 600}{\Delta p}$	$\Delta p = \frac{Ph \times 600}{qv}$
$Pm = \frac{vi \times \Delta p \times n \times \eta m}{600000}$	$vi = \frac{Pm \times 600000}{\Delta p \times n \times \eta m}$	$\Delta p = \frac{600000 \times \eta m}{vi \times n \times \eta m}$

## Constructive features

PART	MATERIAL	MECHANICAL FEATURES
<b>PUMP BODY</b>	Extruded alloy Series 7000, heat treated and anodised	Rp = 345 N/mm <sup>2</sup> (Yield strength) Rm = 382 N/mm <sup>2</sup> (Breaking strength)
<b>FLANGE AND COVER</b>	Die-cast aluminium alloy with excellent mechanical features, heat treated and anodised	Rp = 310÷350 N/mm <sup>2</sup> (Yield strength) Rm = 350÷400 N/mm <sup>2</sup> (Breaking strength)
<b>GEAR BUSH BEARINGS</b>	Special heat-treated tin alloy with excellent mechanical features and high anti-friction capacity. Self-lubricating bushes DU	Rp = 350 N/mm <sup>2</sup> (Yield strength) Rm = 390 N/mm <sup>2</sup> (Breaking strength)
<b>GEARS</b>	Steel UNI 7846	Rs = 980 N/mm <sup>2</sup> (Yield strength) Rm = 1270÷1570 N/mm <sup>2</sup> (Breaking strength)
<b>SEALS</b>	A 727 Standard Acrylonitrile F 975 Viton FKM	70 Shore, thermal resistance 120°C 80 Shore, thermal resistance 200°C
<b>BACK-UP RINGS</b>	Virgin PTFE Tecnil Q3	

**XV-0U CHARACTERISTIC FLOW RATE CURVES**

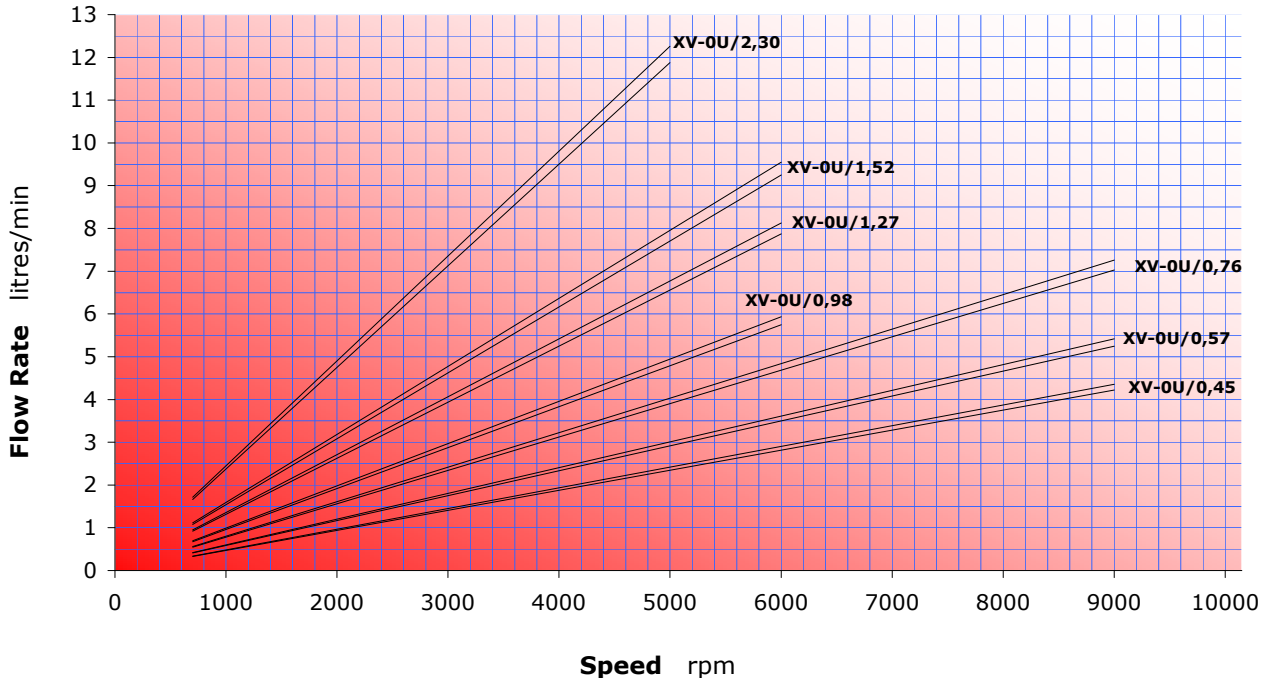

**XV-0U MOTOR TORQUE**

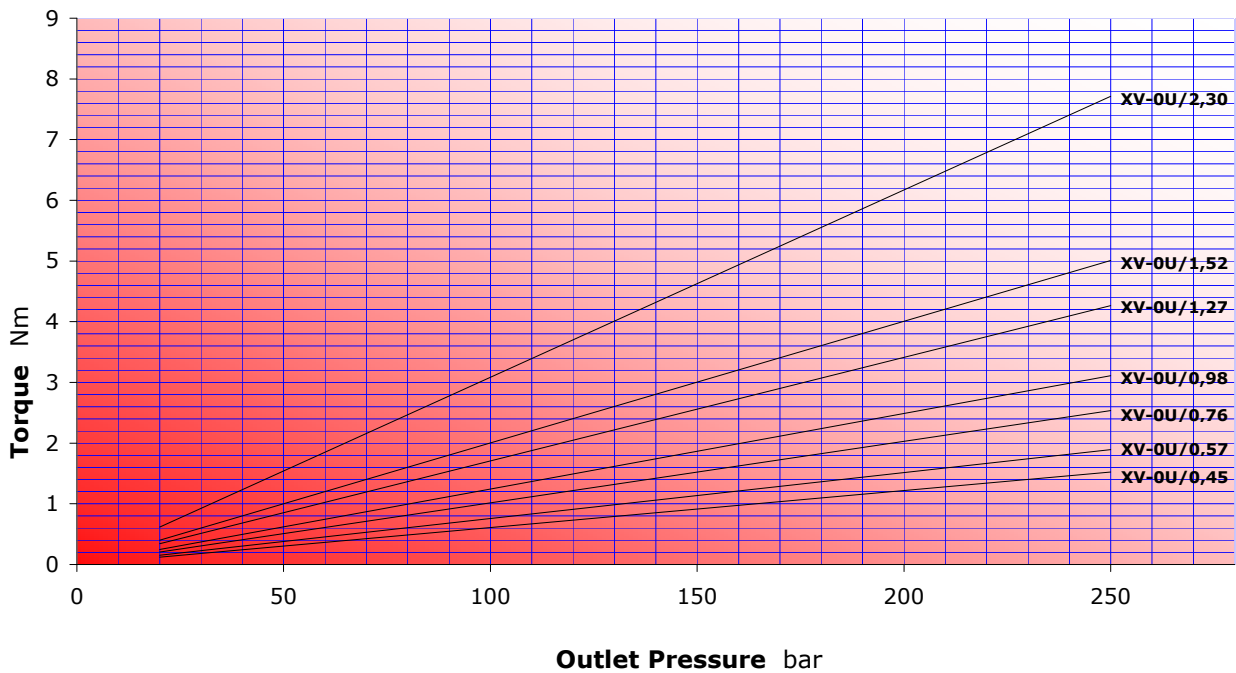

**XV-1U CHARACTERISTIC FLOW RATE CURVES**

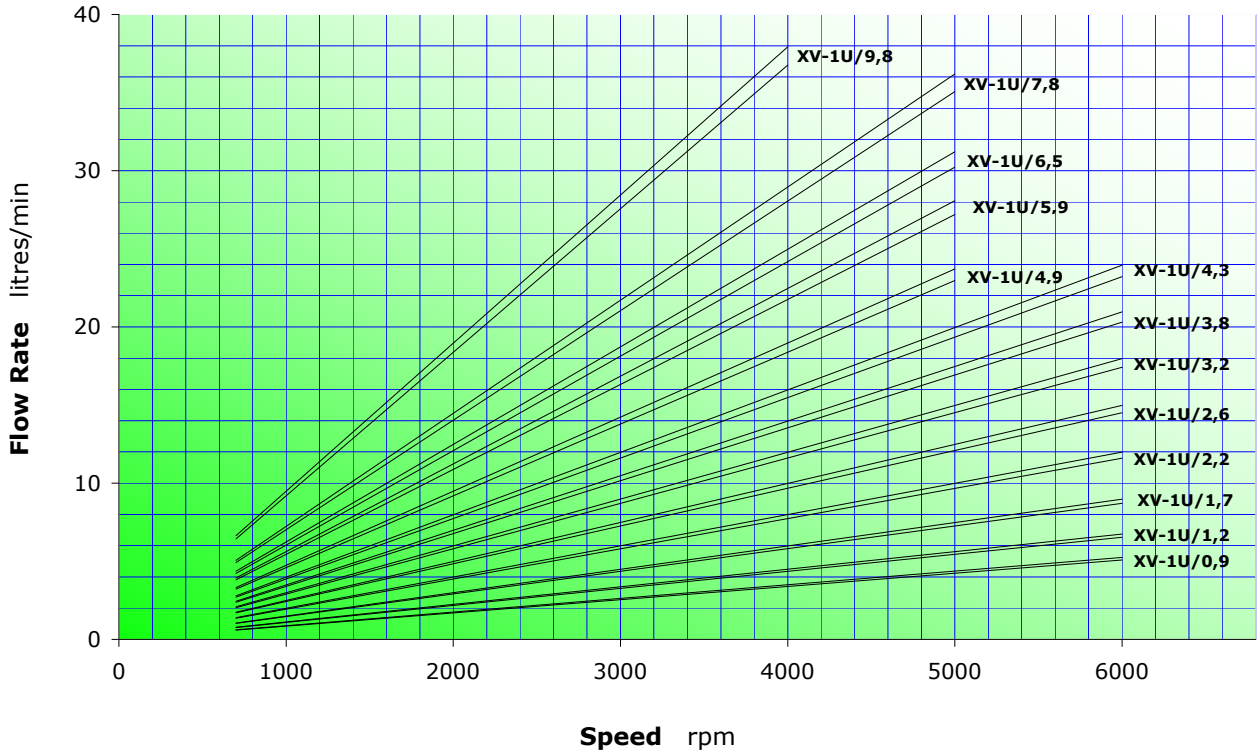

**XV-1U MOTOR TORQUE**

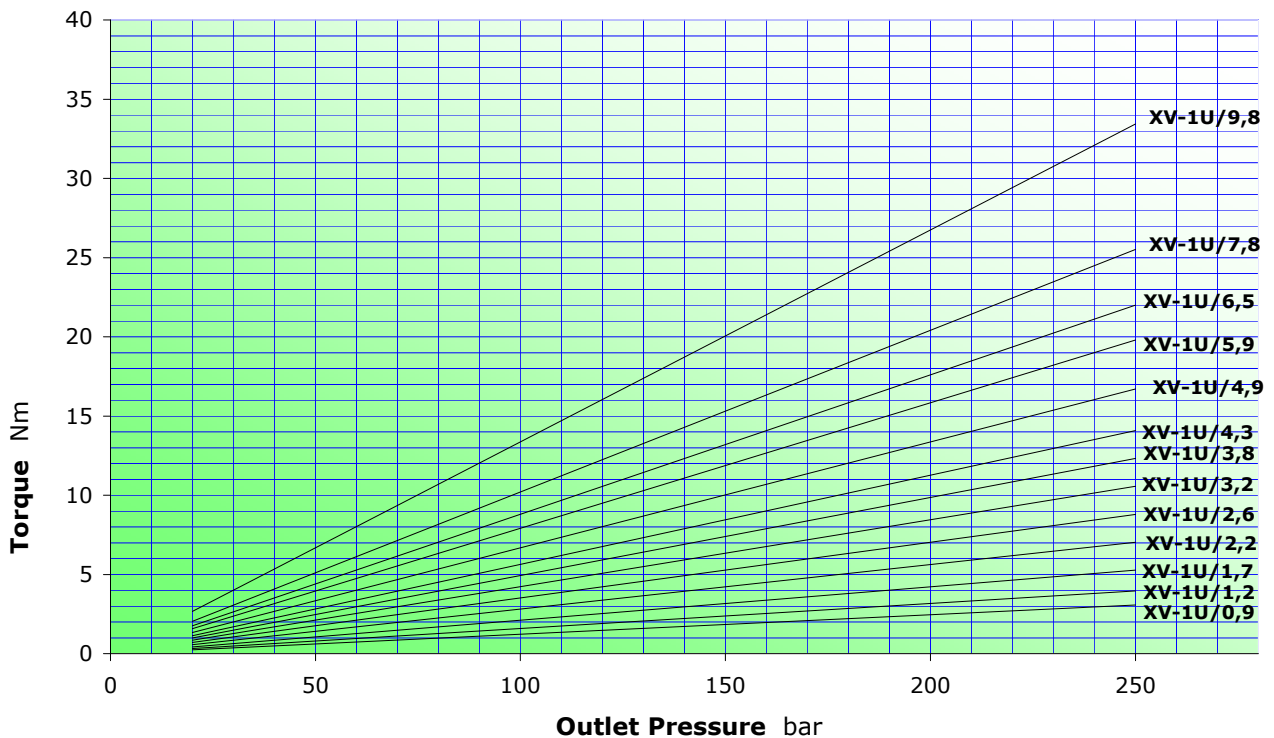

**XV-2U CHARACTERISTIC FLOW RATE CURVES**

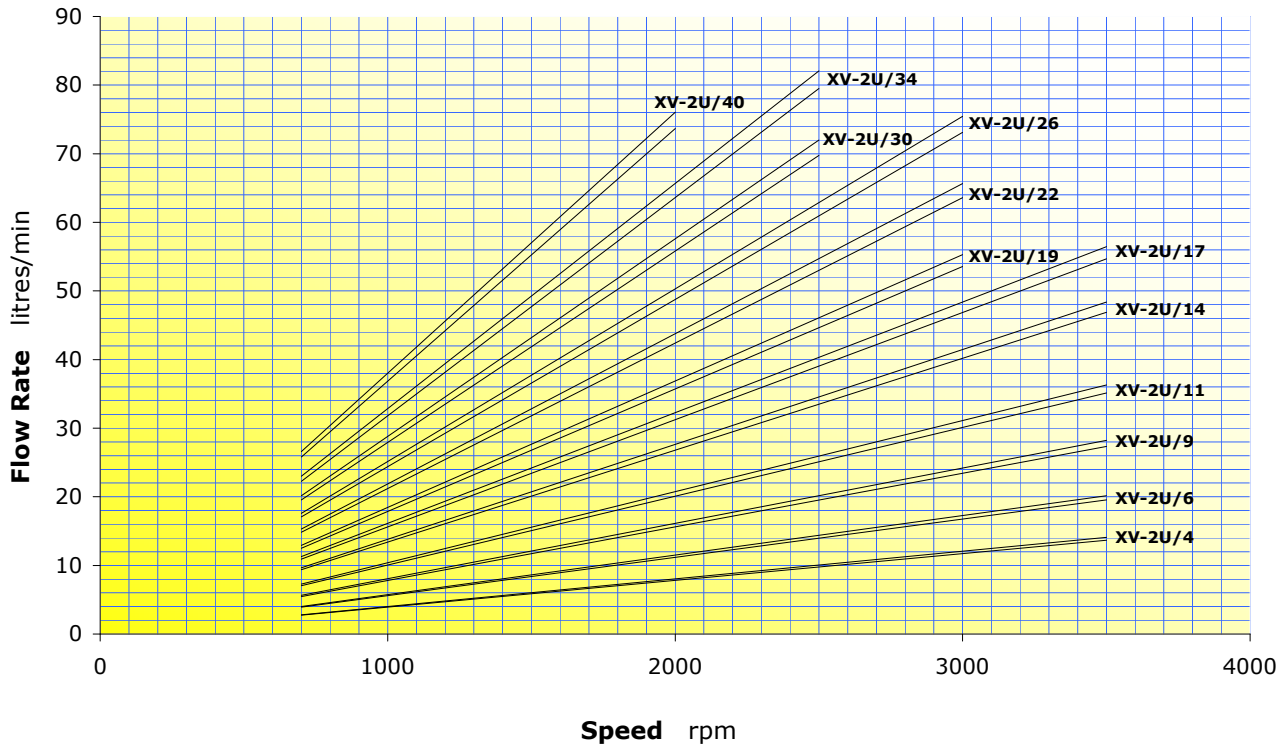

**XV-2U MOTOR TORQUE**

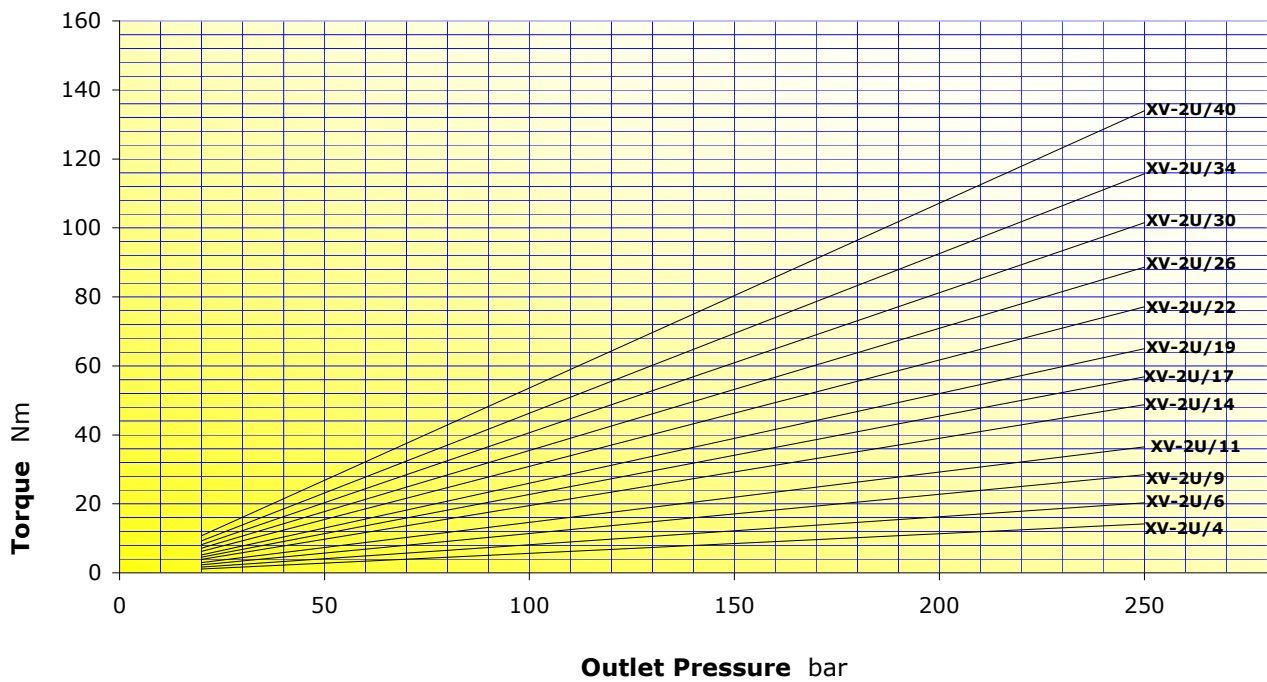

**XV-3U CHARACTERISTIC FLOW RATE CURVES**

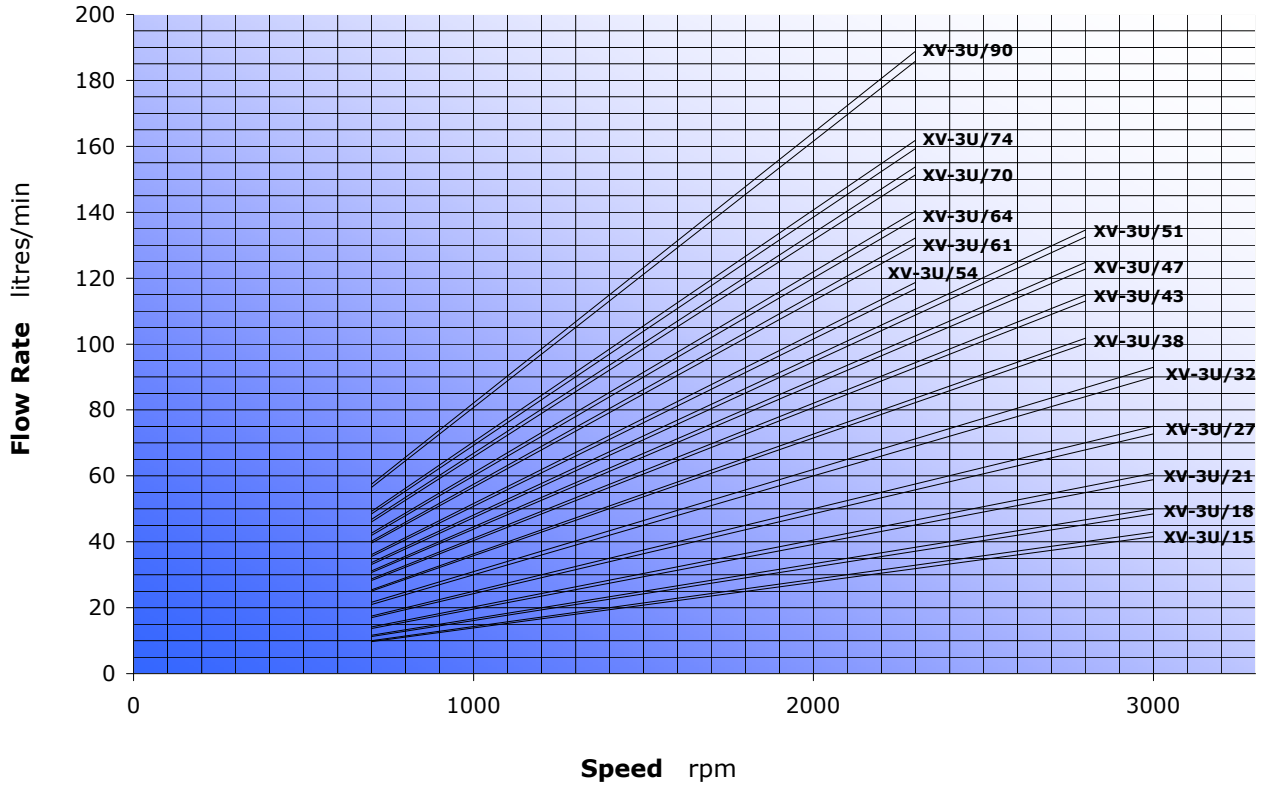

**XV-3U MOTOR TORQUE**

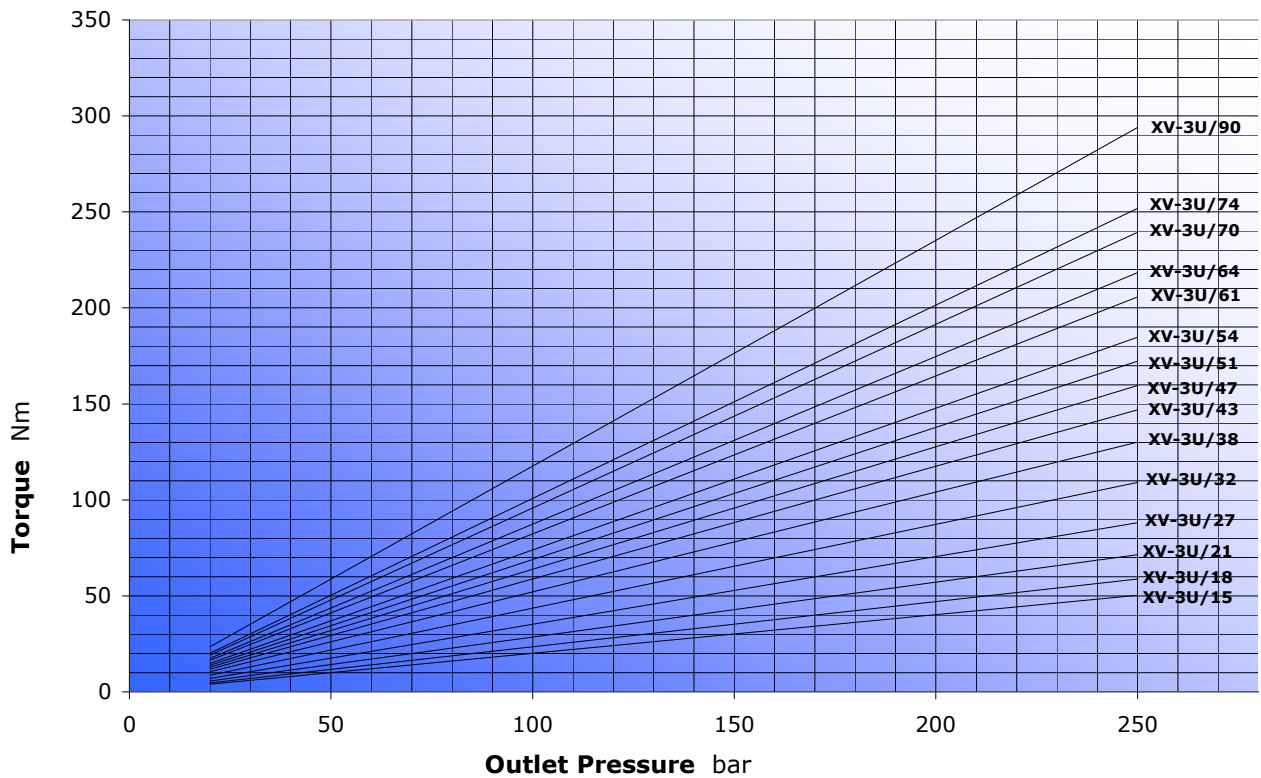

**XV0-U** with Flange  $\varnothing 22$  Std, BH-HY (ref. from XU- 001 to XU-017)

When changing the direction of rotation of the XV-0U motor, it is not necessary to change the flange, as the same one is used.

When disassembling and reassembling the motor, take special care to ensure that seals and back-up rings do not come out of place and that no foreign bodies, such as shavings or dirt in general, get inside the motor.

<b>Flange <math>\varnothing 22</math></b> (ref. from XU- 001 to: XU- 017)					
<p>Remove the key, nut and washer from the shaft. Loosen and remove the fastening screws.</p>	<p>Take off the flange.</p>	<p>Take out the gears and upper bush.</p> <p><b>Warning!!</b> The bush <b>must never</b> be turned.</p>	<p>Invert the positions of the driven and driving shafts.</p> <p><b>Warning!</b> The body and cover must not be turned. Use the marking on the body as your reference.</p>	<p>Fit the previously removed flange back in place taking care to clean the body-base contact surfaces.</p>	<p>Insert the screws back in place and tighten the nuts with a torque of 11.7 Nm to 13.7 Nm. Check that the shaft turns on completing the operation.</p>
<p>Note: with this rotation change system, the <b>inlets</b> and <b>outlets</b> remain unchanged.</p>					

## XV1-U with Flange $\varnothing 25.4$ (ref. XU- 101)

When changing the direction of rotation of the XV-1U motor, it is not necessary to change the flange, as the same one is used.

When disassembling and reassembling the motor, take special care to ensure that seals and back-up rings do not come out of place and that no foreign bodies, such as shavings or dirt in general, get inside the motor.

<b>Flange <math>\varnothing 25,4</math> (ref. XU- 101)</b>					
<p>Remove the key, nut and washer from the shaft. Loosen and remove the fastening screws.</p>	<p>Take off the flange.</p>	<p>Take out the gears and upper bush.</p> <p><b>Warning!!</b> The bush <b>must never</b> be turned.</p>	<p>Invert the positions of the driven and driving shafts.</p> <p><b>Warning!</b> The body and cover must not be turned. Use the marking on the body as your reference.</p>	<p>Fit the previously removed flange back in place taking care to clean the body-base contact surfaces.</p>	<p>Replace the screws and tighten the nuts with a torque of 24.5 Nm to 29.4 Nm.</p> <p>Check that the shaft turns on completing the operation.</p>
<p>Note: with this rotation change system, the <b>inlets</b> and <b>outlets</b> remain unchanged.</p>					

## XV1-U with Flange $\varnothing 30$ (ref. XU- 113)

When changing the direction of rotation of the XV-1P motor, it is not necessary to change the flange, as the same one is used.

When disassembling and reassembling the motor, take special care to ensure that seals and back-up rings do not come out of place and that no foreign bodies, such as shavings or dirt in general, get inside the motor.

<b>Flange <math>\varnothing 30</math></b> (ref. XU- 113)					
Remove the key, nut and washer from the shaft. Loosen and remove the fastening screws.	Take off the flange.	Take out the gears and upper bush.  Warning!! The bush <b>must</b> be turned.	Invert the positions of the driven and driving shafts. Warning! The body and cover must not be turned. Use the marking on the body as your reference.	Fit the previously removed flange back in place taking care to clean the body-base contact surfaces.	Replace the screws and tighten the nuts with a torque of 24.5 Nm to 29.4 Nm. Check that the shaft turns on completing the operation.
Note: with this rotation change system, the <b>inlets</b> and <b>outlets</b> remain unchanged.					

**XV1-U** with Flange ø32 BH-HY (ref. from XU- 119 to: XU- 140)

When changing the direction of rotation of the XV-1P motor, it is not necessary to change the flange, as the same one is used.

When disassembling and reassembling the motor, take special care to ensure that seals and back-up rings do not come out of place and that no foreign bodies, such as shavings or dirt in general, get inside the motor.

FLANGE ø32 BH-HY (ref. da XU- 119 a: XU- 140)					
Loosen and remove the fastening screws.	Take off the flange.	Take out the gears and upper bush.  Warning!! The bush <b>must never</b> be turned.	Invert the positions of the driven and driving shafts.  Warning! The body and cover must not be turned. Use the marking on the body as your reference.	Fit the previously removed flange back in place taking care to clean the body-base contact surfaces.	Replace the screws and tighten the nuts with a torque of 24.5 Nm to 29.4 Nm.  Check that the shaft turns on completing the operation.
Note: with this rotation change system, the <b>inlets</b> and <b>outlets</b> remain unchanged.					

## XV1-U with Flange ø50.8 SAE-AA (ref. XU- 168 )

When changing the direction of rotation of the XV-1P motor, it is not necessary to change the flange, as the same one is used.

When disassembling and reassembling the motor, take special care to ensure that seals and back-up rings do not come out of place and that no foreign bodies, such as shavings or dirt in general, get inside the motor.

FLANGE ø50.8 SAE-AA (ref. XU- 168)					
Remove the key from the shaft. Loosen and remove the fastening screws.	Take off the flange.	Take out the gears and upper bush.  Warning!! The bush <b>must</b> be turned.	Invert the positions of the driven and driving shafts. Warning! The body and cover must not be turned. Use the marking on the body as your reference.	Fit the previously removed flange back in place taking care to clean the body-base contact surfaces.	Replace the screws back in place and tighten the nuts with a torque of 24.5 Nm to 29.4 Nm. Check that the shaft turns on completing the operation.
Note: with this rotation change system, the <b>inlets</b> and <b>outlets</b> remain unchanged.					

## XV2-U with Flange $\varnothing 36,5$ (ref. XU- 201)

When changing the direction of rotation of the XV-2P motor, it is not necessary to change the flange, as the same one is used.

When disassembling and reassembling the motor, take special care to ensure that seals and back-up rings do not come out of place and that no foreign bodies, such as shavings or dirt in general, get inside the motor.

<b>FLANGE <math>\varnothing 36,5</math></b> (ref. XU- 201)					
<p>Remove the key, nut and washer from the shaft. Loosen and remove the fastening screws.</p>	<p>Take off the flange.</p>	<p>Take out the gears and upper bush.</p> <p>Warning!! The bush <b>must never</b> be turned.</p>	<p>Invert the positions of the driven and driving shafts.</p> <p>Warning! The body and cover must not be turned. Use the marking on the body as your reference.</p>	<p>Fit the previously removed flange back in place taking care to clean the body-base contact surfaces.</p>	<p>Replace the screws and tighten the nuts with a torque of 54 Nm to 58.9 Nm. Check that the shaft turns on completing the operation.</p>
<p>Note: with this rotation change system, the <b>inlets</b> and <b>outlets</b> remain unchanged.</p>					

### XV2-U with Flange $\varnothing 50$ BH-HY (ref. da XU- 210 a: XU- 213)

When changing the direction of rotation of the XV-2P motor, it is not necessary to change the flange, as the same one is used.

When disassembling and reassembling the motor, take special care to ensure that seals and back-up rings do not come out of place and that no foreign bodies, such as shavings or dirt in general, get inside the motor.

FLANGE $\varnothing 50$ BH-HY (ref. da XU- 210 a: XU- 213)					
<p>Remove the key, nut and washer from the shaft. Loosen and remove the fastening screws.</p>	<p>Take off the flange.</p>	<p>Take out the gears and upper bush.</p> <p>Warning!! The bush <b>must never</b> be turned.</p>	<p>Invert the positions of the driven and driving shafts.</p> <p>Warning! The body and cover must not be turned. Use the marking on the body as your reference.</p>	<p>Fit the previously removed flange back in place taking care to clean the body-base contact surfaces.</p>	<p>Replace the screws and tighten the nuts with a torque of 54 Nm to 58.9Nm. Check that the shaft turns on completing the operation.</p>
<p>Note: with this rotation change system, the <b>inlets</b> and <b>outlets</b> remain unchanged.</p>					

## XV2-U with Flange ø52 BH (ref. XU- 216 )

When changing the direction of rotation of the XV-2P motor, it is not necessary to change the flange, as the same one is used.

When disassembling and reassembling the motor, take special care to ensure that seals and back-up rings do not come out of place and that no foreign bodies, such as shavings or dirt in general, get inside the motor.

FLANGE ø52 BH (ref.XU- 216)					
<p>Loosen and remove the fastening screws.</p>	<p>Take off the flange.</p>	<p>Take out the gears and upper bush.</p> <p>Warning!! The bush must never be turned.</p>	<p>Invert the positions of the driven and driving shafts.</p> <p>Warning! The body and cover must not be turned. Use the marking on the body as your reference.</p>	<p>Fit the previously removed flange back in place taking care to clean the body-base contact surfaces.</p>	<p>Replace the screws and tighten the nuts with a torque of 54 Nm to 58.9Nm. Check that the shaft turns on completing the operation.</p>
<p>Note: with this rotation change system, the <b>inlets</b> and <b>outlets</b> remain unchanged.</p>					

## XV2-U with Flange ø80 (ref. XU- 217 )

When changing the direction of rotation of the XV-2P motor, it is not necessary to change the flange, as the same one is used.

When disassembling and reassembling the motor, take special care to ensure that seals and back-up rings do not come out of place and that no foreign bodies, such as shavings or dirt in general, get inside the motor.

FLANGE ø80 (ref.XU- 217 )					
<p>Remove the key, nut and washer from the shaft. Loosen and remove the fastening screws.</p>	<p>Take off the flange.</p>	<p>Take out the gears and upper bush.</p> <p>Warning!! The bush <b>must never</b> be turned.</p>	<p>Invert the positions of the driven and driving shafts.</p> <p>Warning! The body and cover must not be turned. Use the marking on the body as your reference.</p>	<p>Fit the previously removed flange back in place taking care to clean the body-base contact surfaces.</p>	<p>Replace the screws and tighten the nuts with a torque of 54 Nm to 58.9 Nm. Check that the shaft turns on completing the operation.</p>
<p>Note: with this rotation change system, the <b>inlets</b> and <b>outlets</b> remain unchanged.</p>					

**XV2-U** with Flange  $\varnothing 82,5$  SAE-A (ref. da XU- 219 a: XU- 224)

When changing the direction of rotation of the XV-2P motor, it is not necessary to change the flange, as the same one is used.

When disassembling and reassembling the motor, take special care to ensure that seals and back-up rings do not come out of place and that no foreign bodies, such as shavings or dirt in general, get inside the motor.

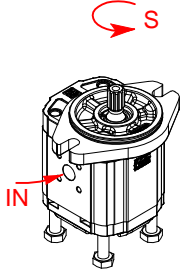
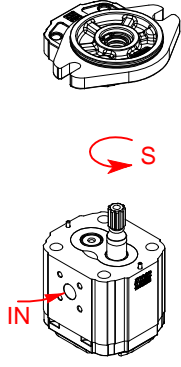
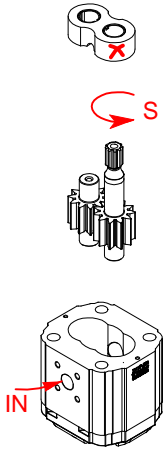
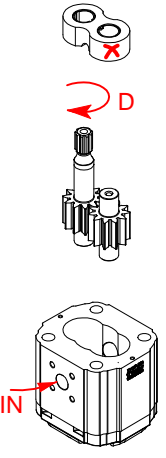
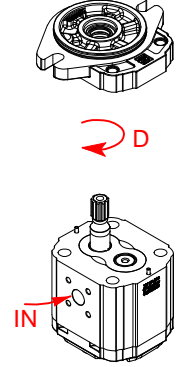
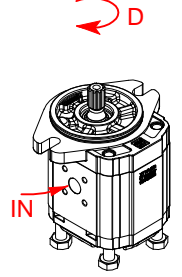
<b>FLANGE <math>\varnothing 82,5</math> SAE-A (ref. XU- 219)</b>					
					
Loosen and remove the fastening screws.	and Take off the flange.	Take out the gears and upper bush.  Warning!! The bush <b>must never</b> be turned.	Invert the positions of the driven and driving shafts. Warning! The body and cover must not be turned. Use the marking on the body as your reference.	Fit the previously removed flange back in place taking care to clean the body-base contact surfaces.	Replace the screws and tighten the nuts with a torque of 54 Nm to 58.9Nm. Check that the shaft turns on completing the operation.
<p>Note: with this rotation change system, the <b>inlets</b> and <b>outlets</b> remain unchanged.</p>					

## XV3-U with Flange $\varnothing 50,8$ (ref. da XU- 301 a: XU- 302)

When changing the direction of rotation of the XV-3P motor, it is not necessary to change the flange, as the same one is used.

When disassembling and reassembling the motor, take special care to ensure that seals and back-up rings do not come out of place and that no foreign bodies, such as shavings or dirt in general, get inside the motor.

<b>Flange <math>\varnothing 50,8</math></b>					
Remove the key, nut and washer from the shaft. Loosen and remove the fastening screws.	Take off the flange.	Take out the gears and upper bush.  Warning!! The bush <b>must never</b> be turned.	Invert the positions of the driven and driving shafts. Warning! The body and cover must not be turned. Use the marking on the body as your reference.	Fit the previously removed flange back in place taking care to clean the body-base contact surfaces.	Replace the screws and tighten the nuts with a torque of 60 Nm to 65 Nm. Check that the shaft turns on completing the operation.
Note: with this rotation change system, the <b>inlets</b> and <b>outlets</b> remain unchanged.					

## XV3-U with Flange $\varnothing 101,6$ – SAE- B (ref. da XU- 331 a: XU- 332)

When changing the direction of rotation of the XV-3P motor, it is not necessary to change the flange, as the same one is used.

When disassembling and reassembling the motor, take special care to ensure that seals and back-up rings do not come out of place and that no foreign bodies, such as shavings or dirt in general, get inside the motor.

<b>Flange <math>\varnothing 101,6</math>-SAE -B</b>					
Loosen and remove the fastening screws.	Take off the flange.	Take out the gears and upper bush.  Warning!! The bush <b>must never</b> be turned.	Invert the positions of the driven and driving shafts. Warning! The body and cover must not be turned. Use the marking on the body as your reference.	Fit the previously removed flange back in place taking care to clean the body-base contact surfaces.	Replace the screws and tighten the nuts with a torque of 60 Nm to 65 Nm. Check that the shaft turns on completing the operation.
<p>Note: with this rotation change system, the <b>inlets</b> and <b>outlets</b> remain unchanged.</p>					

# unidirectional motor - series XV

**XV-OU**

**STANDARD MOTOR**  
**Ø22 FLANGE - PARALLEL SHAFT**

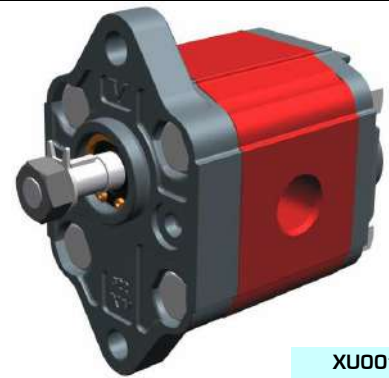

**XU001**

**X 0 U 06 02 A B B A**

Series	X	series XV
Group	0	group 0
Category	U	unidirectional motor
Displacement	06	0.76
Flange	02	Ø22 right rotation
Shaft	A	CI001 - Parallel ø7 - M7x1 - key thk. 2
Body	IN	inlet - 1/4" GAS
	OUT	outlet - 1/4" GAS
Cover	A	standard

Technical data table						
TYPE	Displacement cm3/rev	Max. Pressure		CODE		
		P1 bar	P3 bar	Left rotation	Right rotation	
XV-OU/0.45	0,45	220	280	X 0 U 04 01 A B B A	X 0 U 04 02 A B B A	
XV-OU/0.57	0,56	220	280	X 0 U 05 01 A B B A	X 0 U 05 02 A B B A	
XV-OU/0.76	0,75	200	260	X 0 U 06 01 A B B A	X 0 U 06 02 A B B A	
XV-OU/0.98	0,92	200	260	X 0 U 07 01 A B B A	X 0 U 07 02 A B B A	
XV-OU/1.27	1,26	200	260	X 0 U 09 01 A B B A	X 0 U 09 02 A B B A	
XV-OU/1.52	1,48	200	260	X 0 U 11 01 A B B A	X 0 U 11 02 A B B A	
XV-OU/2.30	2,28	160	190	X 0 U 13 01 A B B A	X 0 U 13 02 A B B A	

P1) Max. working pressure - P3) Max. peak pressure

For heavy-duty applications, it is recommended to check the admissible torque of the shaft

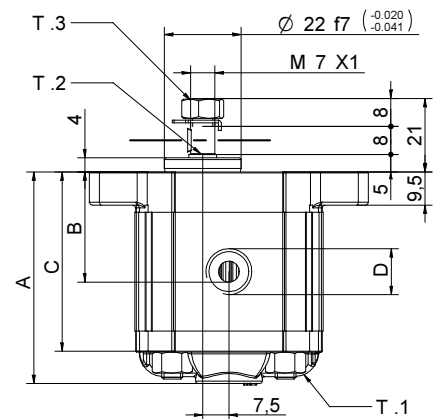
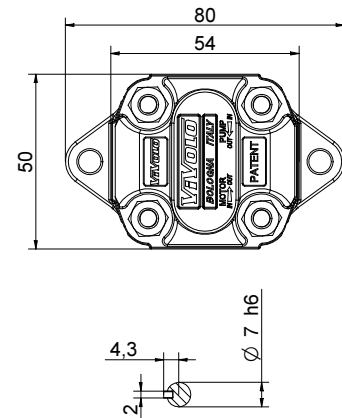

Dimensions table						
TYPE	Weight kg	A	B	C	D	D
		mm	mm	mm	IN	OUT
XV-OU/0.45	0,420	58,0	27,3	49,0	1/4" BSPP	1/4" BSPP
XV-OU/0.57	0,430	59,0	27,8	50,0	1/4" BSPP	1/4" BSPP
XV-OU/0.76	0,440	60,5	28,5	51,5	1/4" BSPP	1/4" BSPP
XV-OU/0.98	0,460	62,0	29,3	53,0	1/4" BSPP	1/4" BSPP
XV-OU/1.27	0,480	64,5	30,5	55,5	1/4" BSPP	1/4" BSPP
XV-OU/1.52	0,500	66,5	31,5	57,5	1/4" BSPP	1/4" BSPP
XV-OU/2.30	0,560	72,5	34,5	63,5	1/4" BSPP	1/4" BSPP

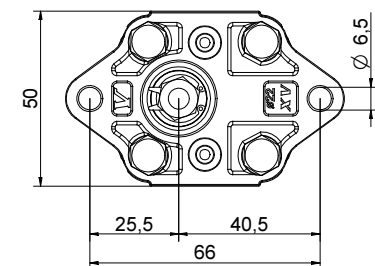

07/12/04 XOP0602ABBA.dft

T.1 = 11.7÷13.7 [Nm] - screw tightening torque M6

T.3 = 11.5 [Nm] - torque wrench setting 11

T.2 = 2.1 [Nm] - admissible shaft torque (N.B. When choosing a shaft, always check the admissible torque).

# Table of variations

**XV-OU**

## Standard ø22 FLANGE

Standard ø22 FLANGE				Shaft				Cover			
Left rotation		Right rotation						Left rotation		Right rotation	
	01		02	CI001 - Parallel T.2 = 2.1 [Nm]	A	CF001 - Milled shank T.2 = 9.2 [Nm]	B				A
	03		04	CF005 - Milled shank T.2 = 8.4 [Nm]	F	CO001 - Tapered T.2 = 21.9 [Nm]	E				B
	05		06								C
	07		08								D

Displacement	
TYPE	CODE
XV-OU/0.45	04
XV-OU/0.57	05
XV-OU/0.76	06
XV-OU/0.98	07
XV-OU/1.27	09
XV-OU/1.52	11
XV-OU/2.30	13

Standard bodies				
Displacement cm <sup>3</sup> /rev	Standard threads			
	0.17	B - B	Z - B	Z - Z
0.25	B - B	Z - B	Z - Z	
0.45	B - B	Z - B	Z - Z	
0.57	B - B	Z - B	Z - Z	
0.76	B - B	Z - B	Z - Z	
0.98	B - B	Z - B	Z - Z	
1.27	B - B	Z - B	Z - Z	
1.52	B - B	Z - B	Z - Z	
2.30	B - B	Z - B	Z - Z	

Table showing standard flange and thread combinations available in stock

			N
Internal drainage			
			O
External drainage			

Body (threads/flanges)													
	A		B		C		D		E		F		G
	H		I	Closed Body		Z							

# unidirectional motor - series XV

**XV-OU**

**BH TYPE MOTOR**  
**ø22 BODY-SHAPED FLANGE - MILLED SHANK**

**X 0 U 06 12 B B B A**

Series	X	series XV
Group	0	group 0
Category	U	unidirectional motor
Displacement	06	0.76
Flange	12	Ø22 BH right rotation
Shaft	B	CF001 - Milled shank ø7 - thk.5
Body	IN	inlet - 1/4" GAS
	OUT	outlet - 1/4" GAS
Cover	A	standard



**XU012**

**Technical data table**

TYPE	Displacement cm3/rev	Max. Pressure		CODE	
		P1 bar	P3 bar	Left rotation	Right rotation
XV-OU/0.45	0,45	220	280	X 0 U 04 11 B B B A	X 0 U 04 12 B B B A
XV-OU/0.57	0,56	220	280	X 0 U 05 11 B B B A	X 0 U 05 12 B B B A
XV-OU/0.76	0,75	200	260	X 0 U 06 11 B B B A	X 0 U 06 12 B B B A
XV-OU/0.98	0,92	200	260	X 0 U 07 11 B B B A	X 0 U 07 12 B B B A
XV-OU/1.27	1,26	200	260	X 0 U 09 11 B B B A	X 0 U 09 12 B B B A
XV-OU/1.52	1,48	200	260	X 0 U 11 11 B B B A	X 0 U 11 12 B B B A
XV-OU/2.30	2,28	160	190	X 0 U 13 11 B B B A	X 0 U 13 12 B B B A

P1) Max. working pressure - P3) Max. peak pressure

For heavy-duty applications, it is recommended to check the admissible torque of the shaft

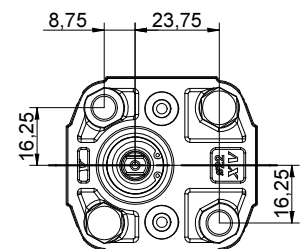
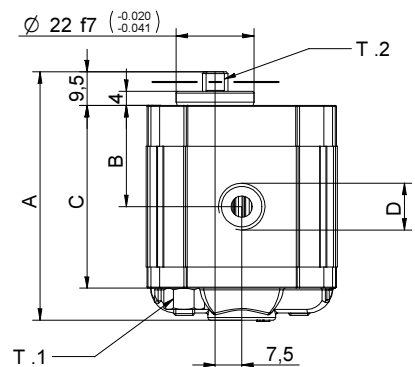
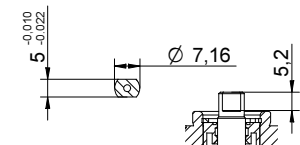
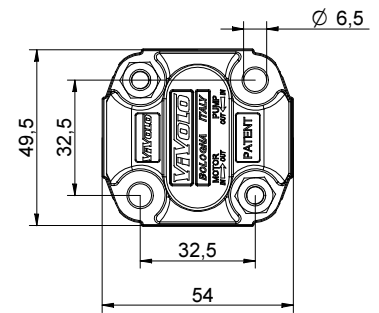

07/12/04 X0P061288BA.dft

**Dimensions table**

TYPE	Weight kg	A	B	C	D	D
		mm	mm	mm	IN	OUT
XV-OU/0.45	0,420	58,0	27,3	49,0	1/4" BSPP	1/4" BSPP
XV-OU/0.57	0,430	59,0	27,8	50,0	1/4" BSPP	1/4" BSPP
XV-OU/0.76	0,440	60,5	28,5	51,5	1/4" BSPP	1/4" BSPP
XV-OU/0.98	0,460	62,0	29,3	53,0	1/4" BSPP	1/4" BSPP
XV-OU/1.27	0,480	64,5	30,5	55,5	1/4" BSPP	1/4" BSPP
XV-OU/1.52	0,500	66,5	31,5	57,5	1/4" BSPP	1/4" BSPP
XV-OU/2.30	0,560	72,5	34,5	63,5	1/4" BSPP	1/4" BSPP

T.1 = 11.7÷13.7 [Nm] - screw tightening torque M6

T.2 = 9.2 [Nm] - admissible shaft torque (N.B. When choosing a shaft, always check the admissible torque).

# Table of variations

**XV-OU**

## ø22 "BH" Body-Shaped FLANGE

ø22 "BH" Body-Shaped FLANGE				Shaft				Cover			
Left rotation		Right rotation						Left rotation		Right rotation	
	11		12	CI001 - Parallel T.2 = 2.1 [Nm]	A	CF001 - Milled shank T.2 = 9.2 [Nm]	B				A
	13		14	CF005 - Milled shank T.2 = 8.4 [Nm]	F	CO001 - Tapered T.2 = 21.9 [Nm]	E				B
	15		16								C
	17		18								D

Displacement	
TYPE	CODE
XV-OU/0.45	04
XV-OU/0.57	05
XV-OU/0.76	06
XV-OU/0.98	07
XV-OU/1.27	09
XV-OU/1.52	11
XV-OU/2.30	13

Standard bodies				
Displacement cm <sup>3</sup> /rev	Standard threads			
	0.17	B - B	Z - B	Z - Z
0.25	B - B	Z - B	Z - Z	
0.45	B - B	Z - B	Z - Z	
0.57	B - B	Z - B	Z - Z	
0.76	B - B	Z - B	Z - Z	
0.98	B - B	Z - B	Z - Z	
1.27	B - B	Z - B	Z - Z	
1.52	B - B	Z - B	Z - Z	
2.30	B - B	Z - B	Z - Z	

Table showing standard flange and thread combinations available in stock

			N
Internal drainage			
			O
External drainage			

Body (threads/flanges)													
	A		B		C		D		E		F		G
	H		I	Closed Body		Z							

# unidirectional motor - series XV

**XV-OU**

**HY TYPE MOTOR**  
**Ø22 BODY-SHAPED FLANGE - MILLED SHANK**

**X 0 U 06 22 B B B A**

Series	X	series XV
Group	0	group 0
Category	U	unidirectional motor
Displacement	06	0.76
Flange	22	Ø22 HY right rotation
Shaft	B	CF001 - Milled shank ø7 - thk.5
Body	IN	inlet - 1/4" GAS
	OUT	outlet - 1/4" GAS
Cover	A	standard



**XU017**

**Technical data table**

TYPE	Displacement cm3/rev	Max. Pressure		CODE	
		P1 bar	P3 bar	Left rotation	Right rotation
XV-OU/0.45	0,45	220	280	X 0 U 04 21 B B B A	X 0 U 04 22 B B B A
XV-OU/0.57	0,56	220	280	X 0 U 05 21 B B B A	X 0 U 05 22 B B B A
XV-OU/0.76	0,75	200	260	X 0 U 06 21 B B B A	X 0 U 06 22 B B B A
XV-OU/0.98	0,92	200	260	X 0 U 07 21 B B B A	X 0 U 07 22 B B B A
XV-OU/1.27	1,26	200	260	X 0 U 09 21 B B B A	X 0 U 09 22 B B B A
XV-OU/1.52	1,48	200	260	X 0 U 11 21 B B B A	X 0 U 11 22 B B B A
XV-OU/2.30	2,28	160	190	X 0 U 13 21 B B B A	X 0 U 13 22 B B B A

P1) Max. working pressure - P3) Max. peak pressure

For heavy-duty applications, it is recommended to check the admissible torque of the shaft

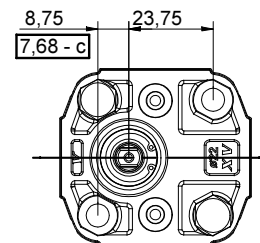
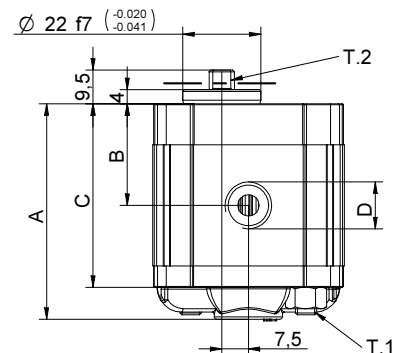
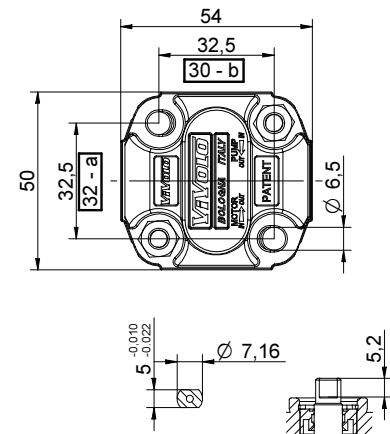

07/12/04 X0P0622888A.dft

**Dimensions table**

TYPE	Weight kg	A	B	C	D	D
		mm	mm	mm	IN	OUT
XV-OU/0.45	0,420	58,0	27,3	49,0	1/4" BSPP	1/4" BSPP
XV-OU/0.57	0,430	59,0	27,8	50,0	1/4" BSPP	1/4" BSPP
XV-OU/0.76	0,440	60,5	28,5	51,5	1/4" BSPP	1/4" BSPP
XV-OU/0.98	0,460	62,0	29,3	53,0	1/4" BSPP	1/4" BSPP
XV-OU/1.27	0,480	64,5	30,5	55,5	1/4" BSPP	1/4" BSPP
XV-OU/1.52	0,500	66,5	31,5	57,5	1/4" BSPP	1/4" BSPP
XV-OU/2.30	0,560	72,5	34,5	63,5	1/4" BSPP	1/4" BSPP

T.1 = 11.7÷13.7 [Nm] - screw tightening torque M6

T.2 = 9.2 [Nm] - admissible shaft torque (N.B. When choosing a shaft, always check the admissible torque).

**NOTE: This type of pump is also interchangeable with distance between centres of fastening in M5 (see dim. a, b, c).**

# Table of variations

**XV-OU**

## ø22 "HY" Body-Shaped FLANGE

ø22 "HY" Body-Shaped FLANGE				Shaft				Cover			
Left rotation		Right rotation						Left rotation		Right rotation	
	21		22	CI001 - Parallel T.2 = 2.1 [Nm]	A	CF001 - Milled shank T.2 = 9.2 [Nm]	B			A	
	23		24	CF005 - Milled shank T.2 = 8.4 [Nm]	F	CO001 - Tapered T.2 = 21.9 [Nm]	E			B	
	25		26							C	
	27		28							D	

Displacement	
TYPE	CODE
XV-OU/0.45	04
XV-OU/0.57	05
XV-OU/0.76	06
XV-OU/0.98	07
XV-OU/1.27	09
XV-OU/1.52	11
XV-OU/2.30	13

Standard bodies				
Displacement cm <sup>3</sup> /rev	Standard threads			
	0.17	B - B	Z - B	Z - Z
0.25	B - B	Z - B	Z - Z	
0.45	B - B	Z - B	Z - Z	
0.57	B - B	Z - B	Z - Z	
0.76	B - B	Z - B	Z - Z	
0.98	B - B	Z - B	Z - Z	
1.27	B - B	Z - B	Z - Z	
1.52	B - B	Z - B	Z - Z	
2.30	B - B	Z - B	Z - Z	

Table showing standard flange and thread combinations available in stock

	N
	O

Body (threads/flanges)													
	A		B		C		D		E		F		G
	H		I	Closed Body		Z							

# unidirectional motor - series XV

XV-1U

STANDARD EUROPEAN MOTOR  
 ø25.4 FLANGE - TAPER SHAFT

**X 1 U 25 02 F I I A**

Series	X	series XV
Group	1	group 1
Category	U	unidirectional motor
Displacement	25	3.8
Flange	02	Ø25.4 STANDARD EUROPEAN right rotation
Shaft	F	CO001 - Tapered 1:8 - ø10 - M7x1 - key thk.2.4
Body	IN	inlet - Ø30 Ø12 M6
	OUT	outlet - Ø30 Ø12 M6
Cover	A	standard

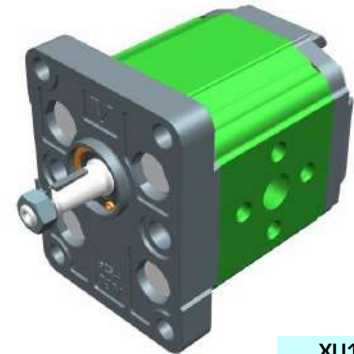

XU101

### Technical data table

TYPE	Displacement cm3/rev	Max. Pressure		CODE	
		P1 bar	P3 bar	Left rotation	Right rotation
XV-1U/0.9	0,91	240	280	X 1 U 16 01 F I I A	X 1 U 16 02 F I I A
XV-1U/1.2	1,17	250	290	X 1 U 17 01 F I I A	X 1 U 17 02 F I I A
XV-1U/1.7	1,56	250	290	X 1 U 18 01 F I I A	X 1 U 18 02 F I I A
XV-1U/2.2	2,08	250	290	X 1 U 20 01 F I I A	X 1 U 20 02 F I I A
XV-1U/2.6	2,60	250	300	X 1 U 21 01 F I I A	X 1 U 21 02 F I I A
XV-1U/3.2	3,12	250	300	X 1 U 23 01 F I I A	X 1 U 23 02 F I I A
XV-1U/3.8	3,64	250	300	X 1 U 25 01 F I I A	X 1 U 25 02 F I I A
XV-1U/4.3	4,16	250	300	X 1 U 27 01 F I I A	X 1 U 27 02 F I I A
XV-1U/4.9	4,94	250	300	X 1 U 29 01 F I I A	X 1 U 29 02 F I I A
XV-1U/5.9	5,85	250	300	X 1 U 31 01 F I I A	X 1 U 31 02 F I I A
XV-1U/6.5	6,50	250	300	X 1 U 32 01 F I I A	X 1 U 32 02 F I I A
XV-1U/7.8	7,54	220	260	X 1 U 34 01 F I I A	X 1 U 34 02 F I I A
XV-1U/9.8	9,88	190	230	X 1 U 36 01 F I I A	X 1 U 36 02 F I I A

P1) Max. working pressure - P3) Max. peak pressure

For heavy-duty applications, it is recommended to check the admissible torque of the shaft

### Dimensions table

TYPE	Weight kg	A	B	C	D	E	F	D	E	F
		mm	mm	mm	IN	IN	IN	OUT	OUT	OUT
XV-1U/0.9	0,950	78,1	37,3	66,1	ø12	30	M6x1	ø12	30	M6x1
XV-1U/1.2	0,970	79,0	37,8	67,0	ø12	30	M6x1	ø12	30	M6x1
XV-1U/1.7	1,010	80,5	38,5	68,5	ø12	30	M6x1	ø12	30	M6x1
XV-1U/2.2	1,030	82,5	39,5	70,5	ø12	30	M6x1	ø12	30	M6x1
XV-1U/2.6	1,060	84,5	40,5	72,5	ø12	30	M6x1	ø12	30	M6x1
XV-1U/3.2	1,090	86,5	41,5	74,5	ø12	30	M6x1	ø12	30	M6x1
XV-1U/3.8	1,120	88,5	42,5	76,5	ø12	30	M6x1	ø12	30	M6x1
XV-1U/4.3	1,170	90,5	43,5	78,5	ø12	30	M6x1	ø12	30	M6x1
XV-1U/4.9	1,200	93,5	45,0	81,5	ø12	30	M6x1	ø12	30	M6x1
XV-1U/5.9	1,260	97,0	46,8	85,0	ø12	30	M6x1	ø12	30	M6x1
XV-1U/6.5	1,300	98,5	48,0	86,5	ø12	30	M6x1	ø12	30	M6x1
XV-1U/7.8	1,360	103,5	50,0	91,5	ø12	30	M6x1	ø12	30	M6x1
XV-1U/9.8	1,500	112,5	54,5	100,5	ø12	30	M6x1	ø12	30	M6x1

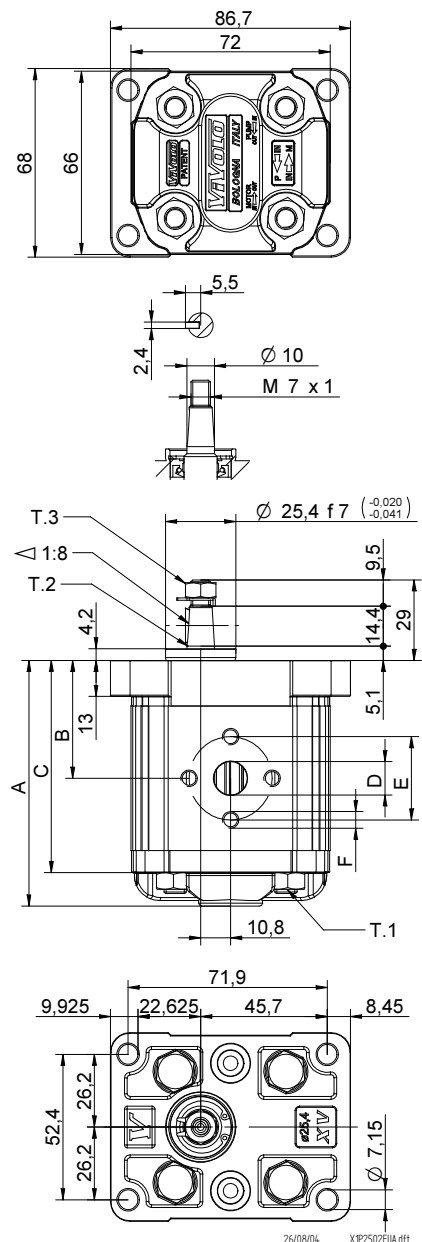

T.1 = 24.5÷29.4 [Nm] - screw tightening torque M8

T.3 = 11.5 [Nm] - torque wrench setting 11

T.2 = 43 [Nm] - admissible shaft torque (N.B. When choosing a shaft, always check the admissible torque).

# Table of variations

**XV-1U**

## ø25.4 FLANGE

ø25.4 FLANGE				Shaft				Cover			
Left rotation		Right rotation						Left rotation		Right rotation	
	<b>01</b>		<b>02</b>	CO001 - Tapered T.2 = 43 [Nm]		CF002 - Milled shank T.2 = 13.8 [Nm]					
	<b>03</b>		<b>04</b>	SCF04 - Splined T.2 = 22.6 [Nm] m=1.6 Z=6 DIN 5482 - 12x9		SCF02 - Splined T.2 = 42.8 [Nm] m=0.75 Z=15					
	<b>05</b>		<b>06</b>	SCF01 - Splined T.2 = 42.8 [Nm] m=0.75 Z=15		SCF03 - Splined T.2 = 42.8 [Nm] m=0.75 Z=15					
	<b>07</b>		<b>08</b>								

Displacement	
TYPE	CODE
XV-1U/0.9	<b>16</b>
XV-1U/1.2	<b>17</b>
XV-1U/1.7	<b>18</b>
XV-1U/2.2	<b>20</b>
XV-1U/2.6	<b>21</b>
XV-1U/3.2	<b>23</b>
XV-1U/3.8	<b>25</b>
XV-1U/4.3	<b>27</b>
XV-1U/4.9	<b>29</b>
XV-1U/5.9	<b>31</b>
XV-1U/6.5	<b>32</b>
XV-1U/7.8	<b>34</b>
XV-1U/9.8	<b>36</b>

Standard bodies							
Displacement cm3/rev	Standard threads						
	0.9	I - I	B - B	J - J	B - Z	Z - Z	G - F
1.2	I - I	B - B	J - J	B - Z	Z - Z	G - F	
1.7	I - I	B - B	J - J	B - Z	Z - Z	G - F	
2.2	I - I	B - B	J - J	B - Z	Z - Z	G - F	
2.6	I - I	B - B	J - J	B - Z	Z - Z	G - F	
3.2	I - I	B - B	J - J	B - Z	Z - Z	G - F	
3.8	I - I	B - B	J - J	B - Z	Z - Z	G - F	
4.3	I - I	B - B	J - J	B - Z	Z - Z	G - F	
4.9	I - I	B - B	J - J	B - Z	Z - Z	G - F	
5.9	I - I	B - B	J - J	B - Z	Z - Z	G - F	
6.5	I - I	B - B	J - J	B - Z	Z - Z	G - F	
7.8	I - I	B - B	J - J	B - Z	Z - Z	G - F	
9.8	I - I	B - B	J - J	B - Z	Z - Z	G - F	

Table showing standard flange and thread combinations available in stock

		<b>N</b>
Internal drainage		
		<b>O</b>
External drainage		

Body (threads/flanges)													
	<b>A</b>		<b>B</b>		<b>C</b>		<b>D</b>		<b>E</b>		<b>F</b>		<b>G</b>
	<b>H</b>		<b>I</b>		<b>J</b>		<b>Z</b>						
Closed Body													

# unidirectional motor - series XV

STANDARD EUROPEAN MOTOR  
 ø25.4 FLANGE - TAPER SHAFT

XV-1U

**X 1 U 25 02 F B B A**

Series	X	series XV
Group	1	group 1
Category	U	unidirectional motor
Displacement	25	3.8
Flange	02	Ø25.4 STANDARD EUROPEAN right rotation
Shaft	F	CO001 - Tapered 1:8 - ø10 - M7x1 - key thk.2.4
Body	IN	inlet - 3/8" GAS
	OUT	outlet - 3/8" GAS
Cover	A	standard

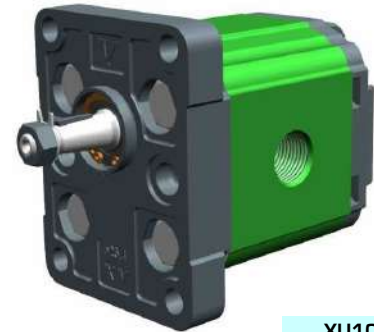

XU105

Technical data table

TYPE	Displacement cm3/rev	Max. Pressure		CODE			
		P1 bar	P3 bar	Left rotation		Right rotation	
XV-1U/0.9	0,91	240	280	X 1 U 16 01	F B B A	X 1 U 16 02	F B B A
XV-1U/1.2	1,17	250	290	X 1 U 17 01	F B B A	X 1 U 17 02	F B B A
XV-1U/1.7	1,56	250	290	X 1 U 18 01	F B B A	X 1 U 18 02	F B B A
XV-1U/2.2	2,08	250	290	X 1 U 20 01	F B B A	X 1 U 20 02	F B B A
XV-1U/2.6	2,60	250	300	X 1 U 21 01	F B B A	X 1 U 21 02	F B B A
XV-1U/3.2	3,12	250	300	X 1 U 23 01	F B B A	X 1 U 23 02	F B B A
XV-1U/3.8	3,64	250	300	X 1 U 25 01	F B B A	X 1 U 25 02	F B B A
XV-1U/4.3	4,16	250	300	X 1 U 27 01	F B B A	X 1 U 27 02	F B B A
XV-1U/4.9	4,94	250	300	X 1 U 29 01	F B B A	X 1 U 29 02	F B B A
XV-1U/5.9	5,85	250	300	X 1 U 31 01	F B B A	X 1 U 31 02	F B B A
XV-1U/6.5	6,50	250	300	X 1 U 32 01	F B B A	X 1 U 32 02	F B B A
XV-1U/7.8	7,54	220	260	X 1 U 34 01	F B B A	X 1 U 34 02	F B B A
XV-1U/9.8	9,88	190	230	X 1 U 36 01	F B B A	X 1 U 36 02	F B B A

P1) Max. working pressure - P3) Max. peak pressure

For heavy-duty applications, it is recommended to check the admissible torque of the shaft

Dimensions table

TYPE	Weight kg	A	B	C	D	
		mm	mm	mm	IN	OUT
XV-1U/0.9	0,950	78,1	37,3	66,1	3/8" BSPP	3/8" BSPP
XV-1U/1.2	0,970	79,0	37,8	67,0	3/8" BSPP	3/8" BSPP
XV-1U/1.7	1,010	80,5	38,5	68,5	3/8" BSPP	3/8" BSPP
XV-1U/2.2	1,030	82,5	39,5	70,5	3/8" BSPP	3/8" BSPP
XV-1U/2.6	1,060	84,5	40,5	72,5	3/8" BSPP	3/8" BSPP
XV-1U/3.2	1,090	86,5	41,5	74,5	3/8" BSPP	3/8" BSPP
XV-1U/3.8	1,120	88,5	42,5	76,5	3/8" BSPP	3/8" BSPP
XV-1U/4.3	1,170	90,5	43,5	78,5	3/8" BSPP	3/8" BSPP
XV-1U/4.9	1,200	93,5	45,0	81,5	3/8" BSPP	3/8" BSPP
XV-1U/5.9	1,260	97,0	46,8	85,0	3/8" BSPP	3/8" BSPP
XV-1U/6.5	1,300	98,5	48,0	86,5	3/8" BSPP	3/8" BSPP
XV-1U/7.8	1,360	103,5	50,0	91,5	3/8" BSPP	3/8" BSPP
XV-1U/9.8	1,500	112,5	54,5	100,5	3/8" BSPP	3/8" BSPP

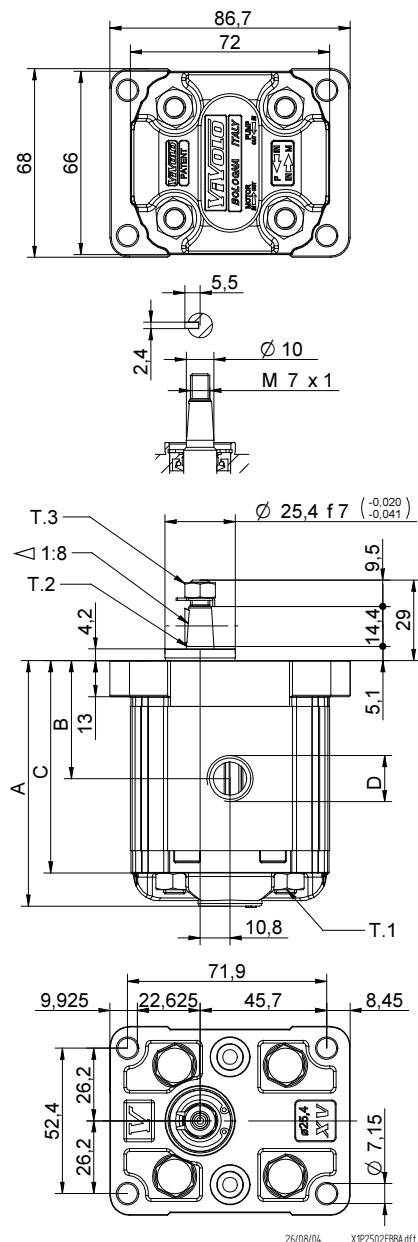

26/08/04 X1P2502FBBAff

T.1 = 24.5÷29.4 [Nm] - screw tightening torque M8

T.3 = 11.5 [Nm] - torque wrench setting 11

T.2 = 43 [Nm] - admissible shaft torque (N.B. When choosing a shaft, always check the admissible torque).

# Table of variations

**XV-1U**

## ø25.4 FLANGE

ø25.4 FLANGE				Shaft				Cover			
Left rotation		Right rotation						Left rotation		Right rotation	
	<b>01</b>		<b>02</b>	CO001 - Tapered T.2 = 43 [Nm]	<b>F</b>	CF002 - Milled shank T.2 = 13.8 [Nm]	<b>D</b>				<b>A</b>
	<b>03</b>		<b>04</b>	SCF04 - Splined T.2 = 22.6 [Nm] m=1.6 Z=6 DIN 5482 - 12x9	<b>J</b>	SCF02 - Splined T.2 = 42.8 [Nm] m=0.75 Z=15	<b>L</b>				<b>B</b>
	<b>05</b>		<b>06</b>	SCF01 - Splined T.2 = 42.8 [Nm] m=0.75 Z=15	<b>Q</b>	SCF03 - Splined T.2 = 42.8 [Nm] m=0.75 Z=15	<b>R</b>				<b>C</b>
	<b>07</b>		<b>08</b>								<b>D</b>

Displacement	
TYPE	CODE
XV-1U/0.9	<b>16</b>
XV-1U/1.2	<b>17</b>
XV-1U/1.7	<b>18</b>
XV-1U/2.2	<b>20</b>
XV-1U/2.6	<b>21</b>
XV-1U/3.2	<b>23</b>
XV-1U/3.8	<b>25</b>
XV-1U/4.3	<b>27</b>
XV-1U/4.9	<b>29</b>
XV-1U/5.9	<b>31</b>
XV-1U/6.5	<b>32</b>
XV-1U/7.8	<b>34</b>
XV-1U/9.8	<b>36</b>

Standard bodies							
Displacement cm3/rev	Standard threads						
	0.9	I - I	B - B	J - J	B - Z	Z - Z	G - F
1.2	I - I	B - B	J - J	B - Z	Z - Z	G - F	
1.7	I - I	B - B	J - J	B - Z	Z - Z	G - F	
2.2	I - I	B - B	J - J	B - Z	Z - Z	G - F	
2.6	I - I	B - B	J - J	B - Z	Z - Z	G - F	
3.2	I - I	B - B	J - J	B - Z	Z - Z	G - F	
3.8	I - I	B - B	J - J	B - Z	Z - Z	G - F	
4.3	I - I	B - B	J - J	B - Z	Z - Z	G - F	
4.9	I - I	B - B	J - J	B - Z	Z - Z	G - F	
5.9	I - I	B - B	J - J	B - Z	Z - Z	G - F	
6.5	I - I	B - B	J - J	B - Z	Z - Z	G - F	
7.8	I - I	B - B	J - J	B - Z	Z - Z	G - F	
9.8	I - I	B - B	J - J	B - Z	Z - Z	G - F	

Table showing standard flange and thread combinations available in stock

		<b>N</b>
Internal drainage		
		<b>O</b>
External drainage		

Body (threads/flanges)													
	<b>A</b>		<b>B</b>		<b>C</b>		<b>D</b>		<b>E</b>		<b>F</b>		<b>G</b>
	<b>H</b>		<b>I</b>		<b>J</b>		<b>Z</b>	Closed Body					

# unidirectional motor - series XV

XV-1U

STANDARD MOTOR  
ø30 FLANGE - TAPER SHAFT

**X 1 U 25 12 G I I A**

Series	X	series XV
Group	1	group 1
Category	U	unidirectional motor
Displacement	25	3.8
Flange	12	Ø30 STANDARD right rotation
Shaft	G	CO002 - Tapered 1:8 - ø14 - M10x1 - key thk.3
Body	IN	I inlet - Ø30 Ø12 M6
	OUT	I outlet - Ø30 Ø12 M6
Cover	A	standard

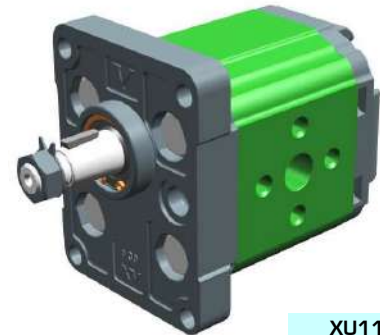

XU113

### Technical data table

TYPE	Displacement cm3/rev	Max. Pressure		CODE	
		P1 bar	P3 bar	Left rotation	Right rotation
XV-1U/0.9	0,91	240	280	X 1 U 16 11 G I I A	X 1 U 16 12 G I I A
XV-1U/1.2	1,17	250	290	X 1 U 17 11 G I I A	X 1 U 17 12 G I I A
XV-1U/1.7	1,56	250	290	X 1 U 18 11 G I I A	X 1 U 18 12 G I I A
XV-1U/2.2	2,08	250	290	X 1 U 20 11 G I I A	X 1 U 20 12 G I I A
XV-1U/2.6	2,60	250	300	X 1 U 21 11 G I I A	X 1 U 21 12 G I I A
XV-1U/3.2	3,12	250	300	X 1 U 23 11 G I I A	X 1 U 23 12 G I I A
XV-1U/3.8	3,64	250	300	X 1 U 25 11 G I I A	X 1 U 25 12 G I I A
XV-1U/4.3	4,16	250	300	X 1 U 27 11 G I I A	X 1 U 27 12 G I I A
XV-1U/4.9	4,94	250	300	X 1 U 29 11 G I I A	X 1 U 29 12 G I I A
XV-1U/5.9	5,85	250	300	X 1 U 31 11 G I I A	X 1 U 31 12 G I I A
XV-1U/6.5	6,50	250	300	X 1 U 32 11 G I I A	X 1 U 32 12 G I I A
XV-1U/7.8	7,54	220	260	X 1 U 34 11 G I I A	X 1 U 34 12 G I I A

P1) Max. working pressure - P3) Max. peak pressure

For heavy-duty applications, it is recommended to check the admissible torque of the shaft

### Dimensions table

TYPE	Weight kg	A	B	C	D	E	F	D	E	F
		mm	mm	mm	IN	OUT				
XV-1U/0.9	0,950	78,1	37,3	66,1	ø12	30	M6x1	ø12	30	M6x1
XV-1U/1.2	0,970	79,0	37,8	67,0	ø12	30	M6x1	ø12	30	M6x1
XV-1U/1.7	1,010	80,5	38,5	68,5	ø12	30	M6x1	ø12	30	M6x1
XV-1U/2.2	1,030	82,5	39,5	70,5	ø12	30	M6x1	ø12	30	M6x1
XV-1U/2.6	1,060	84,5	40,5	72,5	ø12	30	M6x1	ø12	30	M6x1
XV-1U/3.2	1,090	86,5	41,5	74,5	ø12	30	M6x1	ø12	30	M6x1
XV-1U/3.8	1,120	88,5	42,5	76,5	ø12	30	M6x1	ø12	30	M6x1
XV-1U/4.3	1,170	90,5	43,5	78,5	ø12	30	M6x1	ø12	30	M6x1
XV-1U/4.9	1,200	93,5	45,0	81,5	ø12	30	M6x1	ø12	30	M6x1
XV-1U/5.9	1,260	97,0	46,8	85,0	ø12	30	M6x1	ø12	30	M6x1
XV-1U/6.5	1,300	98,5	48,0	86,5	ø12	30	M6x1	ø12	30	M6x1
XV-1U/7.8	1,360	103,5	50,0	91,5	ø12	30	M6x1	ø12	30	M6x1

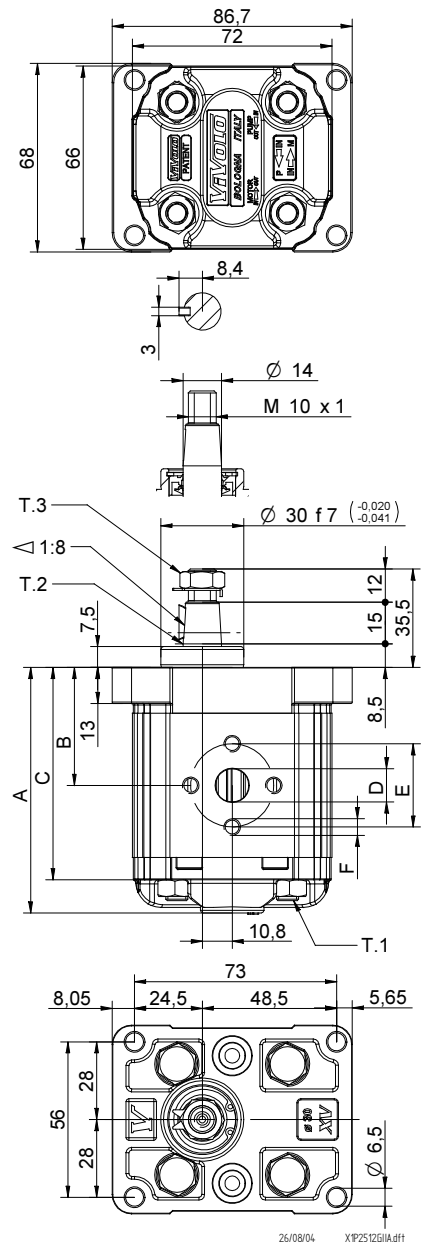

T.1 = 24.5÷29.4 [Nm] - screw tightening torque M8

T.3 = 13 [Nm] - torque wrench setting 17

T.2 = 119.8 [Nm] - admissible shaft torque (N.B. When choosing a shaft, always check the admissible torque).

# Table of variations

**XV-1U**

## ø30 FLANGE

ø30 FLANGE				Shaft				Cover			
Left rotation		Right rotation						Left rotation		Right rotation	
	<b>11</b>		<b>12</b>	CI001 - Parallel T.2 = 25.8 [Nm]	<b>A</b>	CO002 - Tapered T.2 = 119.8 [Nm]	<b>G</b>				<b>A</b>
	<b>13</b>		<b>14</b>	CI001+HK - Parallel T.2 = 25.8 [Nm]	<b>P</b>	CO002+HK - Tapered T.2 = 119.8 [Nm]	<b>O</b>				<b>B</b>
	<b>15</b>		<b>16</b>								<b>C</b>
	<b>17</b>		<b>18</b>								<b>D</b>

Displacement	
TYPE	CODE
XV-1U/0.9	<b>16</b>
XV-1U/1.2	<b>17</b>
XV-1U/1.7	<b>18</b>
XV-1U/2.2	<b>20</b>
XV-1U/2.6	<b>21</b>
XV-1U/3.2	<b>23</b>
XV-1U/3.8	<b>25</b>
XV-1U/4.3	<b>27</b>
XV-1U/4.9	<b>29</b>
XV-1U/5.9	<b>31</b>
XV-1U/6.5	<b>32</b>
XV-1U/7.8	<b>34</b>

Displacement cm3/rev	Standard bodies						
	Standard threads						
0.9	I-I	B-B	J-J	B-Z	Z-Z	G-F	
1.2	I-I	B-B	J-J	B-Z	Z-Z	G-F	
1.7	I-I	B-B	J-J	B-Z	Z-Z	G-F	
2.2	I-I	B-B	J-J	B-Z	Z-Z	G-F	
2.6	I-I	B-B	J-J	B-Z	Z-Z	G-F	
3.2	I-I	B-B	J-J	B-Z	Z-Z	G-F	
3.8	I-I	B-B	J-J	B-Z	Z-Z	G-F	
4.3	I-I	B-B	J-J	B-Z	Z-Z	G-F	
4.9	I-I	B-B	J-J	B-Z	Z-Z	G-F	
5.9	I-I	B-B	J-J	B-Z	Z-Z	G-F	
6.5	I-I	B-B	J-J	B-Z	Z-Z	G-F	
7.8	I-I	B-B	J-J	B-Z	Z-Z	G-F	
9.8	I-I	B-B	J-J	B-Z	Z-Z	G-F	

Table showing standard flange and thread combinations available in stock

	<b>N</b>
	<b>O</b>

Body (threads/flanges)							
	<b>A</b>		<b>B</b>		<b>C</b>		<b>D</b>
	<b>E</b>		<b>F</b>		<b>G</b>		
	<b>H</b>		<b>I</b>		<b>J</b>	<b>Closed Body</b>	<b>Z</b>



# Table of variations

**XV-1U**

## ø32 "BH" Body-Shaped FLANGE

ø32 "BH" Body-Shaped FLANGE				Shaft				Cover			
Left rotation		Right rotation						Left rotation		Right rotation	
	41		42	CF002 - Milled shank T.2 = 13.8 [Nm] 	D	CO001 - Tapered T.2 = 43 [Nm] 	F				A
	43		44	SCF02 - Splined T.2 = 42.8 [Nm] m=0,75 Z=15 	L	SCF04 - Splined T.2 = 22.6 [Nm] m=1,6 Z=6 DIN 5482 - 12x9 	J				B
	45		46	SCF01 - Splined T.2 = 42.8 [Nm] m=0,75 Z=15 	Q	SCF03 - Splined T.2 = 42.8 [Nm] m=0,75 Z=15 	R				C
	47		48								D

Displacement	
TYPE	CODE
XV-1U/0.9	16
XV-1U/1.2	17
XV-1U/1.7	18
XV-1U/2.2	20
XV-1U/2.6	21
XV-1U/3.2	23
XV-1U/3.8	25
XV-1U/4.3	27
XV-1U/4.9	29
XV-1U/5.9	31
XV-1U/6.5	32
XV-1U/7.8	34
XV-1U/9.8	36

Standard bodies							
Displacement cm3/rev	Standard threads						
	0.9	I - I	B - B	J - J	B - Z	Z - Z	G - F
1.2	I - I	B - B	J - J	B - Z	Z - Z	G - F	
1.7	I - I	B - B	J - J	B - Z	Z - Z	G - F	
2.2	I - I	B - B	J - J	B - Z	Z - Z	G - F	
2.6	I - I	B - B	J - J	B - Z	Z - Z	G - F	
3.2	I - I	B - B	J - J	B - Z	Z - Z	G - F	
3.8	I - I	B - B	J - J	B - Z	Z - Z	G - F	
4.3	I - I	B - B	J - J	B - Z	Z - Z	G - F	
4.9	I - I	B - B	J - J	B - Z	Z - Z	G - F	
5.9	I - I	B - B	J - J	B - Z	Z - Z	G - F	
6.5	I - I	B - B	J - J	B - Z	Z - Z	G - F	
7.8	I - I	B - B	J - J	B - Z	Z - Z	G - F	
9.8	I - I	B - B	J - J	B - Z	Z - Z	G - F	

Table showing standard flange and thread combinations available in stock

				N
Internal drainage				
				O
External drainage				

Body (threads/flanges)													
	A		B		C		D		E		F		G
	H		I		J	Closed Body	Z						

# unidirectional motor - series XV

XV-1U

HY TYPE MOTOR  
 ø32 BODY-SHAPED FLANGE - MILLED SHANK

**X 1 U 25 52 D B B A**

Series	X	series XV
Group	1	group 1
Category	U	unidirectional motor
Displacement	25	3.8
Flange	52	Ø32 HY right rotation
Shaft	D	CF002 - Milled shank ø10 - thk.5
Body	IN	inlet - 3/8" GAS
	OUT	outlet - 3/8" GAS
Cover	A	standard



XU140

Technical data table						
TYPE	Displacement cm3/rev	Max. Pressure		CODE		
		P1 bar	P3 bar	Left rotation		Right rotation
XV-1U/0.9	0,91	240	280	X 1 U 16 51 D B B A	X 1 U 16 52 D B B A	X 1 U 16 52 D B B A
XV-1U/1.2	1,17	250	290	X 1 U 17 51 D B B A	X 1 U 17 52 D B B A	X 1 U 17 52 D B B A
XV-1U/1.7	1,56	250	290	X 1 U 18 51 D B B A	X 1 U 18 52 D B B A	X 1 U 18 52 D B B A
XV-1U/2.2	2,08	250	290	X 1 U 20 51 D B B A	X 1 U 20 52 D B B A	X 1 U 20 52 D B B A
XV-1U/2.6	2,60	250	300	X 1 U 21 51 D B B A	X 1 U 21 52 D B B A	X 1 U 21 52 D B B A
XV-1U/3.2	3,12	250	300	X 1 U 23 51 D B B A	X 1 U 23 52 D B B A	X 1 U 23 52 D B B A
XV-1U/3.8	3,64	250	300	X 1 U 25 51 D B B A	X 1 U 25 52 D B B A	X 1 U 25 52 D B B A
XV-1U/4.3	4,16	250	300	X 1 U 27 51 D B B A	X 1 U 27 52 D B B A	X 1 U 27 52 D B B A
XV-1U/4.9	4,94	250	300	X 1 U 29 51 D B B A	X 1 U 29 52 D B B A	X 1 U 29 52 D B B A
XV-1U/5.9	5,85	250	300	X 1 U 31 51 D B B A	X 1 U 31 52 D B B A	X 1 U 31 52 D B B A
XV-1U/6.5	6,50	250	300	X 1 U 32 51 D B B A	X 1 U 32 52 D B B A	X 1 U 32 52 D B B A
XV-1U/7.8	7,54	220	260	X 1 U 34 51 D B B A	X 1 U 34 52 D B B A	X 1 U 34 52 D B B A
XV-1U/9.8	9,88	190	230	X 1 U 36 51 D B B A	X 1 U 36 52 D B B A	X 1 U 36 52 D B B A

P1) Max. working pressure - P3) Max. peak pressure

For heavy-duty applications, it is recommended to check the admissible torque of the shaft

Dimensions table						
TYPE	Weight kg	A	B	C	D	D
		mm	mm	mm	IN	OUT
XV-1U/0.9	0,950	77,1	36,3	65,1	3/8" BSPP	3/8" BSPP
XV-1U/1.2	0,970	78,0	36,8	66,0	3/8" BSPP	3/8" BSPP
XV-1U/1.7	1,010	79,5	37,5	67,5	3/8" BSPP	3/8" BSPP
XV-1U/2.2	1,030	81,5	38,5	69,5	3/8" BSPP	3/8" BSPP
XV-1U/2.6	1,060	83,5	39,5	71,5	3/8" BSPP	3/8" BSPP
XV-1U/3.2	1,090	85,5	40,5	73,5	3/8" BSPP	3/8" BSPP
XV-1U/3.8	1,120	87,5	41,5	75,5	3/8" BSPP	3/8" BSPP
XV-1U/4.3	1,170	89,5	42,5	77,5	3/8" BSPP	3/8" BSPP
XV-1U/4.9	1,200	92,5	44,0	80,5	3/8" BSPP	3/8" BSPP
XV-1U/5.9	1,260	96,0	45,8	84,0	3/8" BSPP	3/8" BSPP
XV-1U/6.5	1,300	97,5	47,0	85,5	3/8" BSPP	3/8" BSPP
XV-1U/7.8	1,360	102,5	49,0	90,5	3/8" BSPP	3/8" BSPP
XV-1U/9.8	1,500	111,5	53,5	99,5	3/8" BSPP	3/8" BSPP

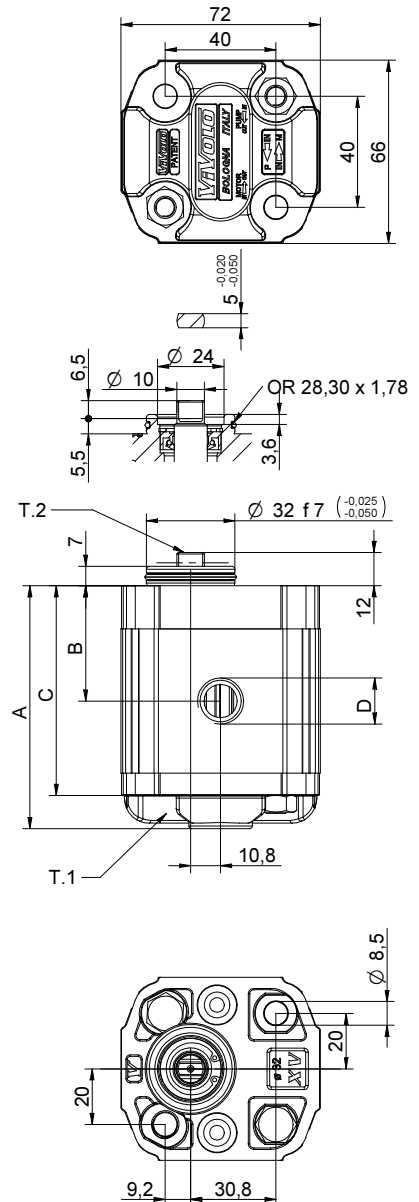

26/08/04 X1P25S2DBBA.dft

T.1 = 24.5÷29.4 [Nm] - screw tightening torque M8

T.2 = 13.8 [Nm] - admissible shaft torque (N.B. When choosing a shaft, always check the admissible torque).

# Table of variations

**XV-1U**

## ø32 "HY" Body-Shaped FLANGE

ø32 "HY" Body-Shaped FLANGE				Shaft				Cover			
Left rotation		Right rotation						Left rotation		Right rotation	
	<b>51</b>		<b>52</b>	CF002 - Milled shank T.2 = 13.8 [Nm] 	<b>D</b>	CO001 - Tapered T.2 = 43 [Nm] 	<b>F</b>			<b>A</b>	
	<b>53</b>		<b>54</b>	SCF02 - Splined T.2 = 42.8 [Nm] m=0,75 Z=15 	<b>L</b>	SCF04 - Splined T.2 = 22.6 [Nm] m=1,6 Z=6 DIN 5482 - 12x9 	<b>J</b>			<b>B</b>	
	<b>55</b>		<b>56</b>	SCF01 - Splined T.2 = 42.8 [Nm] m=0,75 Z=15 	<b>Q</b>	SCF03 - Splined T.2 = 42.8 [Nm] m=0,75 Z=15 	<b>R</b>			<b>C</b>	
	<b>57</b>		<b>58</b>							<b>D</b>	

Displacement	
TYPE	CODE
XV-1U/0.9	<b>16</b>
XV-1U/1.2	<b>17</b>
XV-1U/1.7	<b>18</b>
XV-1U/2.2	<b>20</b>
XV-1U/2.6	<b>21</b>
XV-1U/3.2	<b>23</b>
XV-1U/3.8	<b>25</b>
XV-1U/4.3	<b>27</b>
XV-1U/4.9	<b>29</b>
XV-1U/5.9	<b>31</b>
XV-1U/6.5	<b>32</b>
XV-1U/7.8	<b>34</b>
XV-1U/9.8	<b>36</b>

Standard bodies							
Displacement cm3/rev	Standard threads						
	0.9	I - I	B - B	J - J	B - Z	Z - Z	G - F
1.2	I - I	B - B	J - J	B - Z	Z - Z	G - F	
1.7	I - I	B - B	J - J	B - Z	Z - Z	G - F	
2.2	I - I	B - B	J - J	B - Z	Z - Z	G - F	
2.6	I - I	B - B	J - J	B - Z	Z - Z	G - F	
3.2	I - I	B - B	J - J	B - Z	Z - Z	G - F	
3.8	I - I	B - B	J - J	B - Z	Z - Z	G - F	
4.3	I - I	B - B	J - J	B - Z	Z - Z	G - F	
4.9	I - I	B - B	J - J	B - Z	Z - Z	G - F	
5.9	I - I	B - B	J - J	B - Z	Z - Z	G - F	
6.5	I - I	B - B	J - J	B - Z	Z - Z	G - F	
7.8	I - I	B - B	J - J	B - Z	Z - Z	G - F	
9.8	I - I	B - B	J - J	B - Z	Z - Z	G - F	

Table showing standard flange and thread combinations available in stock

		<b>N</b>
Internal drainage		
		<b>O</b>
External drainage		

Body (threads/flanges)							
	<b>A</b>		<b>B</b>		<b>C</b>		<b>D</b>
	<b>E</b>		<b>F</b>		<b>G</b>		
	<b>H</b>		<b>I</b>		<b>J</b>	<b>Closed Body</b>	<b>Z</b>

# unidirectional motor - series XV

XV-1U

STANDARD GERMAN "BH" TYPE MOTOR  
 ø32 BODY-SHAPED FLANGE - MILLED SHANK

**X 1 U 25 32 C B B A**

Series	X	series XV
Group	1	group 1
Category	U	unidirectional motor
Displacement	25	3.8
Flange	32	Ø32 BH GERMAN STANDARDIZED right rotation
Shaft	C	CF001 - Milled shank ø10 - thk.5 ("BH" Standard German)
Body	IN	inlet - 3/8" GAS
	OUT	outlet - 3/8" GAS
Cover	A	standard



XU161

### Technical data table

TYPE	Displacement cm3/rev	Max. Pressure		CODE	
		P1 bar	P3 bar	Left rotation	Right rotation
XV-1U/0.9	0,91	240	280	X 1 U 16 31 C B B A	X 1 U 16 32 C B B A
XV-1U/1.2	1,17	250	290	X 1 U 17 31 C B B A	X 1 U 17 32 C B B A
XV-1U/1.7	1,56	250	290	X 1 U 18 31 C B B A	X 1 U 18 32 C B B A
XV-1U/2.2	2,08	250	290	X 1 U 20 31 C B B A	X 1 U 20 32 C B B A
XV-1U/2.6	2,60	250	300	X 1 U 21 31 C B B A	X 1 U 21 32 C B B A
XV-1U/3.2	3,12	250	300	X 1 U 23 31 C B B A	X 1 U 23 32 C B B A
XV-1U/3.8	3,64	250	300	X 1 U 25 31 C B B A	X 1 U 25 32 C B B A
XV-1U/4.3	4,16	250	300	X 1 U 27 31 C B B A	X 1 U 27 32 C B B A
XV-1U/4.9	4,94	250	300	X 1 U 29 31 C B B A	X 1 U 29 32 C B B A
XV-1U/5.9	5,85	250	300	X 1 U 31 31 C B B A	X 1 U 31 32 C B B A
XV-1U/6.5	6,50	250	300	X 1 U 32 31 C B B A	X 1 U 32 32 C B B A
XV-1U/7.8	7,54	220	260	X 1 U 34 31 C B B A	X 1 U 34 32 C B B A
XV-1U/9.8	9,88	190	230	X 1 U 36 31 C B B A	X 1 U 36 32 C B B A

P1) Max. working pressure - P3) Max. peak pressure

For heavy-duty applications, it is recommended to check the admissible torque of the shaft

### Dimensions table

TYPE	Weight kg	A	B	C	D	D
		mm	mm	mm	IN	OUT
XV-1U/0.9	0,950	77,1	36,3	65,1	3/8" BSPP	3/8" BSPP
XV-1U/1.2	0,970	78,0	36,8	66,0	3/8" BSPP	3/8" BSPP
XV-1U/1.7	1,010	79,5	37,5	67,5	3/8" BSPP	3/8" BSPP
XV-1U/2.2	1,030	81,5	38,5	69,5	3/8" BSPP	3/8" BSPP
XV-1U/2.6	1,060	83,5	39,5	71,5	3/8" BSPP	3/8" BSPP
XV-1U/3.2	1,090	85,5	40,5	73,5	3/8" BSPP	3/8" BSPP
XV-1U/3.8	1,120	87,5	41,5	75,5	3/8" BSPP	3/8" BSPP
XV-1U/4.3	1,170	89,5	42,5	77,5	3/8" BSPP	3/8" BSPP
XV-1U/4.9	1,200	92,5	44,0	80,5	3/8" BSPP	3/8" BSPP
XV-1U/5.9	1,260	96,0	45,8	84,0	3/8" BSPP	3/8" BSPP
XV-1U/6.5	1,300	97,5	47,0	85,5	3/8" BSPP	3/8" BSPP
XV-1U/7.8	1,360	102,5	49,0	90,5	3/8" BSPP	3/8" BSPP
XV-1U/9.8	1,500	111,5	53,5	99,5	3/8" BSPP	3/8" BSPP

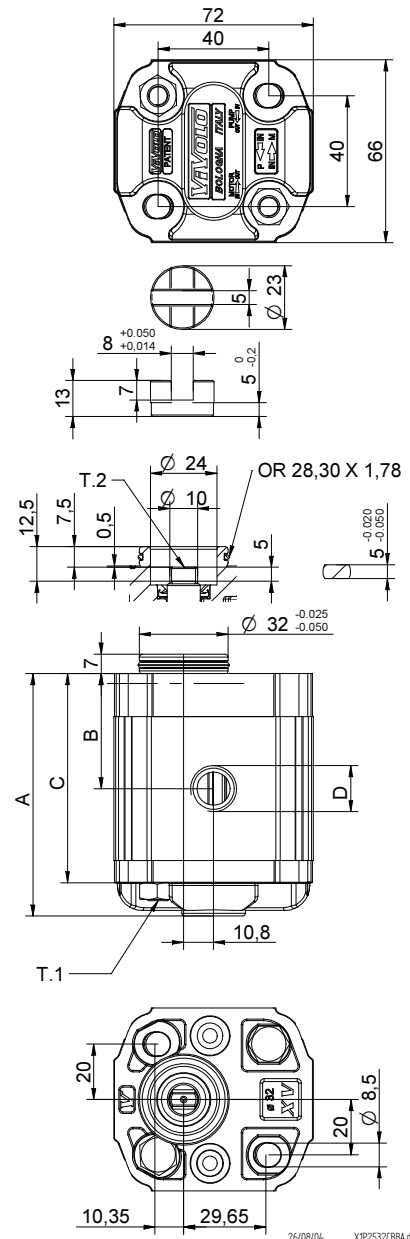

T.1 = 24.5÷29.4 [Nm] - screw tightening torque M8

T.2 = 13.8 [Nm] - admissible shaft torque (N.B. When choosing a shaft, always check the admissible torque).

# Table of variations

**XV-1U**

## Standard German ø32 "BH" FLANGE

Standard German ø32 "BH" FLANGE				Shaft		Cover			
Left rotation		Right rotation				Left rotation	Right rotation		
	<b>31</b>		<b>32</b>	CF001 - Milled shank T.2 = 13.8 [Nm] 	<b>C</b>	SCF01 - Splined T.2 = 42.8 [Nm] m=0,75 Z=15 			<b>A</b>
	<b>33</b>		<b>34</b>	SCF03 - Splined T.2 = 42.8 [Nm] m=0,75 Z=15 	<b>R</b>				<b>B</b>
	<b>35</b>		<b>36</b>						<b>C</b>
	<b>37</b>		<b>38</b>						<b>D</b>

Displacement	
TYPE	CODE
XV-1U/0.9	<b>16</b>
XV-1U/1.2	<b>17</b>
XV-1U/1.7	<b>18</b>
XV-1U/2.2	<b>20</b>
XV-1U/2.6	<b>21</b>
XV-1U/3.2	<b>23</b>
XV-1U/3.8	<b>25</b>
XV-1U/4.3	<b>27</b>
XV-1U/4.9	<b>29</b>
XV-1U/5.9	<b>31</b>
XV-1U/6.5	<b>32</b>
XV-1U/7.8	<b>34</b>
XV-1U/9.8	<b>36</b>

Standard bodies							
Displacement cm3/rev	Standard threads						
	0.9	I - I	B - B	J - J	B - Z	Z - Z	G - F
1.2	I - I	B - B	J - J	B - Z	Z - Z	G - F	
1.7	I - I	B - B	J - J	B - Z	Z - Z	G - F	
2.2	I - I	B - B	J - J	B - Z	Z - Z	G - F	
2.6	I - I	B - B	J - J	B - Z	Z - Z	G - F	
3.2	I - I	B - B	J - J	B - Z	Z - Z	G - F	
3.8	I - I	B - B	J - J	B - Z	Z - Z	G - F	
4.3	I - I	B - B	J - J	B - Z	Z - Z	G - F	
4.9	I - I	B - B	J - J	B - Z	Z - Z	G - F	
5.9	I - I	B - B	J - J	B - Z	Z - Z	G - F	
6.5	I - I	B - B	J - J	B - Z	Z - Z	G - F	
7.8	I - I	B - B	J - J	B - Z	Z - Z	G - F	
9.8	I - I	B - B	J - J	B - Z	Z - Z	G - F	

Table showing standard flange and thread combinations available in stock

		<b>N</b>
Internal drainage		
		<b>O</b>
External drainage		

Body (threads/flanges)							
	<b>A</b>		<b>B</b>		<b>C</b>		<b>D</b>
	<b>E</b>		<b>F</b>		<b>G</b>		
	<b>H</b>		<b>I</b>		<b>J</b>	<b>Closed Body</b>	<b>Z</b>

# unidirectional motor - series XV

XV-1U

SAE AA TYPE MOTOR  
 ø50.8 FLANGE - PARALLEL SHAFT

**X 1 U 25 62 B B B A**

Series	X	series XV
Group	1	group 1
Category	U	unidirectional motor
Displacement	25	3.8
Flange	62	Ø50.8 SAE AA right rotation
Shaft	B	CI002 - Parallel ø12.7 - key thk. 3.2 (SAE AA)
Body	IN	inlet - 3/8" GAS
	OUT	outlet - 3/8" GAS
Cover	A	standard



XU168

Technical data table

TYPE	Displacement cm3/rev	Max. Pressure		CODE	
		P1 bar	P3 bar	Left rotation	Right rotation
XV-1U/0.9	0,91	240	280	X 1 U 16 61 B B B A	X 1 U 16 62 B B B A
XV-1U/1.2	1,17	250	290	X 1 U 17 61 B B B A	X 1 U 17 62 B B B A
XV-1U/1.7	1,56	250	290	X 1 U 18 61 B B B A	X 1 U 18 62 B B B A
XV-1U/2.2	2,08	250	290	X 1 U 20 61 B B B A	X 1 U 20 62 B B B A
XV-1U/2.6	2,60	250	300	X 1 U 21 61 B B B A	X 1 U 21 62 B B B A
XV-1U/3.2	3,12	250	300	X 1 U 23 61 B B B A	X 1 U 23 62 B B B A
XV-1U/3.8	3,64	250	300	X 1 U 25 61 B B B A	X 1 U 25 62 B B B A
XV-1U/4.3	4,16	250	300	X 1 U 27 61 B B B A	X 1 U 27 62 B B B A
XV-1U/4.9	4,94	250	300	X 1 U 29 61 B B B A	X 1 U 29 62 B B B A
XV-1U/5.9	5,85	250	300	X 1 U 31 61 B B B A	X 1 U 31 62 B B B A
XV-1U/6.5	6,50	250	300	X 1 U 32 61 B B B A	X 1 U 32 62 B B B A
XV-1U/7.8	7,54	220	260	X 1 U 34 61 B B B A	X 1 U 34 62 B B B A
XV-1U/9.8	9,88	190	230	X 1 U 36 61 B B B A	X 1 U 36 62 B B B A

P1) Max. working pressure - P3) Max. peak pressure

For heavy-duty applications, it is recommended to check the admissible torque of the shaft

Dimensions table

TYPE	Weight kg	A	B	C	D	D
		mm	mm	mm	IN	OUT
XV-1U/0.9	1,000	82,6	41,8	70,6	3/8" BSPP	3/8" BSPP
XV-1U/1.2	1,020	83,5	42,3	71,5	3/8" BSPP	3/8" BSPP
XV-1U/1.7	1,060	85,0	43,0	73,0	3/8" BSPP	3/8" BSPP
XV-1U/2.2	1,080	87,0	44,0	75,0	3/8" BSPP	3/8" BSPP
XV-1U/2.6	1,110	89,0	45,0	77,0	3/8" BSPP	3/8" BSPP
XV-1U/3.2	1,140	91,0	46,0	79,0	3/8" BSPP	3/8" BSPP
XV-1U/3.8	1,170	93,0	47,0	81,0	3/8" BSPP	3/8" BSPP
XV-1U/4.3	1,220	95,0	48,0	83,0	3/8" BSPP	3/8" BSPP
XV-1U/4.9	1,250	98,0	49,5	86,0	3/8" BSPP	3/8" BSPP
XV-1U/5.9	1,310	101,5	51,3	89,5	3/8" BSPP	3/8" BSPP
XV-1U/6.5	1,350	105,0	52,5	93,0	3/8" BSPP	3/8" BSPP
XV-1U/7.8	1,410	108,0	54,5	96,0	3/8" BSPP	3/8" BSPP
XV-1U/9.8	1,550	117,0	59,0	105,0	3/8" BSPP	3/8" BSPP

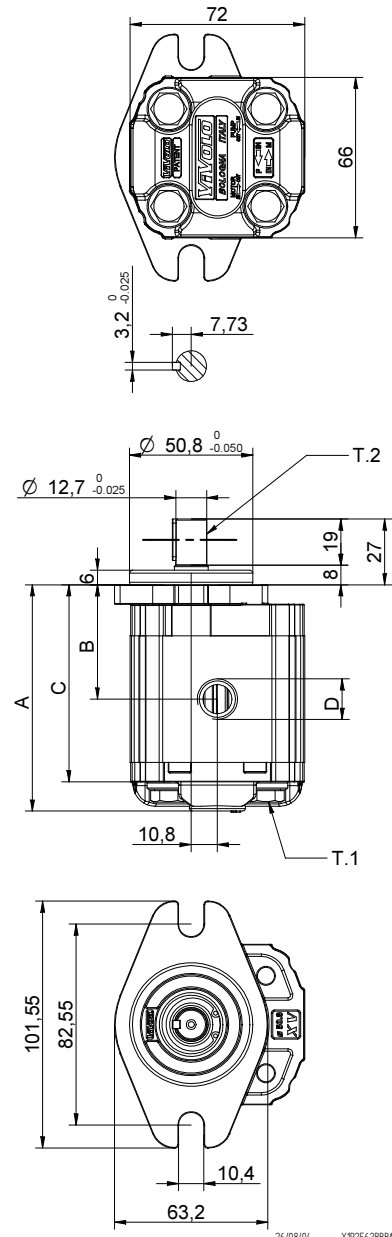

T.1 = 24.5÷29.4 [Nm] - screw tightening torque M8

T.2 = 32.8 [Nm] - admissible shaft torque (N.B. When choosing a shaft, always check the admissible torque).

# Table of variations

**XV-1U**

## ø50.8 FLANGE "SAE AA"

ø50.8 FLANGE "SAE AA"		Shaft		Cover	
Left rotation	Right rotation			Left rotation	Right rotation
		CI001 - Parallel T.2 = 25.8 [Nm] 	CI002 - Parallel T.2 = 32.8 [Nm] SAE 		
61	62	A	B	A	A
		CF003 - Milled shank T.2 = 25.9 [Nm] SAE 	CO002 - Tapered T.2 = 119.8 [Nm] 		
		E	G	B	B
		SAE 	SCF05 - Splined T.2 = 32.2 [Nm] SAE J 498 9T 20/40 DP 		
		I	K	C	C
		CO002+HK - Tapered T.2 = 119.8 [Nm] HK 14-12 	CI001+HK - Parallel T.2 = 25.8 [Nm] HK 14-12 		
		O	P	D	D
				N	N
				O	O

Displacement	
TYPE	CODE
XV-1U/0.9	16
XV-1U/1.2	17
XV-1U/1.7	18
XV-1U/2.2	20
XV-1U/2.6	21
XV-1U/3.2	23
XV-1U/3.8	25
XV-1U/4.3	27
XV-1U/4.9	29
XV-1U/5.9	31
XV-1U/6.5	32
XV-1U/7.8	34
XV-1U/9.8	36

Standard bodies							
Displacement cm3/rev	Standard threads						
	0.9	I - I	B - B	J - J	B - Z	Z - Z	G - F
1.2	I - I	B - B	J - J	B - Z	Z - Z	G - F	
1.7	I - I	B - B	J - J	B - Z	Z - Z	G - F	
2.2	I - I	B - B	J - J	B - Z	Z - Z	G - F	
2.6	I - I	B - B	J - J	B - Z	Z - Z	G - F	
3.2	I - I	B - B	J - J	B - Z	Z - Z	G - F	
3.8	I - I	B - B	J - J	B - Z	Z - Z	G - F	
4.3	I - I	B - B	J - J	B - Z	Z - Z	G - F	
4.9	I - I	B - B	J - J	B - Z	Z - Z	G - F	
5.9	I - I	B - B	J - J	B - Z	Z - Z	G - F	
6.5	I - I	B - B	J - J	B - Z	Z - Z	G - F	
7.8	I - I	B - B	J - J	B - Z	Z - Z	G - F	
9.8	I - I	B - B	J - J	B - Z	Z - Z	G - F	

Table showing standard flange and thread combinations available in stock

Body (threads/flanges)							
	A		B		C		D
	E		F		G		
	H		I		J		Z

# unidirectional motor - series XV

# XV-2U

STANDARD EUROPEAN MOTOR  
 ø36.5 FLANGE - TAPER SHAFT

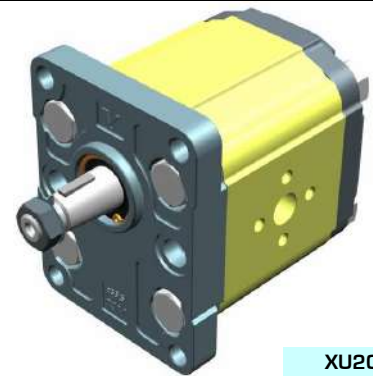

XU201

**X 2 U 51 02 E P O A**

Series	X	series XV
Group	2	group 2
Category	U	unidirectional motor
Displacement	51	17
Flange	02	Ø36.5 STANDARD EUROPEAN right rotation
Shaft	E	CO001 - Tapered 1:8 - ø17.4 - M12x1.5 - key thk.4
Body	IN	inlet - Ø40 Ø20 M8
	OUT	outlet - Ø30 Ø13.5 M6
Cover	A	standard

Technical data table						
TYPE	Displacement cm3/rev	Max. Pressure		CODE		
		P1 bar	P3 bar	Left rotation	Right rotation	
XV-2U/04	4,20	260	300	X 2 U 41 01 E O O A	X 2 U 41 02 E O O A	
XV-2U/06	6,00	260	300	X 2 U 43 01 E O O A	X 2 U 43 02 E O O A	
XV-2U/09	8,40	260	300	X 2 U 45 01 E O O A	X 2 U 45 02 E O O A	
XV-2U/11	10,80	260	300	X 2 U 47 01 E O O A	X 2 U 47 02 E O O A	
XV-2U/14	14,40	250	290	X 2 U 49 01 E P O A	X 2 U 49 02 E P O A	
XV-2U/17	16,80	230	270	X 2 U 51 01 E P O A	X 2 U 51 02 E P O A	
XV-2U/19	19,20	210	250	X 2 U 53 01 E P O A	X 2 U 53 02 E P O A	
XV-2U/22	22,80	200	240	X 2 U 55 01 E P O A	X 2 U 55 02 E P O A	
XV-2U/26	26,20	170	210	X 2 U 57 01 E Q P A	X 2 U 57 02 E Q P A	
XV-2U/30	30,00	160	200	X 2 U 59 01 E Q P A	X 2 U 59 02 E Q P A	
XV-2U/34	34,20	150	190	X 2 U 61 01 E Q P A	X 2 U 61 02 E Q P A	
XV-2U/40	39,60	140	180	X 2 U 63 01 E Q P A	X 2 U 63 02 E Q P A	

P1) Max. working pressure - P3) Max. peak pressure

For heavy-duty applications, it is recommended to check the admissible torque of the shaft

Dimensions table										
TYPE	Weight kg	A	B	C	D	E	F	D	E	F
		mm	mm	mm	IN			OUT		
XV-2U/04	2,200	87,2	41,7	77,2	ø13,5	30	M6x1	ø13,5	30	M6x1
XV-2U/06	2,300	90,2	43,2	80,2	ø13,5	30	M6x1	ø13,5	30	M6x1
XV-2U/09	2,400	94,2	45,2	84,2	ø13,5	30	M6x1	ø13,5	30	M6x1
XV-2U/11	2,500	98,2	47,2	88,2	ø13,5	30	M6x1	ø13,5	30	M6x1
XV-2U/14	2,700	104,2	50,2	94,2	ø13,5	30	M6x1	ø20	40	M8X1,25
XV-2U/17	2,800	108,2	52,2	98,2	ø13,5	30	M6x1	ø20	40	M8X1,25
XV-2U/19	2,900	112,2	54,2	102,2	ø13,5	30	M6x1	ø20	40	M8X1,25
XV-2U/22	3,050	118,2	57,2	108,2	ø13,5	30	M6x1	ø20	40	M8X1,25
XV-2U/26	3,150	122,2	59,2	112,2	ø20	40	M8X1,25	ø23,5	40	M8X1,25
XV-2U/30	3,400	130,2	63,2	120,2	ø20	40	M8X1,25	ø23,5	40	M8X1,25
XV-2U/34	3,600	137,2	66,7	127,2	ø20	40	M8X1,25	ø23,5	40	M8X1,25
XV-2U/40	3,800	146,2	71,2	136,2	ø20	40	M8X1,25	ø23,5	40	M8X1,25

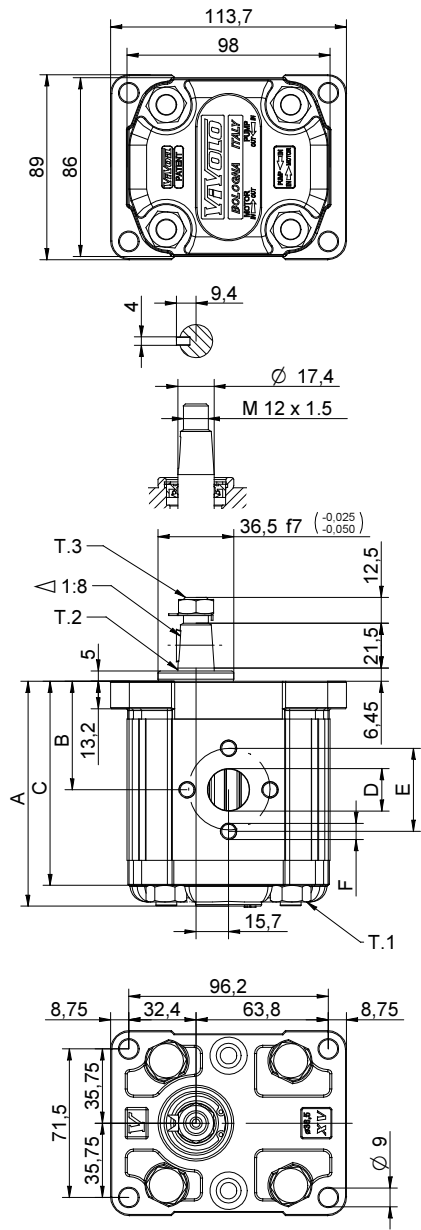

T.1 = 54÷58.9 [Nm] - screw tightening torque M10

T.3 = 40 [Nm] - torque wrench setting 19

T.2 = 233.2 [Nm] - admissible shaft torque (N.B. When choosing a shaft, always check the admissible torque).

# Table of variations

# XV-2U

## ø36.5 FLANGE

ø36.5 FLANGE				Shaft				Cover			
Left rotation		Right rotation						Left rotation		Right rotation	
	01		02	CI001 - Parallel T.2 = 44.1 [Nm]	A	CI002 - Parallel T.2 = 67.5 [Nm]	B				A
	03		04	CO001 - Tapered T.2 = 233.2 [Nm]	E	CO002 - Tapered T.2 = 233.2 [Nm]	F				B
	05		06	SCF02 - Splined T.2 = 86.1 [Nm]	G	SCF03 - Splined T.2 = 86.1 [Nm]	H				C
	07		08	SCF04 - Splined T.2 = 67.1 [Nm]	I	SCF01 - Splined T.2 = 86.2 [Nm]	L				D

Displacement	
TYPE	CODE
XV-2U/04	41
XV-2U/06	43
XV-2U/09	45
XV-2U/11	47
XV-2U/14	49
XV-2U/17	51
XV-2U/19	53
XV-2U/22	55
XV-2U/26	57
XV-2U/30	59
XV-2U/34	61
XV-2U/40	63

Standard bodies						
Displacement cm <sup>3</sup> /rev	Standard threads					
	4	O - O	S - R	B - B	L - M	Z - Z
6	O - O	S - R	B - B	L - M	Z - Z	Z - Z
9	O - O	S - R	B - B	L - M	Z - Z	Z - Z
11	O - O	S - R	B - B	L - M	Z - Z	Z - Z
14	P - O	S - R	C - B	L - M	Z - Z	Z - Z
17	P - O	S - R	C - B	L - M	Z - Z	Z - Z
19	P - O	S - R	C - B	L - M	Z - Z	Z - Z
22	P - O	S - R	C - B	L - M	Z - Z	Z - Z
26	Q - P	S - R	D - C	L - M	Z - Z	Z - Z
30	Q - P	S - S	D - C	L - M	Z - Z	Z - Z
34	Q - P	S - S	D - C	L - M	Z - Z	Z - Z
40	Q - P	S - S	D - C	L - M	Z - Z	Z - Z

Table showing standard flange and thread combinations available in stock

			N
Internal drainage			
			O
External drainage			

Body (threads/flanges)													
	A		B		C		D		E		F		G
	H		I		L		M		N		O		P
	Q		R		S		T		U		V		Z

# unidirectional motor - series XV

# XV-2U

STANDARD EUROPEAN MOTOR  
ø36.5 FLANGE - TAPER SHAFT

**X 2 U 51 02 E C B A**

Series	X	series XV
Group	2	group 2
Category	U	unidirectional motor
Displacement	51	17
Flange	02	Ø36.5 STANDARD EUROPEAN right rotation
Shaft	E	CO001 - Tapered 1:8 - ø17.4 - M12x1.5 - key thk.4
Body	IN	inlet - 3/4" GAS
	OUT	outlet - 1/2" GAS
Cover	A	standard



XU207

Technical data table

TYPE	Displacement cm3/rev	Max. Pressure		CODE	
		P1 bar	P3 bar	Left rotation	Right rotation
XV-2U/04	4,20	260	300	X 2 U 41 01 E B B A	X 2 U 41 02 E B B A
XV-2U/06	6,00	260	300	X 2 U 43 01 E B B A	X 2 U 43 02 E B B A
XV-2U/09	8,40	260	300	X 2 U 45 01 E B B A	X 2 U 45 02 E B B A
XV-2U/11	10,80	260	300	X 2 U 47 01 E B B A	X 2 U 47 02 E B B A
XV-2U/14	14,40	250	290	X 2 U 49 01 E C B A	X 2 U 49 02 E C B A
XV-2U/17	16,80	230	270	X 2 U 51 01 E C B A	X 2 U 51 02 E C B A
XV-2U/19	19,20	210	250	X 2 U 53 01 E C B A	X 2 U 53 02 E C B A
XV-2U/22	22,80	200	240	X 2 U 55 01 E C B A	X 2 U 55 02 E C B A
XV-2U/26	26,20	170	210	X 2 U 57 01 E D C A	X 2 U 57 02 E D C A
XV-2U/30	30,00	160	200	X 2 U 59 01 E D C A	X 2 U 59 02 E D C A
XV-2U/34	34,20	150	190	X 2 U 61 01 E D C A	X 2 U 61 02 E D C A
XV-2U/40	39,60	140	180	X 2 U 63 01 E D C A	X 2 U 63 02 E D C A

P1) Max. working pressure - P3) Max. peak pressure

For heavy-duty applications, it is recommended to check the admissible torque of the shaft

Dimensions table

TYPE	Weight kg	A	B	C	D	D
		mm	mm	mm	IN	OUT
XV-2U/04	2,200	87,2	41,7	77,2	1/2" BSPP	1/2" BSPP
XV-2U/06	2,300	90,2	43,2	80,2	1/2" BSPP	1/2" BSPP
XV-2U/09	2,400	94,2	45,2	84,2	1/2" BSPP	1/2" BSPP
XV-2U/11	2,500	98,2	47,2	88,2	1/2" BSPP	1/2" BSPP
XV-2U/14	2,700	104,2	50,2	94,2	3/4" BSPP	1/2" BSPP
XV-2U/17	2,800	108,2	52,2	98,2	3/4" BSPP	1/2" BSPP
XV-2U/19	2,900	112,2	54,2	102,2	3/4" BSPP	1/2" BSPP
XV-2U/22	3,050	118,2	57,2	108,2	3/4" BSPP	1/2" BSPP
XV-2U/26	3,150	122,2	59,2	112,2	1" BSPP	3/4" BSPP
XV-2U/30	3,400	130,2	63,2	120,2	1" BSPP	3/4" BSPP
XV-2U/34	3,600	137,2	66,7	127,2	1" BSPP	3/4" BSPP
XV-2U/40	3,800	146,2	71,2	136,2	1" BSPP	3/4" BSPP

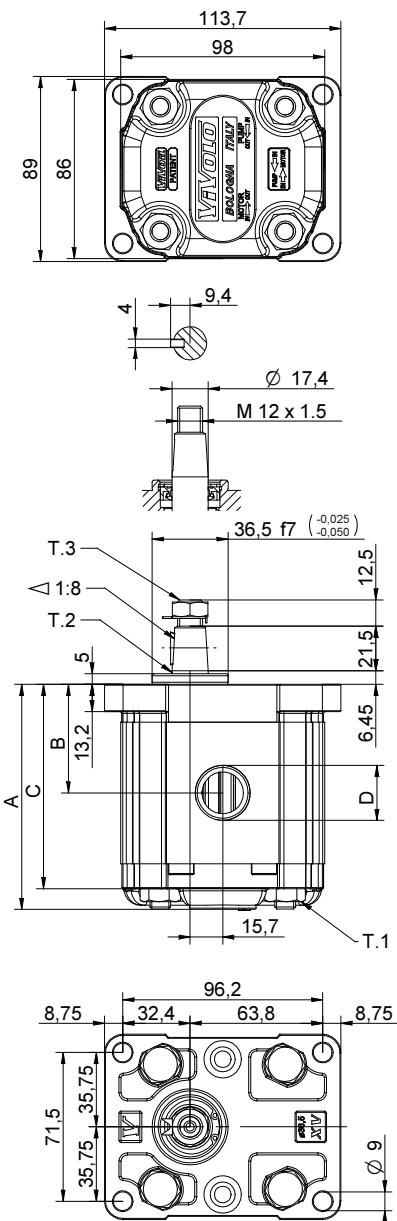

26/08/04 XZPS102E2BA.dft

T.1 = 54÷58.9 [Nm] - screw tightening torque M10

T.3 = 40 [Nm] - torque wrench setting 19

T.2 = 233.2 [Nm] - admissible shaft torque (N.B. When choosing a shaft, always check the admissible torque).

# Table of variations

# XV-2U

## ø36.5 FLANGE

ø36.5 FLANGE				Shaft				Cover			
Left rotation		Right rotation						Left rotation		Right rotation	
	01		02	CI001 - Parallel T.2 = 44.1 [Nm]	A	CI002 - Parallel T.2 = 67.5 [Nm]	B				A
	03		04	CO001 - Tapered T.2 = 233.2 [Nm]	E	CO002 - Tapered T.2 = 233.2 [Nm]	F				B
	05		06	SCF02 - Splined T.2 = 86.1 [Nm]	G	SCF03 - Splined T.2 = 86.1 [Nm]	H				C
	07		08	SCF04 - Splined T.2 = 67.1 [Nm]	I	SCF01 - Splined T.2 = 86.2 [Nm]	L				D
											N
											O

Displacement	
TYPE	CODE
XV-2U/04	41
XV-2U/06	43
XV-2U/09	45
XV-2U/11	47
XV-2U/14	49
XV-2U/17	51
XV-2U/19	53
XV-2U/22	55
XV-2U/26	57
XV-2U/30	59
XV-2U/34	61
XV-2U/40	63

Standard bodies						
Displacement cm <sup>3</sup> /rev	Standard threads					
	4	O - O	S - R	B - B	L - M	Z - Z
6	O - O	S - R	B - B	L - M	Z - Z	Z - Z
9	O - O	S - R	B - B	L - M	Z - Z	Z - Z
11	O - O	S - R	B - B	L - M	Z - Z	Z - Z
14	P - O	S - R	C - B	L - M	Z - Z	Z - Z
17	P - O	S - R	C - B	L - M	Z - Z	Z - Z
19	P - O	S - R	C - B	L - M	Z - Z	Z - Z
22	P - O	S - R	C - B	L - M	Z - Z	Z - Z
26	Q - P	S - R	D - C	L - M	Z - Z	Z - Z
30	Q - P	S - S	D - C	L - M	Z - Z	Z - Z
34	Q - P	S - S	D - C	L - M	Z - Z	Z - Z
40	Q - P	S - S	D - C	L - M	Z - Z	Z - Z

Table showing standard flange and thread combinations available in stock

Body (threads/flanges)													
	A		B		C		D		E		F		G
	H		I		L		M		N		O		P
	Q		R		S		T		U		V		Z

# unidirectional motor - series XV

# XV-2U

**BH TYPE MOTOR**  
**ø50 BODY-SHAPED FLANGE - TAPER SHAFT**

**X 2 U 51 12 F S R A**

Series	X	series XV
Group	2	group 2
Category	U	unidirectional motor
Displacement	51	17
Flange	12	ø50 BH GERMAN STANDARDIZED right rotation
Shaft	F	CO002 - Tapered 1:5 - ø17.4 - M12x1.5 - key thk.3
Body	IN	inlet - Ø40 a 45° Ø20 M6
	OUT	outlet - Ø35 a 45° Ø15 M6
Cover	A	standard

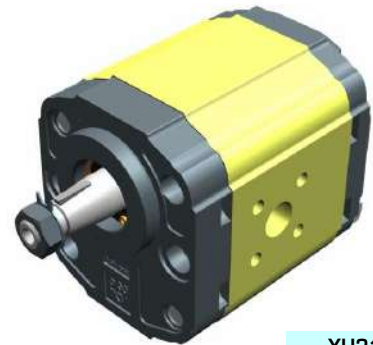

**XU210**

Technical data table						
TYPE	Displacement cm3/rev	Max. Pressure		CODE		
		P1 bar	P3 bar	Left rotation	Right rotation	
XV-2U/04	4,20	260	300	X 2 U 41 11 F S R A	X 2 U 41 12 F S R A	
XV-2U/06	6,00	260	300	X 2 U 43 11 F S R A	X 2 U 43 12 F S R A	
XV-2U/09	8,40	260	300	X 2 U 45 11 F S R A	X 2 U 45 12 F S R A	
XV-2U/11	10,80	260	300	X 2 U 47 11 F S R A	X 2 U 47 12 F S R A	
XV-2U/14	14,40	250	290	X 2 U 49 11 F S R A	X 2 U 49 12 F S R A	
XV-2U/17	16,80	230	270	X 2 U 51 11 F S R A	X 2 U 51 12 F S R A	
XV-2U/19	19,20	210	250	X 2 U 53 11 F S R A	X 2 U 53 12 F S R A	
XV-2U/22	22,80	200	240	X 2 U 55 11 F S R A	X 2 U 55 12 F S R A	
XV-2U/26	26,20	170	210	X 2 U 57 11 F S R A	X 2 U 57 12 F S R A	
XV-2U/30	30,00	160	200	X 2 U 59 11 F S S A	X 2 U 59 12 F S S A	
XV-2U/34	34,20	150	190	X 2 U 61 11 F S S A	X 2 U 61 12 F S S A	
XV-2U/40	39,60	140	180	X 2 U 63 11 F S S A	X 2 U 63 12 F S S A	

P1) Max. working pressure - P3) Max. peak pressure

For heavy-duty applications, it is recommended to check the admissible torque of the shaft

Dimensions table										
TYPE	Weight kg	A	B	C	D	E	F	D	E	F
		mm	mm	mm	IN			OUT		
XV-2U/04	2,100	87,2	38,6	77,2	ø15	35	M6x1	ø20	40	M6x1
XV-2U/06	2,200	90,2	38,6	80,2	ø15	35	M6x1	ø20	40	M6x2
XV-2U/09	2,300	94,2	40,6	84,2	ø15	35	M6x1	ø20	40	M6x3
XV-2U/11	2,400	98,2	45,0	88,2	ø15	35	M6x1	ø20	40	M6x4
XV-2U/14	2,600	104,2	45,0	94,2	ø15	35	M6x1	ø20	40	M6x5
XV-2U/17	2,700	108,2	45,0	98,2	ø15	35	M6x1	ø20	40	M6x6
XV-2U/19	2,800	112,2	45,0	102,2	ø15	35	M6x1	ø20	40	M6x7
XV-2U/22	2,950	118,2	52,5	108,2	ø15	35	M6x1	ø20	40	M6x8
XV-2U/26	3,050	122,2	52,5	112,2	ø15	35	M6x1	ø20	40	M6x9
XV-2U/30	3,300	130,2	60,7	120,2	ø20	40	M6x1	ø20	40	M6x10
XV-2U/34	3,500	137,2	60,7	127,2	ø20	40	M6x1	ø20	40	M6x11
XV-2U/40	3,700	146,2	60,7	136,2	ø20	40	M6x1	ø20	40	M6x12

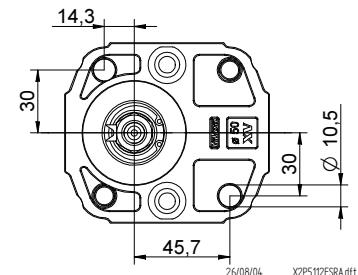
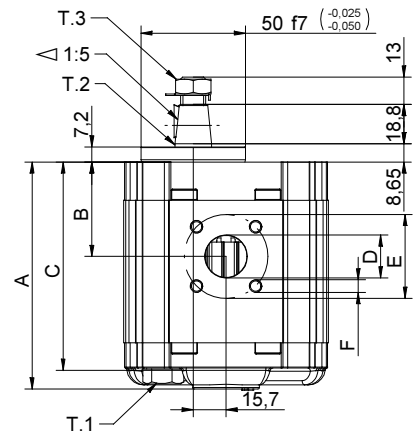
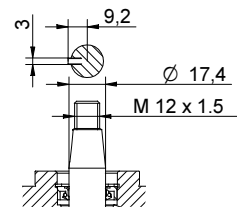
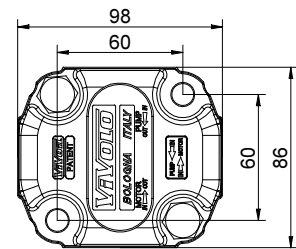

T.1 = 54÷58.9 [Nm] - screw tightening torque M10

T.3 = 40 [Nm] - torque wrench setting 19

T.2 = 233.2 [Nm] - admissible shaft torque (N.B. When choosing a shaft, always check the admissible torque).

# Table of variations

**XV-2U**

## ø50 "BH" Body-Shaped FLANGE

ø50 "BH" Body-Shaped FLANGE				Shaft				Cover			
Left rotation		Right rotation		Left rotation		Right rotation		Left rotation		Right rotation	
	11		12	CI001 - Parallel T.2 = 44.1 [Nm] 	A	CI002 - Parallel T.2 = 67.5 [Nm] 	B				A
	13		14	CO001 - Tapered T.2 = 233.2 [Nm] 	E	CO002 - Tapered T.2 = 233.2 [Nm] 	F				B
	15		16	SCF03 - Splined T.2 = 86.1 [Nm] m=1.6 Z=9 DIN 5482 - 17x14 	H						C
	17		18								D

Displacement	
TYPE	CODE
XV-2U/04	41
XV-2U/06	43
XV-2U/09	45
XV-2U/11	47
XV-2U/14	49
XV-2U/17	51
XV-2U/19	53
XV-2U/22	55
XV-2U/26	57
XV-2U/30	59
XV-2U/34	61
XV-2U/40	63

Displacement cm3/rev	Standard bodies					
	Standard threads					
4	O - O	S - R	B - B	L - M	Z - Z	Z - Z
6	O - O	S - R	B - B	L - M	Z - Z	Z - Z
9	O - O	S - R	B - B	L - M	Z - Z	Z - Z
11	O - O	S - R	B - B	L - M	Z - Z	Z - Z
14	P - O	S - R	C - B	L - M	Z - Z	Z - Z
17	P - O	S - R	C - B	L - M	Z - Z	Z - Z
19	P - O	S - R	C - B	L - M	Z - Z	Z - Z
22	P - O	S - R	C - B	L - M	Z - Z	Z - Z
26	Q - P	S - R	D - C	L - M	Z - Z	Z - Z
30	Q - P	S - S	D - C	L - M	Z - Z	Z - Z
34	Q - P	S - S	D - C	L - M	Z - Z	Z - Z
40	Q - P	S - S	D - C	L - M	Z - Z	Z - Z

Table showing standard flange and thread combinations available in stock

				N
Internal drainage				
				O
External drainage				

Body (threads/flanges)													
	A		B		C		D		E		F		G
	H		I		L		M		N		O		P
	Q		R		S		T		U		V	Closed Body Z	

# unidirectional motor - series XV

# XV-2U

HY TYPE MOTOR  
 ø50 BODY-SHAPED FLANGE - TAPER SHAFT

**X 2 U 51 22 F S R A**

Series	X	series XV
Group	2	group 2
Category	U	unidirectional motor
Displacement	51	17
Flange	22	Ø50 HY GERMAN STANDARDIZED right rotation
Shaft	F	CO002 - Tapered 1:5 - ø17.4 - M12x1.5 - key thk.3
Body	IN	inlet - Ø40 a 45° Ø20 M6
	OUT	outlet - Ø35 a 45° Ø15 M6
Cover	A	standard

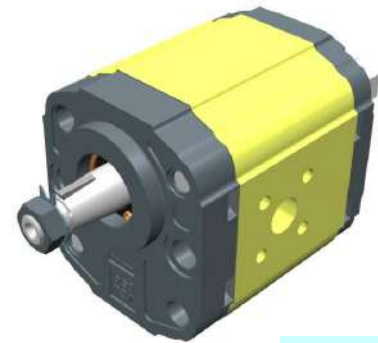

XU213

Technical data table

TYPE	Displacement cm3/rev	Max. Pressure		CODE	
		P1 bar	P3 bar	Left rotation	Right rotation
XV-2U/04	4,20	260	300	X 2 U 41 21 F S R A	X 2 U 41 22 F S R A
XV-2U/06	6,00	260	300	X 2 U 43 21 F S R A	X 2 U 43 22 F S R A
XV-2U/09	8,40	260	300	X 2 U 45 21 F S R A	X 2 U 45 22 F S R A
XV-2U/11	10,80	260	300	X 2 U 47 21 F S R A	X 2 U 47 22 F S R A
XV-2U/14	14,40	250	290	X 2 U 49 21 F S R A	X 2 U 49 22 F S R A
XV-2U/17	16,80	230	270	X 2 U 51 21 F S R A	X 2 U 51 22 F S R A
XV-2U/19	19,20	210	250	X 2 U 53 21 F S R A	X 2 U 53 22 F S R A
XV-2U/22	22,80	200	240	X 2 U 55 21 F S R A	X 2 U 55 22 F S R A
XV-2U/26	26,20	170	210	X 2 U 57 21 F S R A	X 2 U 57 22 F S R A
XV-2U/30	30,00	160	200	X 2 U 59 21 F S S A	X 2 U 59 22 F S S A
XV-2U/34	34,20	150	190	X 2 U 61 21 F S S A	X 2 U 61 22 F S S A
XV-2U/40	39,60	140	180	X 2 U 63 21 F S S A	X 2 U 63 22 F S S A

P1) Max. working pressure - P3) Max. peak pressure

For heavy-duty applications, it is recommended to check the admissible torque of the shaft

Dimensions table

TYPE	Weight kg	A	B	C	D	E	F	D	E	F
		mm	mm	mm	IN			OUT		
XV-2U/04	2,100	87,2	38,6	77,2	ø15	35	M6x1	ø20	40	M6x1
XV-2U/06	2,200	90,2	38,6	80,2	ø15	35	M6x1	ø20	40	M6x2
XV-2U/09	2,300	94,2	40,6	84,2	ø15	35	M6x1	ø20	40	M6x3
XV-2U/11	2,400	98,2	45,0	88,2	ø15	35	M6x1	ø20	40	M6x4
XV-2U/14	2,600	104,2	45,0	94,2	ø15	35	M6x1	ø20	40	M6x5
XV-2U/17	2,700	108,2	45,0	98,2	ø15	35	M6x1	ø20	40	M6x6
XV-2U/19	2,800	112,2	45,0	102,2	ø15	35	M6x1	ø20	40	M6x7
XV-2U/22	2,950	118,2	52,5	108,2	ø15	35	M6x1	ø20	40	M6x8
XV-2U/26	3,050	122,2	52,5	112,2	ø15	35	M6x1	ø20	40	M6x9
XV-2U/30	3,300	130,2	60,7	120,2	ø20	40	M6x1	ø20	40	M6x10
XV-2U/34	3,500	137,2	60,7	127,2	ø20	40	M6x1	ø20	40	M6x11
XV-2U/40	3,700	146,2	60,7	136,2	ø20	40	M6x1	ø20	40	M6x12

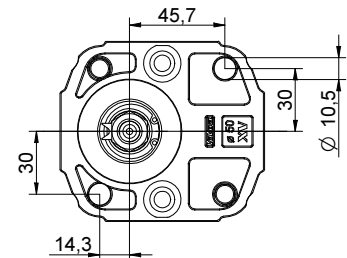
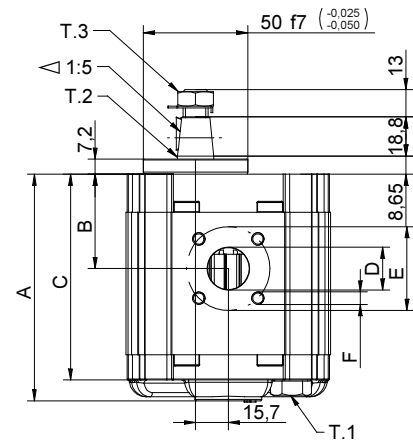
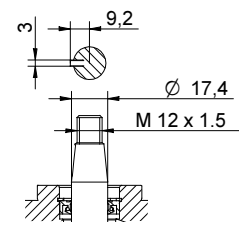
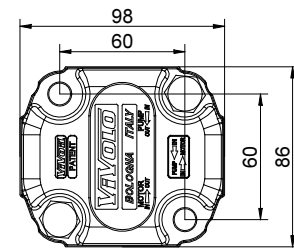

26/08/04 XZPS12ZF58A.dft

T.1 = 54÷58.9 [Nm] - screw tightening torque M10

T.3 = 40 [Nm] - torque wrench setting 19

T.2 = 233.2 [Nm] - admissible shaft torque (N.B. When choosing a shaft, always check the admissible torque).

# Table of variations

**XV-2U**

## ø50 "HY" Body-Shaped FLANGE

ø50 "HY" Body-Shaped FLANGE				Shaft				Cover			
Left rotation		Right rotation		Left rotation		Right rotation		Left rotation		Right rotation	
	21		22	CI001 - Parallel T.2 = 44.1 [Nm] 	A	CI002 - Parallel T.2 = 67.5 [Nm] 	B				A
	23		24	CO001 - Tapered T.2 = 233.2 [Nm] 	E	CO002 - Tapered T.2 = 233.2 [Nm] 	F				B
	25		26	SCF03 - Splined T.2 = 86.1 [Nm] m=1.6 Z=9 DIN 5482 - 17x14 	H						C
	27		28								D

Displacement	
TYPE	CODE
XV-2U/04	41
XV-2U/06	43
XV-2U/09	45
XV-2U/11	47
XV-2U/14	49
XV-2U/17	51
XV-2U/19	53
XV-2U/22	55
XV-2U/26	57
XV-2U/30	59
XV-2U/34	61
XV-2U/40	63

Displacement cm3/rev	Standard bodies					
	Standard threads					
4	O - O	S - R	B - B	L - M	Z - Z	
6	O - O	S - R	B - B	L - M	Z - Z	
9	O - O	S - R	B - B	L - M	Z - Z	
11	O - O	S - R	B - B	L - M	Z - Z	
14	P - O	S - R	C - B	L - M	Z - Z	
17	P - O	S - R	C - B	L - M	Z - Z	
19	P - O	S - R	C - B	L - M	Z - Z	
22	P - O	S - R	C - B	L - M	Z - Z	
26	Q - P	S - R	D - C	L - M	Z - Z	
30	Q - P	S - S	D - C	L - M	Z - Z	
34	Q - P	S - S	D - C	L - M	Z - Z	
40	Q - P	S - S	D - C	L - M	Z - Z	

Table showing standard flange and thread combinations available in stock

			N
			O

Body (threads/flanges)													
	A		B		C		D		E		F		G
	H		I		L		M		N		O		P
	Q		R		S		T		U		V	<b>Closed Body</b>	Z

# unidirectional motor - series XV

# XV-2U

STANDARD GERMAN "BH" TYPE MOTOR  
 ø52 BODY-SHAPED FLANGE - MILLED SHANK

**X 2 U 51 32 C S R A**

Series	X	series XV
Group	2	group 2
Category	U	unidirectional motor
Displacement	51	17
Flange	32	Ø52 GERMAN STANDARDIZED right rotation (with OR)
Shaft	C	CF001 - Milled shank ø15 - thk.8 ("BH" Standard German)
Body	IN	S inlet - Ø40 a 45° Ø20 M6
	OUT	R outlet - Ø35 a 45° Ø15 M6
Cover	A	standard

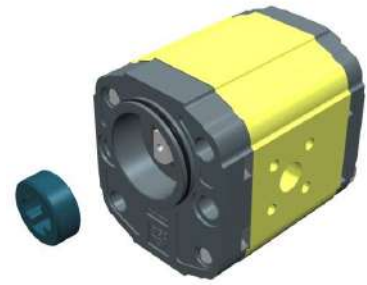

XU216

Technical data table

TYPE	Displacement cm3/rev	Max. Pressure		CODE	
		P1 bar	P3 bar	Left rotation	Right rotation
XV-2U/04	4,20	260	300	X 2 U 41 31 C S R A	X 2 U 41 32 C S R A
XV-2U/06	6,00	260	300	X 2 U 43 31 C S R A	X 2 U 43 32 C S R A
XV-2U/09	8,40	260	300	X 2 U 45 31 C S R A	X 2 U 45 32 C S R A
XV-2U/11	10,80	260	300	X 2 U 47 31 C S R A	X 2 U 47 32 C S R A
XV-2U/14	14,40	250	290	X 2 U 49 31 C S R A	X 2 U 49 32 C S R A
XV-2U/17	16,80	230	270	X 2 U 51 31 C S R A	X 2 U 51 32 C S R A
XV-2U/19	19,20	210	250	X 2 U 53 31 C S R A	X 2 U 53 32 C S R A
XV-2U/22	22,80	200	240	X 2 U 55 31 C S R A	X 2 U 55 32 C S R A
XV-2U/26	26,20	170	210	X 2 U 57 31 C S R A	X 2 U 57 32 C S R A
XV-2U/30	30,00	160	200	X 2 U 59 31 C S S A	X 2 U 59 32 C S S A
XV-2U/34	34,20	150	190	X 2 U 61 31 C S S A	X 2 U 61 32 C S S A
XV-2U/40	39,60	140	180	X 2 U 63 31 C S S A	X 2 U 63 32 C S S A

P1) Max. working pressure - P3) Max. peak pressure

For heavy-duty applications, it is recommended to check the admissible torque of the shaft

Dimensions table

TYPE	Weight kg	A	B	C	D	E	F	D	E	F
		mm	mm	mm	IN			OUT		
XV-2U/04	2,100	87,2	38,6	77,2	ø15	35	M6x1	ø20	40	M6x1
XV-2U/06	2,200	90,2	38,6	80,2	ø15	35	M6x1	ø20	40	M6x2
XV-2U/09	2,300	94,2	40,6	84,2	ø15	35	M6x1	ø20	40	M6x3
XV-2U/11	2,400	98,2	45,0	88,2	ø15	35	M6x1	ø20	40	M6x4
XV-2U/14	2,600	104,2	45,0	94,2	ø15	35	M6x1	ø20	40	M6x5
XV-2U/17	2,700	108,2	45,0	98,2	ø15	35	M6x1	ø20	40	M6x6
XV-2U/19	2,800	112,2	45,0	102,2	ø15	35	M6x1	ø20	40	M6x7
XV-2U/22	2,950	118,2	52,5	108,2	ø15	35	M6x1	ø20	40	M6x8
XV-2U/26	3,050	122,2	52,5	112,2	ø15	35	M6x1	ø20	40	M6x9
XV-2U/30	3,300	130,2	60,7	120,2	ø20	40	M6x1	ø20	40	M6x10
XV-2U/34	3,500	137,2	60,7	127,2	ø20	40	M6x1	ø20	40	M6x11
XV-2U/40	3,700	146,2	60,7	136,2	ø20	40	M6x1	ø20	40	M6x12

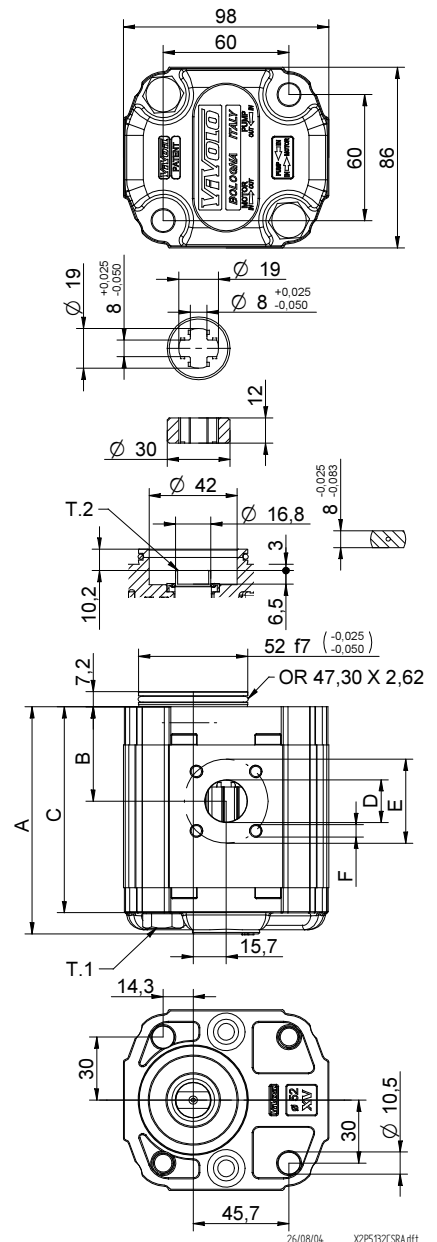

T.1 = 54÷58.9 [Nm] - screw tightening torque M10

T.2 = 60.5 [Nm] - admissible shaft torque (N.B. When choosing a shaft, always check the admissible torque).

# Table of variations

**XV-2U**

## Standard German ø52 "BH" FLANGE

Standard German ø52 "BH" FLANGE				Shaft				Cover			
Left rotation		Right rotation		CF001 - Milled shank		SCF05 - Splined		Left rotation		Right rotation	
	<b>31</b>		<b>32</b>	T.2 = 60.5 [Nm]		T.2 = 86.2 [Nm]				<b>A</b>	
	<b>33</b>		<b>34</b>	SCF01 - Splined						<b>B</b>	
	<b>35</b>		<b>36</b>							<b>C</b>	
	<b>37</b>		<b>38</b>							<b>D</b>	

Displacement	
TYPE	CODE
XV-2U/04	<b>41</b>
XV-2U/06	<b>43</b>
XV-2U/09	<b>45</b>
XV-2U/11	<b>47</b>
XV-2U/14	<b>49</b>
XV-2U/17	<b>51</b>
XV-2U/19	<b>53</b>
XV-2U/22	<b>55</b>
XV-2U/26	<b>57</b>
XV-2U/30	<b>59</b>
XV-2U/34	<b>61</b>
XV-2U/40	<b>63</b>

Standard bodies						
Displacement cm3/rev	Standard threads					
	4	O - O	S - R	B - B	L - M	Z - Z
6	O - O	S - R	B - B	L - M	Z - Z	
9	O - O	S - R	B - B	L - M	Z - Z	
11	O - O	S - R	B - B	L - M	Z - Z	
14	P - O	S - R	C - B	L - M	Z - Z	
17	P - O	S - R	C - B	L - M	Z - Z	
19	P - O	S - R	C - B	L - M	Z - Z	
22	P - O	S - R	C - B	L - M	Z - Z	
26	Q - P	S - R	D - C	L - M	Z - Z	
30	Q - P	S - S	D - C	L - M	Z - Z	
34	Q - P	S - S	D - C	L - M	Z - Z	
40	Q - P	S - S	D - C	L - M	Z - Z	

Table showing standard flange and thread combinations available in stock

		<b>N</b>	
Internal drainage			
		<b>O</b>	
External drainage			

Body (threads/flanges)													
	<b>A</b>		<b>B</b>		<b>C</b>		<b>D</b>		<b>E</b>		<b>F</b>		<b>G</b>
	<b>H</b>		<b>I</b>		<b>L</b>		<b>M</b>		<b>N</b>		<b>O</b>		<b>P</b>
	<b>Q</b>		<b>R</b>		<b>S</b>		<b>T</b>		<b>U</b>		<b>V</b>		<b>Z</b>

# unidirectional motor - series XV

# XV-2U

STANDARD GERMAN MOTOR  
ø80 FLANGE - TAPER SHAFT

**X 2 U 51 42 F S R A**

Series	X	series XV
Group	2	group 2
Category	U	unidirectional motor
Displacement	51	17
Flange	42	Ø80 GERMAN STANDARDIZED right rotation (with OR)
Shaft	F	CO002 - Tapered 1:5 - ø17.4 - M12x1.5 - key thk.3
Body	IN	inlet - Ø40 a 45° Ø20 M6
	OUT	outlet - Ø35 a 45° Ø15 M6
Cover	A	standard

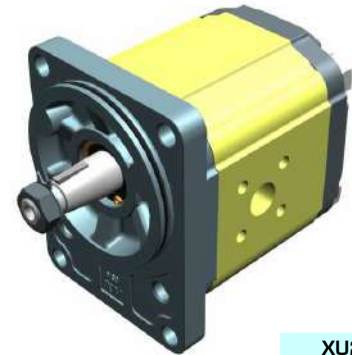

XU217

Technical data table

TYPE	Displacement cm3/rev	Max. Pressure		CODE	
		P1 bar	P3 bar	Left rotation	Right rotation
XV-2U/04	4,20	260	300	X 2 U 41 41 F S R A	X 2 U 41 42 F S R A
XV-2U/06	6,00	260	300	X 2 U 43 41 F S R A	X 2 U 43 42 F S R A
XV-2U/09	8,40	260	300	X 2 U 45 41 F S R A	X 2 U 45 42 F S R A
XV-2U/11	10,80	260	300	X 2 U 47 41 F S R A	X 2 U 47 42 F S R A
XV-2U/14	14,40	250	290	X 2 U 49 41 F S R A	X 2 U 49 42 F S R A
XV-2U/17	16,80	230	270	X 2 U 51 41 F S R A	X 2 U 51 42 F S R A
XV-2U/19	19,20	210	250	X 2 U 53 41 F S R A	X 2 U 53 42 F S R A
XV-2U/22	22,80	200	240	X 2 U 55 41 F S R A	X 2 U 55 42 F S R A
XV-2U/26	26,20	170	210	X 2 U 57 41 F S R A	X 2 U 57 42 F S R A
XV-2U/30	30,00	160	200	X 2 U 59 41 F S S A	X 2 U 59 42 F S S A
XV-2U/34	34,20	150	190	X 2 U 61 41 F S S A	X 2 U 61 42 F S S A
XV-2U/40	39,60	140	180	X 2 U 63 41 F S S A	X 2 U 63 42 F S S A

P1) Max. working pressure - P3) Max. peak pressure

For heavy-duty applications, it is recommended to check the admissible torque of the shaft

Dimensions table

TYPE	Weight kg	A	B	C	D	E	F	D	E	F
		mm	mm	mm	IN			OUT		
XV-2U/04	2,330	89,7	41,1	79,7	ø15	35	M6x1	ø20	40	M6x1
XV-2U/06	2,430	92,7	41,1	82,7	ø15	35	M6x1	ø20	40	M6x2
XV-2U/09	2,530	96,7	43,1	86,7	ø15	35	M6x1	ø20	40	M6x3
XV-2U/11	2,630	100,7	47,5	90,7	ø15	35	M6x1	ø20	40	M6x4
XV-2U/14	2,730	106,7	47,5	96,7	ø15	35	M6x1	ø20	40	M6x5
XV-2U/17	2,830	110,7	47,5	100,7	ø15	35	M6x1	ø20	40	M6x6
XV-2U/19	2,930	114,7	47,5	104,7	ø15	35	M6x1	ø20	40	M6x7
XV-2U/22	3,180	120,7	55,0	110,7	ø15	35	M6x1	ø20	40	M6x8
XV-2U/26	3,280	124,7	55,0	114,7	ø15	35	M6x1	ø20	40	M6x9
XV-2U/30	3,530	132,7	63,2	122,7	ø20	40	M6x1	ø20	40	M6x10
XV-2U/34	3,730	139,7	63,2	129,7	ø20	40	M6x1	ø20	40	M6x11
XV-2U/40	3,930	148,7	63,2	138,7	ø20	40	M6x1	ø20	40	M6x12

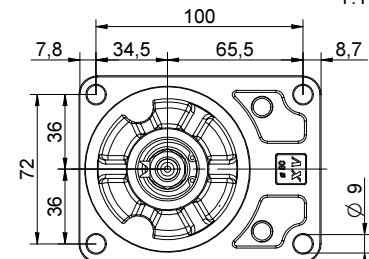
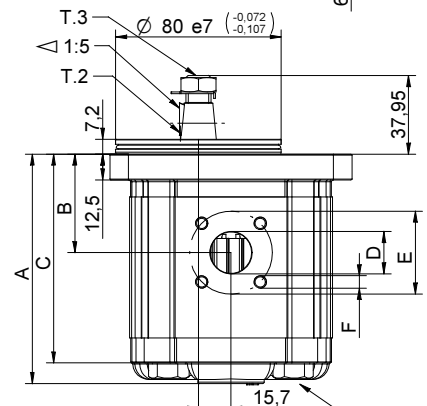
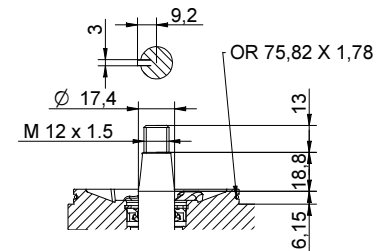
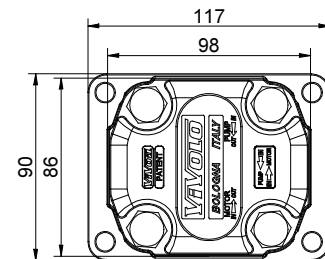

26/08/04 X2P5 1/2 F S R A diff

T.1 = 54÷58.9 [Nm] - screw tightening torque M10

T.3 = 40 [Nm] - torque wrench setting 19

T.2 = 233.2 [Nm] - admissible shaft torque (N.B. When choosing a shaft, always check the admissible torque).

# Table of variations

# XV-2U

## ø80 FLANGE

ø80 FLANGE		Shaft		Cover	
Left rotation	Right rotation			Left rotation	Right rotation
		CI001 - Parallel T.2 = 44.1 [Nm] 	CI002 - Parallel T.2 = 67.5 [Nm] 		
<b>41</b>	<b>42</b>	<b>A</b>	<b>B</b>	<b>A</b>	<b>A</b>
		CO001 - Tapered T.2 = 233.2 [Nm] 	CO002 - Tapered T.2 = 233.2 [Nm] 		
		<b>E</b>	<b>F</b>	<b>B</b>	<b>B</b>
		SCF03 - Splined T.2 = 86.1 [Nm] 			
		<b>H</b>		<b>C</b>	<b>C</b>
				<b>D</b>	<b>D</b>
				<b>N</b>	<b>N</b>
				<b>O</b>	<b>O</b>
				<b>Z</b>	<b>Z</b>

Displacement		Standard bodies						
TYPE	CODE	Displacement cm3/rev	Standard threads					
XV-2U/04	<b>41</b>	4	O - O	S - R	B - B	L - M	Z - Z	
XV-2U/06	<b>43</b>	6	O - O	S - R	B - B	L - M	Z - Z	
XV-2U/09	<b>45</b>	9	O - O	S - R	B - B	L - M	Z - Z	
XV-2U/11	<b>47</b>	11	O - O	S - R	B - B	L - M	Z - Z	
XV-2U/14	<b>49</b>	14	P - O	S - R	C - B	L - M	Z - Z	
XV-2U/17	<b>51</b>	17	P - O	S - R	C - B	L - M	Z - Z	
XV-2U/19	<b>53</b>	19	P - O	S - R	C - B	L - M	Z - Z	
XV-2U/22	<b>55</b>	22	P - O	S - R	C - B	L - M	Z - Z	
XV-2U/26	<b>57</b>	26	Q - P	S - R	D - C	L - M	Z - Z	
XV-2U/30	<b>59</b>	30	Q - P	S - S	D - C	L - M	Z - Z	
XV-2U/34	<b>61</b>	34	Q - P	S - S	D - C	L - M	Z - Z	
XV-2U/40	<b>63</b>	40	Q - P	S - S	D - C	L - M	Z - Z	

Table showing standard flange and thread combinations available in stock

Body (threads/flanges)													
	<b>A</b>		<b>B</b>		<b>C</b>		<b>D</b>		<b>E</b>		<b>F</b>		<b>G</b>
	<b>H</b>		<b>I</b>		<b>L</b>		<b>M</b>		<b>N</b>		<b>O</b>		<b>P</b>
	<b>Q</b>		<b>R</b>		<b>S</b>		<b>T</b>		<b>U</b>		<b>V</b>		<b>Z</b>

# unidirectional motor - series XV

# XV-2U

SAE A TYPE MOTOR  
 ø82.5 FLANGE - SPLINED SHAFT

**X 2 U 51 52 I S R A**

Series	X	series XV
Group	2	group 2
Category	U	unidirectional motor
Displacement	51	17
Flange	52	Ø82.5 SAE A right rotation (with OR)
Shaft	I	SCF04 - Splined ø15.456 z=9, H=22.5 - SAE J498 9T 16/32DP
Body	IN	inlet - Ø40 a 45° Ø20 M6
	OUT	outlet - Ø35 a 45° Ø15 M6
Cover	A	standard

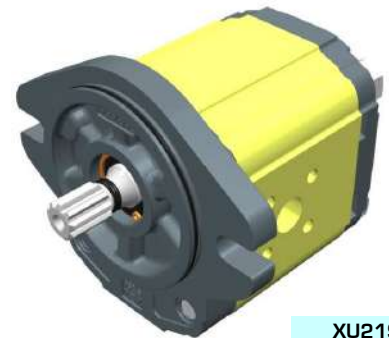

XU219

Technical data table						
TYPE	Displacement cm3/rev	Max. Pressure		CODE		
		P1 bar	P3 bar	Left rotation	Right rotation	
XV-2U/04	4,20	260	300	X 2 U 41 51 I S R A	X 2 U 41 52 I S R A	
XV-2U/06	6,00	260	300	X 2 U 43 51 I S R A	X 2 U 43 52 I S R A	
XV-2U/09	8,40	260	300	X 2 U 45 51 I S R A	X 2 U 45 52 I S R A	
XV-2U/11	10,80	260	300	X 2 U 47 51 I S R A	X 2 U 47 52 I S R A	
XV-2U/14	14,40	250	290	X 2 U 49 51 I S R A	X 2 U 49 52 I S R A	
XV-2U/17	16,80	230	270	X 2 U 51 51 I S R A	X 2 U 51 52 I S R A	
XV-2U/19	19,20	210	250	X 2 U 53 51 I S R A	X 2 U 53 52 I S R A	
XV-2U/22	22,80	200	240	X 2 U 55 51 I S R A	X 2 U 55 52 I S R A	
XV-2U/26	26,20	170	210	X 2 U 57 51 I S R A	X 2 U 57 52 I S R A	
XV-2U/30	30,00	160	200	X 2 U 59 51 I S S A	X 2 U 59 52 I S S A	
XV-2U/34	34,20	150	190	X 2 U 61 51 I S S A	X 2 U 61 52 I S S A	
XV-2U/40	39,60	140	180	X 2 U 63 51 I S S A	X 2 U 63 52 I S S A	

P1) Max. working pressure - P3) Max. peak pressure

For heavy-duty applications, it is recommended to check the admissible torque of the shaft

Dimensions table										
TYPE	Weight kg	A	B	C	D	E	F	D	E	F
		mm	mm	mm	IN			OUT		
XV-2U/04	2,280	88,0	39,4	78,0	ø15	35	M6x1	ø20	40	M6x1
XV-2U/06	2,380	91,0	39,4	81,0	ø15	35	M6x1	ø20	40	M6x2
XV-2U/09	2,480	95,0	41,4	85,0	ø15	35	M6x1	ø20	40	M6x3
XV-2U/11	2,580	99,0	45,8	89,0	ø15	35	M6x1	ø20	40	M6x4
XV-2U/14	2,780	105,0	45,8	95,0	ø15	35	M6x1	ø20	40	M6x5
XV-2U/17	2,880	109,0	45,8	99,0	ø15	35	M6x1	ø20	40	M6x6
XV-2U/19	2,980	113,0	45,8	103,0	ø15	35	M6x1	ø20	40	M6x7
XV-2U/22	3,130	119,0	53,3	109,0	ø15	35	M6x1	ø20	40	M6x8
XV-2U/26	3,230	123,0	53,3	113,0	ø15	35	M6x1	ø20	40	M6x9
XV-2U/30	3,480	131,0	61,5	121,0	ø20	40	M6x1	ø20	40	M6x10
XV-2U/34	3,680	138,0	61,5	128,0	ø20	40	M6x1	ø20	40	M6x11
XV-2U/40	3,880	147,0	61,5	137,0	ø20	40	M6x1	ø20	40	M6x12

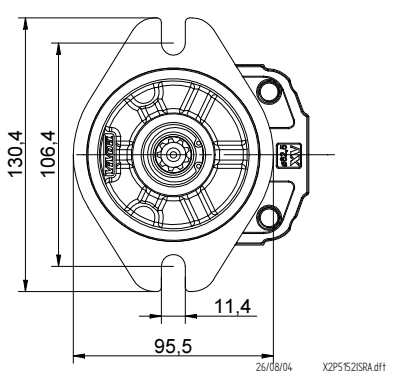
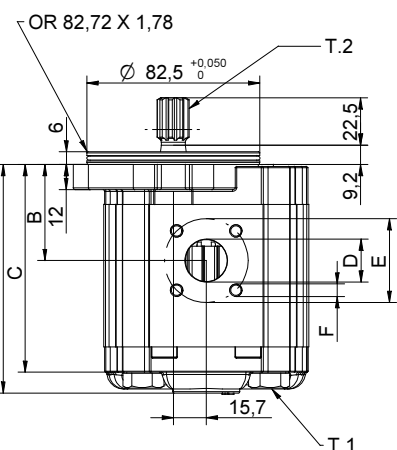
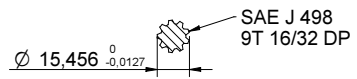
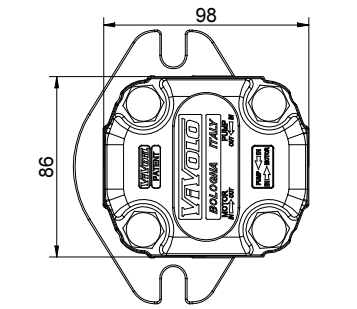

T.1 = 54÷58.9 [Nm] - screw tightening torque M10

T.2 = 67.1 [Nm] - admissible shaft torque (N.B. When choosing a shaft, always check the admissible torque).

# Table of variations

**XV-2U**

## ø82.5 FLANGE "SAE A"

ø82.5 FLANGE "SAE A"				Shaft				Cover			
Left rotation		Right rotation		A		B		Left rotation		Right rotation	
	51		52	CI001 - Parallel T.2 = 44.1 [Nm]		CI002 - Parallel T.2 = 67.5 [Nm]					A
	53		54	CO001 - Tapered T.2 = 233.2 [Nm]		CO002 - Tapered T.2 = 233.2 [Nm]					B
Without OR		Without OR		SCF04 - Splined T.2 = 67.1 [Nm]							C
											D
											N
											O

Displacement		Standard bodies						
TYPE	CODE	Displacement cm3/rev	Standard threads					
XV-2U/04	41	4	O - O	S - R	B - B	L - M	Z - Z	
XV-2U/06	43	6	O - O	S - R	B - B	L - M	Z - Z	
XV-2U/09	45	9	O - O	S - R	B - B	L - M	Z - Z	
XV-2U/11	47	11	O - O	S - R	B - B	L - M	Z - Z	
XV-2U/14	49	14	P - O	S - R	C - B	L - M	Z - Z	
XV-2U/17	51	17	P - O	S - R	C - B	L - M	Z - Z	
XV-2U/19	53	19	P - O	S - R	C - B	L - M	Z - Z	
XV-2U/22	55	22	P - O	S - R	C - B	L - M	Z - Z	
XV-2U/26	57	26	Q - P	S - R	D - C	L - M	Z - Z	
XV-2U/30	59	30	Q - P	S - S	D - C	L - M	Z - Z	
XV-2U/34	61	34	Q - P	S - S	D - C	L - M	Z - Z	
XV-2U/40	63	40	Q - P	S - S	D - C	L - M	Z - Z	

Table showing standard flange and thread combinations available in stock

Body (threads/flanges)													
	A		B		C		D		E		F		G
	H		I		L		M		N		O		P
	Q		R		S		T		U		V	Closed Body	Z

# unidirectional motor - series XV

**XV-3U**

**STANDARD EUROPEAN MOTOR**  
**ø50.8 FLANGE - TAPER SHAFT**

**X 3 U 78 02 A B B A**

Series	X	series XV
Group	3	group 3
Category	U	unidirectional motor
Displacement	78	38
Flange	02	Ø50.8 right rotation
Shaft	A	CO001 - Tapered 1:8 - ø22 - key thk.4
Body	IN	inlet - Ø51 Ø27 M10
	OUT	outlet - Ø51 Ø27 M10
Cover	A	standard

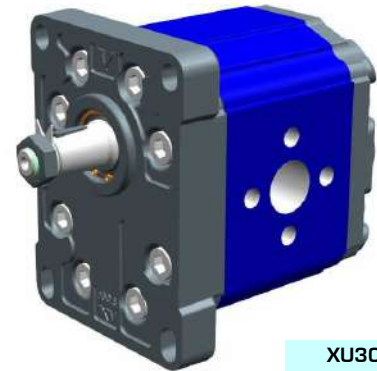

**XU301**

**Technical data table**

TYPE	Displacement cm3/rev	Max. Pressure		CODE																	
		P1 bar	P3 bar	Left rotation			Right rotation														
XV-3U/15	14,89	300	320	X	3	U	66	01	A	A	A	A	X	3	U	66	02	A	A	A	A
XV-3U/18	17,37	300	320	X	3	U	68	01	A	A	A	A	X	3	U	68	02	A	A	A	A
XV-3U/21	21,10	280	300	X	3	U	70	01	A	A	A	A	X	3	U	70	02	A	A	A	A
XV-3U/27	26,97	250	270	X	3	U	72	01	A	A	A	A	X	3	U	72	02	A	A	A	A
XV-3U/32	32,27	250	270	X	3	U	74	01	A	B	B	A	X	3	U	74	02	A	B	B	A
XV-3U/38	38,47	250	270	X	3	U	78	01	A	B	B	A	X	3	U	78	02	A	B	B	A
XV-3U/43	43,44	250	270	X	3	U	79	01	A	B	B	A	X	3	U	79	02	A	B	B	A
XV-3U/47	47,16	230	250	X	3	U	80	01	A	B	B	A	X	3	U	80	02	A	B	B	A
XV-3U/51	50,88	230	250	X	3	U	81	01	A	B	B	A	X	3	U	81	02	A	B	B	A
XV-3U/54	54,60	230	250	X	3	U	82	01	A	B	B	A	X	3	U	82	02	A	B	B	A
XV-3U/61	60,81	230	250	X	3	U	83	01	A	C	C	A	X	3	U	83	02	A	C	C	A
XV-3U/64	64,53	210	230	X	3	U	85	01	A	C	C	A	X	3	U	85	02	A	C	C	A
XV-3U/70	70,74	200	220	X	3	U	86	01	A	C	C	A	X	3	U	86	02	A	C	C	A
XV-3U/74	74,46	180	200	X	3	U	87	01	A	C	C	A	X	3	U	87	02	A	C	C	A
XV-3U/90	86,87	150	170	X	3	U	89	01	A	C	C	A	X	3	U	89	02	A	C	C	A

P1) Max. working pressure - P3) Max. peak pressure

For heavy-duty applications, it is recommended to check the admissible torque of the shaft

**Dimensions table**

TYPE	Weight kg	A	B	D	E	F	D	E	F
		mm	mm	IN			OUT		
XV-3U/15	7,010	124,0	61,0	ø20	40	M8	ø20	40	M8
XV-3U/18	7,070	126,0	62,0	ø20	40	M8	ø20	40	M8
XV-3U/21	7,150	129,0	63,5	ø20	40	M8	ø20	40	M8
XV-3U/27	7,250	133,0	65,5	ø20	40	M8	ø20	40	M8
XV-3U/32	7,390	138,0	68,0	ø27	51	M10	ø27	51	M10
XV-3U/38	7,520	143,0	70,5	ø27	51	M10	ø27	51	M10
XV-3U/43	7,630	147,0	72,5	ø27	51	M10	ø27	51	M10
XV-3U/47	7,710	150,0	74,0	ø27	51	M10	ø27	51	M10
XV-3U/51	7,790	153,0	75,5	ø27	51	M10	ø27	51	M10
XV-3U/54	7,870	156,0	77,0	ø27	51	M10	ø27	51	M10
XV-3U/61	8,010	161,0	79,5	ø36	62	M10	ø36	62	M10
XV-3U/64	8,090	164,0	81,0	ø36	62	M10	ø36	62	M10
XV-3U/70	8,220	169,0	83,5	ø36	62	M10	ø36	62	M10
XV-3U/74	8,300	172,0	85,0	ø36	62	M10	ø36	62	M10
XV-3U/90	8,570	182,0	90,0	ø36	62	M10	ø36	62	M10

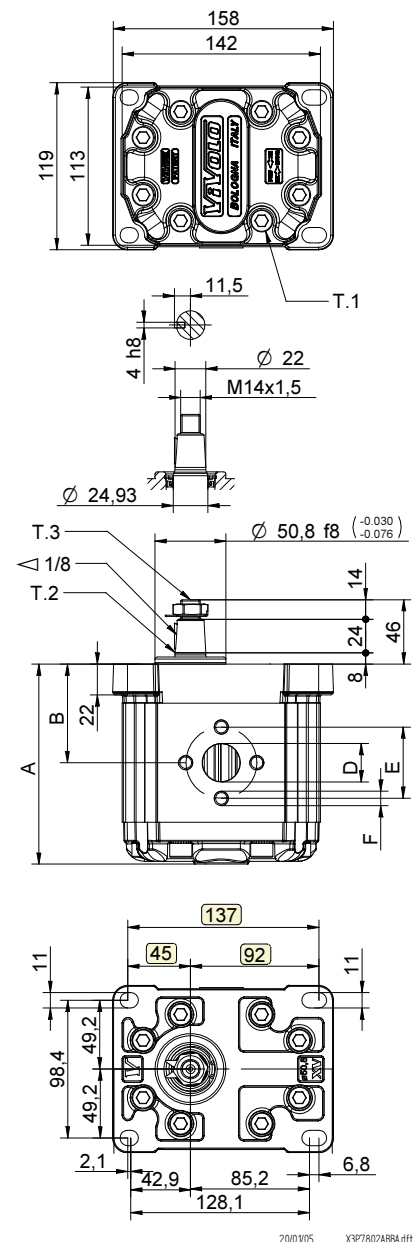

T.1 = 60÷65 [Nm] - screw tightening torque M10

T.3 = 75 [Nm] - torque wrench setting 22

T.2 = 482 [Nm] - admissible shaft torque (N.B. When choosing a shaft, always check the admissible torque).

# Table of variations

**XV-3U**

## ø50.8 FLANGE

ø50.8 FLANGE		Shaft		Cover		
Left rotation	Right rotation			Left rotation	Right rotation	
		CO001 - Tapered T.2 = 482 [Nm]	A			A
01	02		B			B
		CI004 - Parallel T.2 = 180 [Nm]	C			C
			H			D
		SCF04 - Splined T.2 = 264 [Nm]	I			

Displacement	
TYPE	CODE
XV-3U/15	66
XV-3U/18	68
XV-3U/21	70
XV-3U/27	72
XV-3U/32	74
XV-3U/38	78
XV-3U/43	79
XV-3U/47	80
XV-3U/51	81
XV-3U/54	82
XV-3U/61	83
XV-3U/64	85
XV-3U/70	86
XV-3U/74	87
XV-3U/90	89

Standard bodies				
Displacement cm <sup>3</sup> /rev	Standard threads			
	15	A - A	D - D	H - H
18	A - A	D - D	H - H	
21	A - A	D - D	H - H	
27	A - A	E - E	H - H	
32	B - B	E - E	H - H	
38	B - B	E - E	H - H	
43	B - B	E - E	H - H	
47	B - B	E - E	H - H	
51	B - B	E - E	H - H	
54	B - B	E - E	H - H	
61	C - C	F - F		
64	C - C	F - F		
70	C - C	F - F		
74	C - C	F - F		
90	C - C	F - F		

Table showing standard flange and thread combinations available in stock

Body (threads/flanges)													
	A		B		C		D		E		F		G
	H		I		L		M		N		O		P
Closed Body	Z												

# unidirectional motor - series XV

**XV-3U**

**STANDARD EUROPEAN MOTOR  
ø50.8 FLANGE - TAPER SHAFT**

**X 3 U 78 02 A E E A**

Series	X	series XV
Group	3	group 3
Category	U	unidirectional motor
Displacement	78	38
Flange	02	ø50.8 right rotation
Shaft	A	CO001 - Tapered 1:8 - ø22 - key thk.4
Body	IN	inlet - 1" BSP
	OUT	outlet - 1" BSP
Cover	A	standard

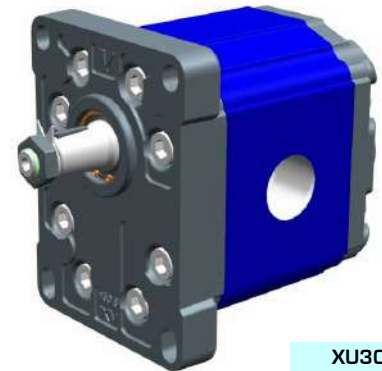

**XU302**

**Technical data table**

TYPE	Displacement cm3/rev	Max. Pressure		CODE	
		P1 bar	P3 bar	Left rotation	Right rotation
XV-3U/15	14,89	300	320	X 3 U 66 01 A D D A	X 3 U 66 02 A D D A
XV-3U/18	17,37	300	320	X 3 U 68 01 A D D A	X 3 U 68 02 A D D A
XV-3U/21	21,10	280	300	X 3 U 70 01 A D D A	X 3 U 70 02 A D D A
XV-3U/27	26,97	250	270	X 3 U 72 01 A E E A	X 3 U 72 02 A E E A
XV-3U/32	32,27	250	270	X 3 U 74 01 A E E A	X 3 U 74 02 A E E A
XV-3U/38	38,47	250	270	X 3 U 78 01 A E E A	X 3 U 78 02 A E E A
XV-3U/43	43,44	250	270	X 3 U 79 01 A E E A	X 3 U 79 02 A E E A
XV-3U/47	47,16	230	250	X 3 U 80 01 A E E A	X 3 U 80 02 A E E A
XV-3U/51	50,88	230	250	X 3 U 81 01 A E E A	X 3 U 81 02 A E E A
XV-3U/54	54,60	230	250	X 3 U 82 01 A E E A	X 3 U 82 02 A E E A
XV-3U/61	60,81	230	250	X 3 U 83 01 A F F A	X 3 U 83 02 A F F A
XV-3U/64	64,53	210	230	X 3 U 85 01 A F F A	X 3 U 85 02 A F F A
XV-3U/70	70,74	200	220	X 3 U 86 01 A F F A	X 3 U 86 02 A F F A
XV-3U/74	74,46	180	200	X 3 U 87 01 A F F A	X 3 U 87 02 A F F A
XV-3U/90	86,87	150	170	X 3 U 89 01 A F F A	X 3 U 89 02 A F F A

P1) Max. working pressure - P3) Max. peak pressure

For heavy-duty applications, it is recommended to check the admissible torque of the shaft

**Dimensions table**

TYPE	Weight	A	B	D	D
	kg	mm	mm	IN	OUT
XV-3U/15	7,010	124,0	61,0	3/4" BSPP	3/4" BSPP
XV-3U/18	7,070	126,0	62,0	3/4" BSPP	3/4" BSPP
XV-3U/21	7,150	129,0	63,5	3/4" BSPP	3/4" BSPP
XV-3U/27	7,250	133,0	65,5	1" BSPP	1" BSPP
XV-3U/32	7,390	138,0	68,0	1" BSPP	1" BSPP
XV-3U/38	7,520	143,0	70,5	1" BSPP	1" BSPP
XV-3U/43	7,630	147,0	72,5	1" BSPP	1" BSPP
XV-3U/47	7,710	150,0	74,0	1" BSPP	1" BSPP
XV-3U/51	7,790	153,0	75,5	1" BSPP	1" BSPP
XV-3U/54	7,870	156,0	77,0	1" BSPP	1" BSPP
XV-3U/61	8,010	161,0	79,5	1" 1/4 BSPP	1" 1/4 BSPP
XV-3U/64	8,090	164,0	81,0	1" 1/4 BSPP	1" 1/4 BSPP
XV-3U/70	8,220	169,0	83,5	1" 1/4 BSPP	1" 1/4 BSPP
XV-3U/74	8,300	172,0	85,0	1" 1/4 BSPP	1" 1/4 BSPP
XV-3U/90	8,570	182,0	90,0	1" 1/4 BSPP	1" 1/4 BSPP

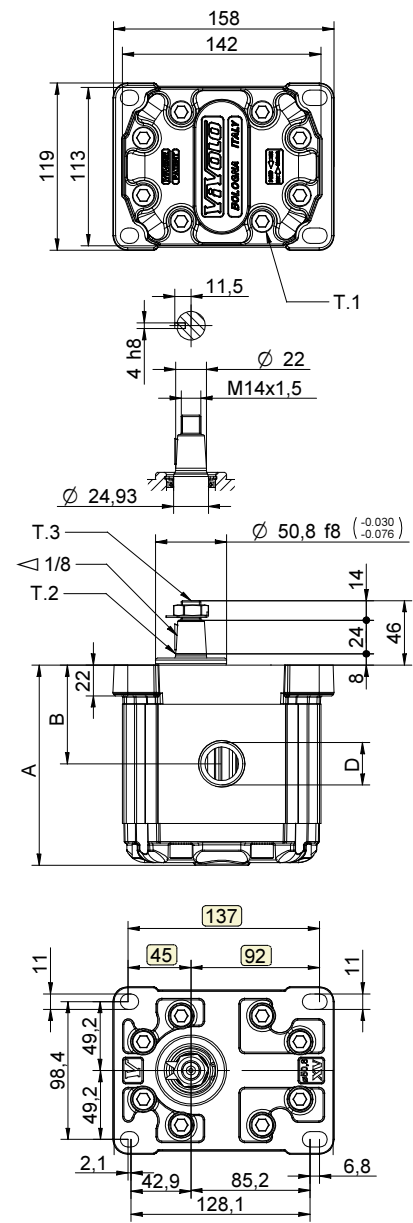

26/08/04 X3P7802AEEA.dft

T.1 = 60÷65 [Nm] - screw tightening torque M10

T.3 = 75 [Nm] - torque wrench setting 22

T.2 = 482 [Nm] - admissible shaft torque (N.B. When choosing a shaft, always check the admissible torque).

# Table of variations

**XV-3U**

## ø50.8 FLANGE

ø50.8 FLANGE		Shaft		Cover		
Left rotation	Right rotation			Left rotation	Right rotation	
		CO001 - Tapered T.2 = 482 [Nm]	A			A
01	02		B			B
		CI004 - Parallel T.2 = 180 [Nm]	C			C
			H			D
		SCF04 - Splined T.2 = 264 [Nm]	I			

Displacement	
TYPE	CODE
XV-3U/15	66
XV-3U/18	68
XV-3U/21	70
XV-3U/27	72
XV-3U/32	74
XV-3U/38	78
XV-3U/43	79
XV-3U/47	80
XV-3U/51	81
XV-3U/54	82
XV-3U/61	83
XV-3U/64	85
XV-3U/70	86
XV-3U/74	87
XV-3U/90	89

Displacement cm <sup>3</sup> /rev	Standard bodies		
	Standard threads		
15	A - A	D - D	H - H
18	A - A	D - D	H - H
21	A - A	D - D	H - H
27	A - A	E - E	H - H
32	B - B	E - E	H - H
38	B - B	E - E	H - H
43	B - B	E - E	H - H
47	B - B	E - E	H - H
51	B - B	E - E	H - H
54	B - B	E - E	H - H
61	C - C	F - F	
64	C - C	F - F	
70	C - C	F - F	
74	C - C	F - F	
90	C - C	F - F	

Table showing standard flange and thread combinations available in stock

Body (threads/flanges)													
	A		B		C		D		E		F		G
	H		I		L		M		N		O		P
Closed Body	Z												

# unidirectional motor - series XV

**XV-3U**

**SAE B TYPE MOTOR**  
**ø101.6 FLANGE - SPLINED SHAFT**

**X 3 U 78 32 I E E A**

Series	X	series XV
Group	3	group 3
Category	U	unidirectional motor
Displacement	78	38
Flange	32	Ø101.6 SAE B right rotation
Shaft	I	SCF04 - Splined ø21.81 z=13, H=33.55 SAE J498-13T -16/32DP (SAE B)
Body	IN	inlet - 1" BSP
	OUT	outlet - 1" BSP
Cover	A	standard



**XU331**

Technical data table						
TYPE	Displacement cm3/rev	Max. Pressure		CODE		
		P1 bar	P3 bar	Left rotation	Right rotation	
XV-3U/15	14,89	250	270	X 3 U 66 31 I D D A	X 3 U 66 32 I D D A	
XV-3U/18	17,37	250	270	X 3 U 68 31 I D D A	X 3 U 68 32 I D D A	
XV-3U/21	21,10	250	270	X 3 U 70 31 I D D A	X 3 U 70 32 I D D A	
XV-3U/27	26,97	250	270	X 3 U 72 31 I E E A	X 3 U 72 32 I E E A	
XV-3U/32	32,27	250	270	X 3 U 74 31 I E E A	X 3 U 74 32 I E E A	
XV-3U/38	38,47	250	270	X 3 U 78 31 I E E A	X 3 U 78 32 I E E A	
XV-3U/43	43,44	250	270	X 3 U 79 31 I E E A	X 3 U 79 32 I E E A	
XV-3U/47	47,16	230	250	X 3 U 80 31 I E E A	X 3 U 80 32 I E E A	
XV-3U/51	50,88	230	250	X 3 U 81 31 I E E A	X 3 U 81 32 I E E A	
XV-3U/54	54,60	230	250	X 3 U 82 31 I E E A	X 3 U 82 32 I E E A	
XV-3U/61	60,81	230	250	X 3 U 83 31 I F F A	X 3 U 83 32 I F F A	
XV-3U/64	64,53	210	230	X 3 U 85 31 I F F A	X 3 U 85 32 I F F A	
XV-3U/70	70,74	200	220	X 3 U 86 31 I F F A	X 3 U 86 32 I F F A	
XV-3U/74	74,46	180	200	X 3 U 87 31 I F F A	X 3 U 87 32 I F F A	
XV-3U/90	86,87	150	170	X 3 U 89 31 I F F A	X 3 U 89 32 I F F A	

P1) Max. working pressure - P3) Max. peak pressure

For heavy-duty applications, it is recommended to check the admissible torque of the shaft

Dimensions table					
TYPE	Weight	A	B	D	D
	kg	mm	mm	IN	OUT
XV-3U/15	7,010	124,0	61,0	3/4" BSPP	3/4" BSPP
XV-3U/18	7,070	126,0	62,0	3/4" BSPP	3/4" BSPP
XV-3U/21	7,150	129,0	63,5	3/4" BSPP	3/4" BSPP
XV-3U/27	7,250	133,0	65,5	1" BSPP	1" BSPP
XV-3U/32	7,390	138,0	68,0	1" BSPP	1" BSPP
XV-3U/38	7,520	143,0	70,5	1" BSPP	1" BSPP
XV-3U/43	7,630	147,0	72,5	1" BSPP	1" BSPP
XV-3U/47	7,710	150,0	74,0	1" BSPP	1" BSPP
XV-3U/51	7,790	153,0	75,5	1" BSPP	1" BSPP
XV-3U/54	7,870	156,0	77,0	1" BSPP	1" BSPP
XV-3U/61	8,010	161,0	79,5	1" 1/4 BSPP	1" 1/4 BSPP
XV-3U/64	8,090	164,0	81,0	1" 1/4 BSPP	1" 1/4 BSPP
XV-3U/70	8,220	169,0	83,5	1" 1/4 BSPP	1" 1/4 BSPP
XV-3U/74	8,300	172,0	85,0	1" 1/4 BSPP	1" 1/4 BSPP
XV-3U/90	8,570	182,0	90,0	1" 1/4 BSPP	1" 1/4 BSPP

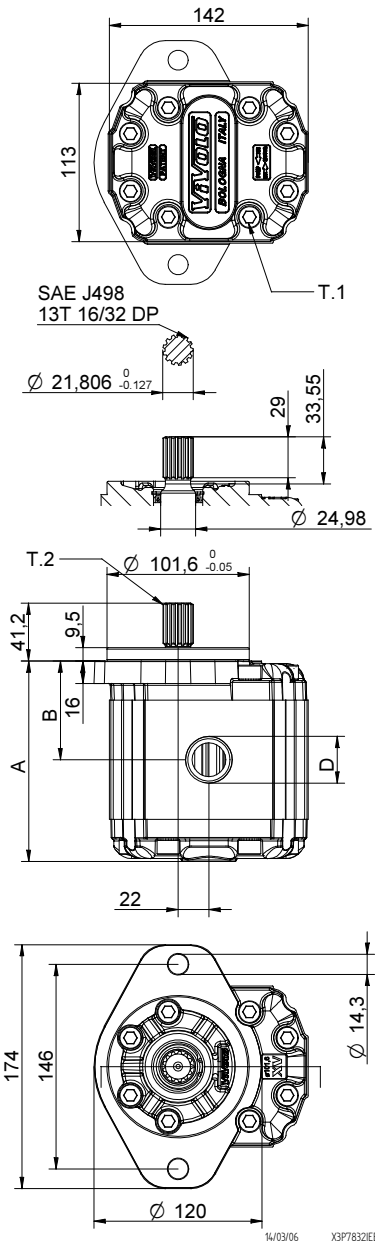

T.1 = 60÷65 [Nm] - screw tightening torque M10

T.2 = 264 [Nm] - admissible shaft torque (N.B. When choosing a shaft, always check the admissible torque).

# Table of variations

**XV-3U**

## ø101.6 FLANGE ""SAE B""

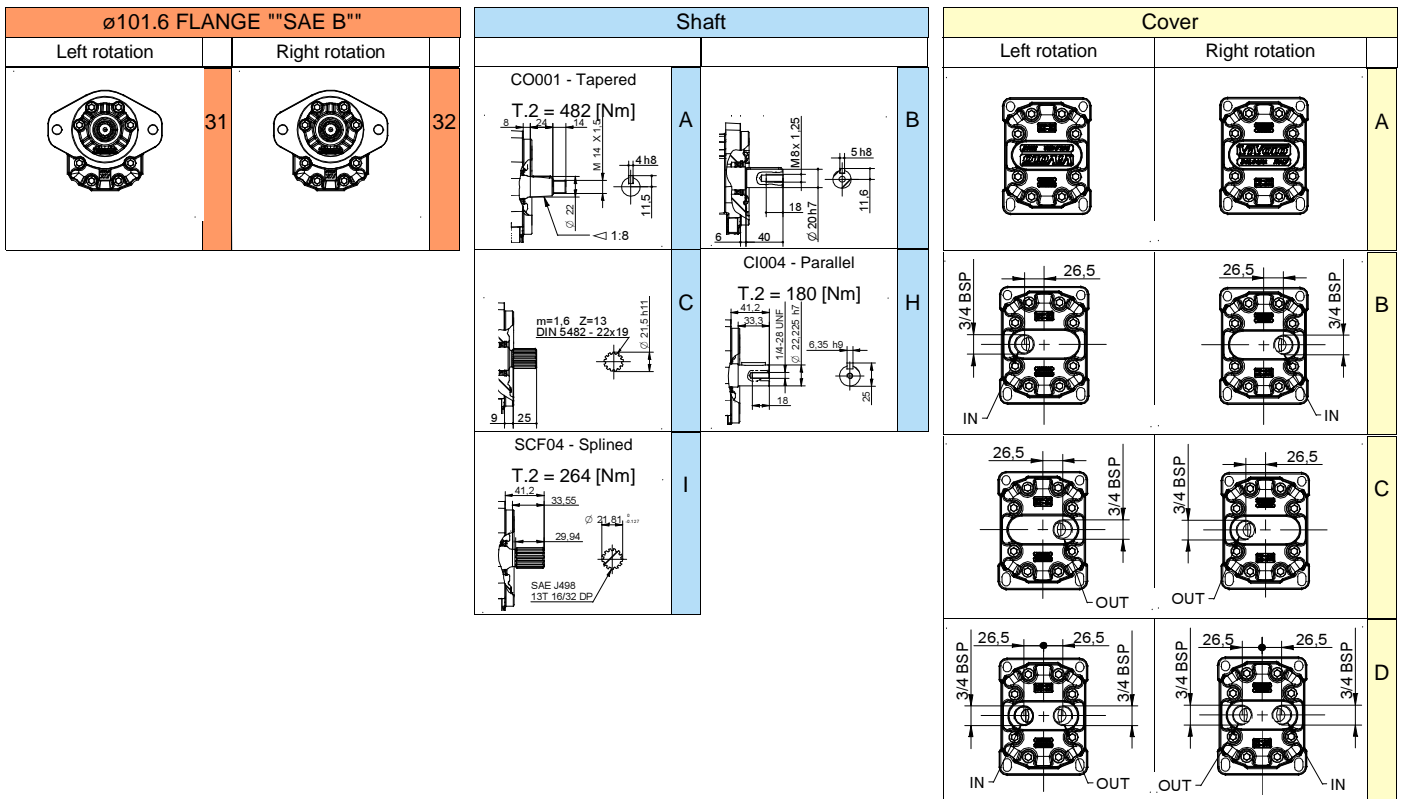

Displacement	
TYPE	CODE
XV-3U/15	66
XV-3U/18	68
XV-3U/21	70
XV-3U/27	72
XV-3U/32	74
XV-3U/38	78
XV-3U/43	79
XV-3U/47	80
XV-3U/51	81
XV-3U/54	82
XV-3U/61	83
XV-3U/64	85
XV-3U/70	86
XV-3U/74	87
XV-3U/90	89

Displacement cm <sup>3</sup> /rev	Standard bodies		
	Standard threads		
15	A - A	D - D	H - H
18	A - A	D - D	H - H
21	A - A	D - D	H - H
27	A - A	E - E	H - H
32	B - B	E - E	H - H
38	B - B	E - E	H - H
43	B - B	E - E	H - H
47	B - B	E - E	H - H
51	B - B	E - E	H - H
54	B - B	E - E	H - H
61	C - C	F - F	
64	C - C	F - F	
70	C - C	F - F	
74	C - C	F - F	
90	C - C	F - F	

Table showing standard flange and thread combinations available in stock

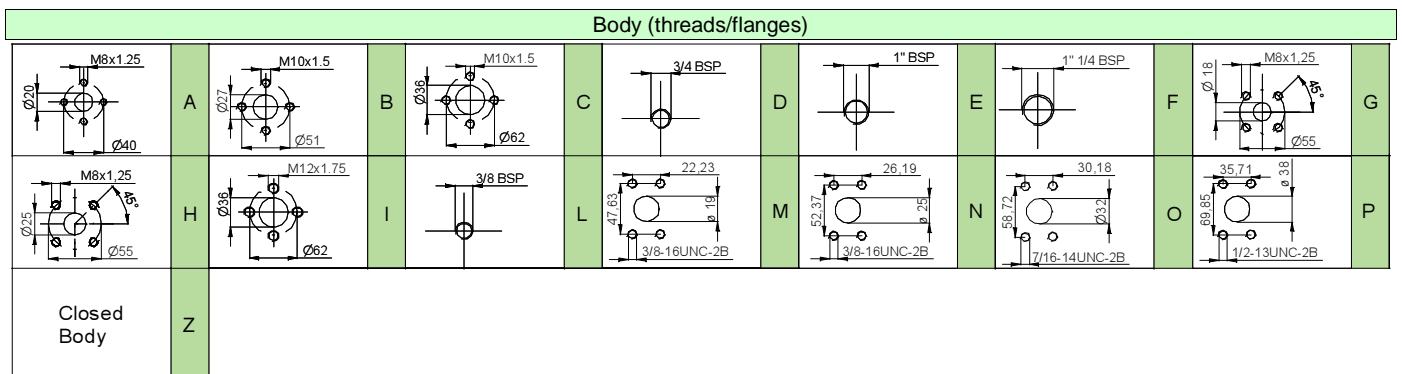

# unidirectional motor - series XV

**XV-3U**

**SAE B TYPE MOTOR**  
**ø101.6 FLANGE - SPLINED SHAFT**

**X 3 U 78 32 I O O A**

Series	X	series XV
Group	3	group 3
Category	U	unidirectional motor
Displacement	78	38
Flange	32	Ø101.6 SAE B right rotation
Shaft	I	SCF04 - Splined ø21.81 z=13, H=33.55 SAE J498-13T -16/32DP (SAE B)
Body	IN	inlet - SAE 30,18 X 58,72 - ø32 - 7/16-14UNC-2B
	OUT	outlet - SAE 30,18 X 58,72 - ø32 - 7/16-14UNC-2B
Cover	A	standard

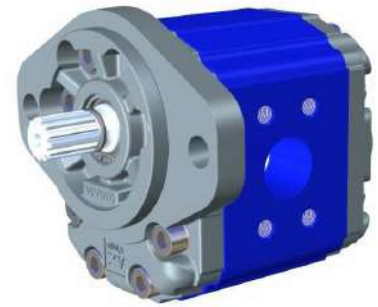

**XU332**

**Technical data table**

TYPE	Displacement cm3/rev	Max. Pressure		CODE	
		P1 bar	P3 bar	Left rotation	Right rotation
XV-3U/15	14,89	250	270	X 3 U 66 31 I N N A	X 3 U 66 32 I N N A
XV-3U/18	17,37	250	270	X 3 U 68 31 I N N A	X 3 U 68 32 I N N A
XV-3U/21	21,10	250	270	X 3 U 70 31 I N N A	X 3 U 70 32 I N N A
XV-3U/27	26,97	250	270	X 3 U 72 31 I N N A	X 3 U 72 32 I N N A
XV-3U/32	32,27	250	270	X 3 U 74 31 I O O A	X 3 U 74 32 I O O A
XV-3U/38	38,47	250	270	X 3 U 78 31 I O O A	X 3 U 78 32 I O O A
XV-3U/43	43,44	250	270	X 3 U 79 31 I O O A	X 3 U 79 32 I O O A
XV-3U/47	47,16	230	250	X 3 U 80 31 I O O A	X 3 U 80 32 I O O A
XV-3U/51	50,88	230	250	X 3 U 81 31 I O O A	X 3 U 81 32 I O O A
XV-3U/54	54,60	230	250	X 3 U 82 31 I O O A	X 3 U 82 32 I O O A
XV-3U/61	60,81	230	250	X 3 U 83 31 I P P A	X 3 U 83 32 I P P A
XV-3U/64	64,53	210	230	X 3 U 85 31 I P P A	X 3 U 85 32 I P P A
XV-3U/70	70,74	200	220	X 3 U 86 31 I P P A	X 3 U 86 32 I P P A
XV-3U/74	74,46	180	200	X 3 U 87 31 I P P A	X 3 U 87 32 I P P A
XV-3U/90	86,87	150	170	X 3 U 89 31 I P P A	X 3 U 89 32 I P P A

P1) Max. working pressure - P3) Max. peak pressure

For heavy-duty applications, it is recommended to check the admissible torque of the shaft

**Dimensions table**

TYPE	Weight kg	A	B	D	E	F	G
		mm	mm	IN - OUT			
XV-3U/15	7,010	124,0	61,0	ø25	52,37	26,19	3/8-16UNC-2B
XV-3U/18	7,070	126,0	62,0	ø25	52,37	26,19	3/8-16UNC-2B
XV-3U/21	7,150	129,0	63,5	ø25	52,37	26,19	3/8-16UNC-2B
XV-3U/27	7,250	133,0	65,5	ø25	52,37	26,19	3/8-16UNC-2B
XV-3U/32	7,390	138,0	68,0	ø32	58,72	30,18	7/16-14UNC-2B
XV-3U/38	7,520	143,0	70,5	ø32	58,72	30,18	7/16-14UNC-2B
XV-3U/43	7,630	147,0	72,5	ø32	58,72	30,18	7/16-14UNC-2B
XV-3U/47	7,710	150,0	74,0	ø32	58,72	30,18	7/16-14UNC-2B
XV-3U/51	7,790	153,0	75,5	ø32	58,72	30,18	7/16-14UNC-2B
XV-3U/54	7,870	156,0	77,0	ø32	58,72	30,18	7/16-14UNC-2B
XV-3U/61	8,010	161,0	79,5	ø38	69,85	35,71	1/2-13UNC-2B
XV-3U/64	8,090	164,0	81,0	ø38	69,85	35,71	1/2-13UNC-2B
XV-3U/70	8,220	169,0	83,5	ø38	69,85	35,71	1/2-13UNC-2B
XV-3U/74	8,300	172,0	85,0	ø38	69,85	35,71	1/2-13UNC-2B
XV-3U/90	8,570	182,0	90,0	ø38	69,85	35,71	1/2-13UNC-2B

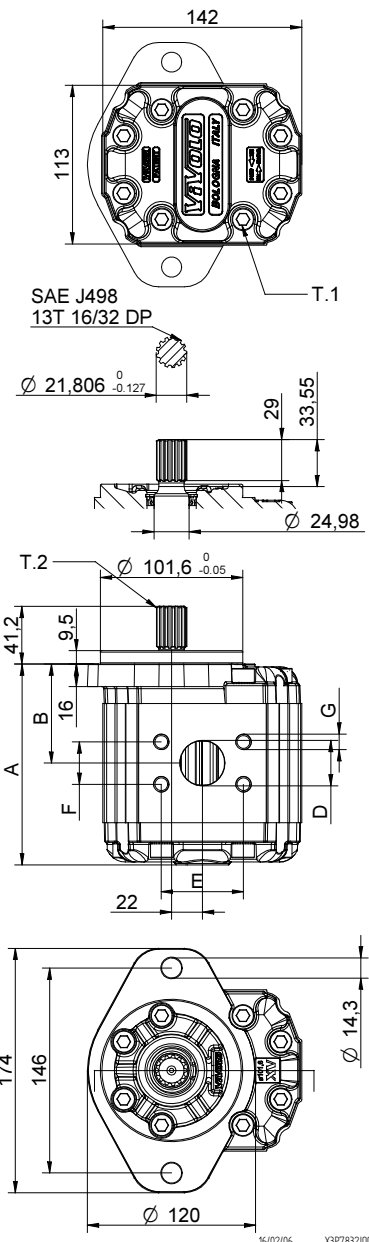

T.1 = 60÷65 [Nm] - screw tightening torque M10

T.2 = 264 [Nm] - admissible shaft torque (N.B. When choosing a shaft, always check the admissible torque).

# Table of variations

**XV-3U**

## ø101.6 FLANGE ""SAE B""

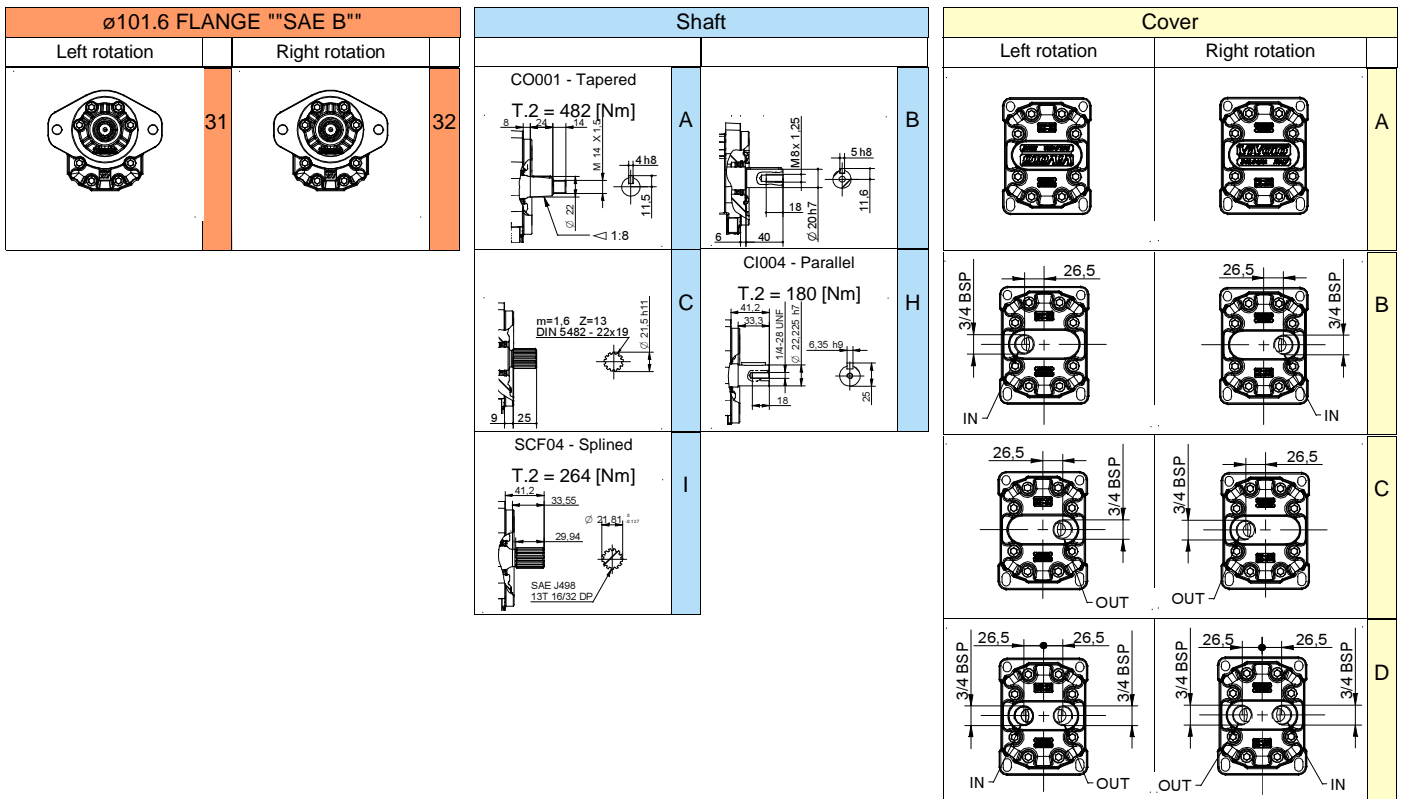

Displacement	
TYPE	CODE
XV-3U/15	66
XV-3U/18	68
XV-3U/21	70
XV-3U/27	72
XV-3U/32	74
XV-3U/38	78
XV-3U/43	79
XV-3U/47	80
XV-3U/51	81
XV-3U/54	82
XV-3U/61	83
XV-3U/64	85
XV-3U/70	86
XV-3U/74	87
XV-3U/90	89

Standard bodies				
Displacement cm <sup>3</sup> /rev	Standard threads			
	15	A - A	D - D	H - H
18	A - A	D - D	H - H	
21	A - A	D - D	H - H	
27	A - A	E - E	H - H	
32	B - B	E - E	H - H	
38	B - B	E - E	H - H	
43	B - B	E - E	H - H	
47	B - B	E - E	H - H	
51	B - B	E - E	H - H	
54	B - B	E - E	H - H	
61	C - C	F - F		
64	C - C	F - F		
70	C - C	F - F		
74	C - C	F - F		
90	C - C	F - F		

Table showing standard flange and thread combinations available in stock

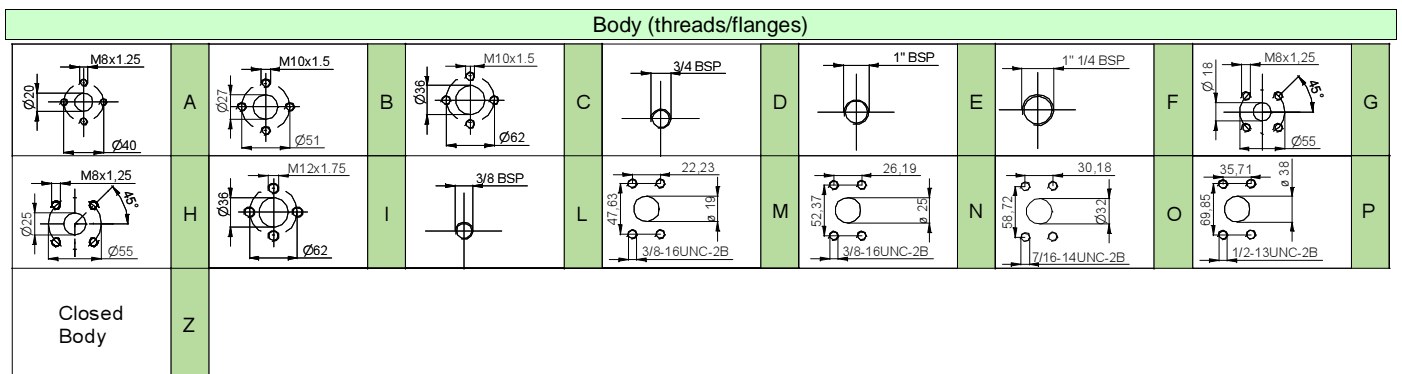



**DOUBLE SHAFT - Variant VA**

All versions may be supplied with a double shaft using all types of shafts and flanges  
As per catalogue

Example of order code

Standard -----X0P0602ABBA  
With double shaft -----X0P0602ABBA **VA**

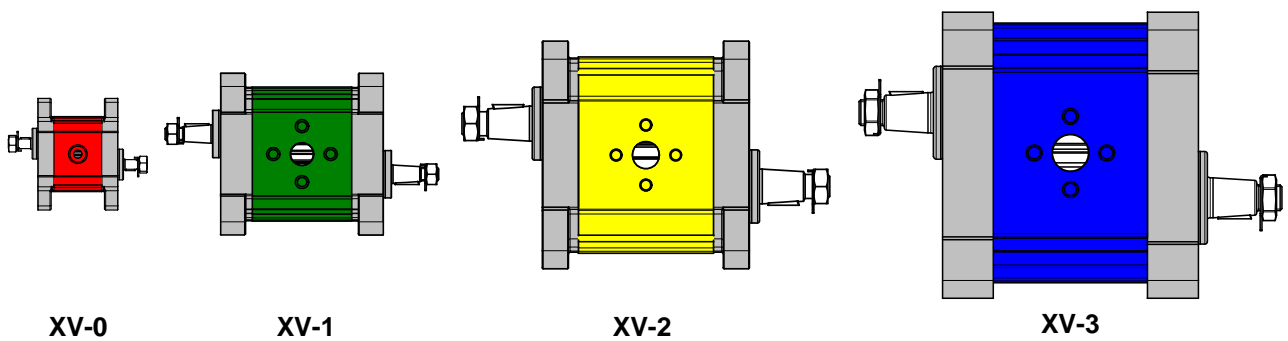

**SEALS made of FKM (viton) variant VITON**

All versions may be supplied with **FKM (viton)** seals

Example of order code

Standard-----X0P0602ABBA  
With FKM (viton ) seals -----X0P0602ABBA **VITON**

**O-RINGS**

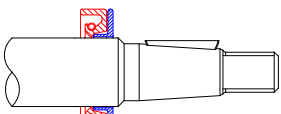
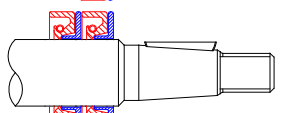
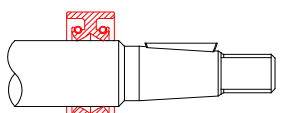
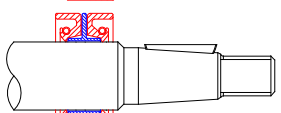
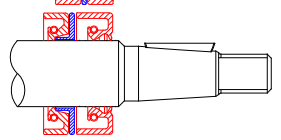
Variant <b>VDC</b>		Oil seal with backup washer (standard for motors)
Variant <b>VDCX</b>		Double oil seal with double backup washer
Variant <b>VDB</b>		DUPLEX oil seal
Variant <b>VDBX</b>		Double opposed oil seal with backup washer
Variant <b>VDCO</b>		Motor Oil Seal with backup washer + Standard Oil Seal

Example of order code

Standard-----X1P0602FIIA  
With oil seal and retaining washer -----X1P0602FIIA **VDC**

## Pressure-relief valve VM25 for XV0 series

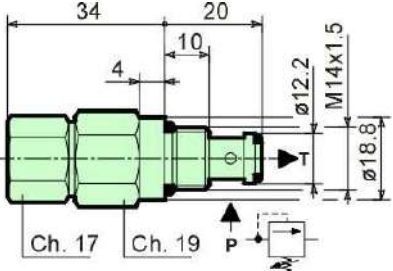
	Technical specifications	
	Capacity	25 l/min
	Max pressure in P	315 bars
	Max pressure in T	315 bars
	Setting range of spring <b>Type 01</b>	20-140 bars
	Setting range of spring <b>Type 02</b>	70-315 bars
	Required filtration	10-15 µm
	Oil viscosity range	2.8-350 cSt
	Recommended oil temperature	-20 + 80 °C
	Seal material	Buna N
	Weight	0.110 kg
	Pressures with flow of 1 l/min: opening value in relation to setting	95%
	Closing value in relation to setting	75%
	Hydraulic oil	HM, HV ISO 6074

## Pressure-relief valve VM50 for XV1 and XV2 series

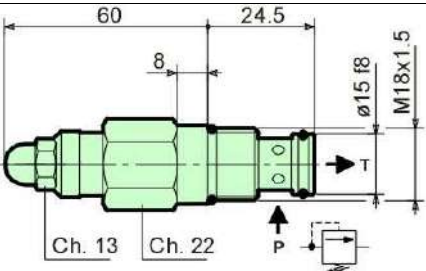
	Technical specifications	
	Capacity	50/min
	Max pressure in P	350 bars
	Max pressure in T	350 bars
	Setting range of spring <b>Type 01</b>	10-105 bars
	Setting range of spring <b>Type 02</b>	70-210 bars
	Setting range of spring <b>Type 03</b>	140-350 bars
	Required filtration	10-15 µm
	Oil viscosity range	2.8-350 cSt
	Recommended oil temperature	-20 + 80 °C
	Seal material	Buna N
	Weight	0.125 kg
	Pressures with flow of 1 l/min: opening value in relation to setting	95%
	Closing value in relation to setting	75%
	Hydraulic oil	HM, HV ISO 6074

### Standard test settings

TYPE	Pressure (bars)	Capacity (l/min)	Pressure increase (bars x turn of screw)
<b>1</b> (10-105 bars)	50	5	15
<b>2</b> (70-210 bars)	130	5	32
<b>3</b> (140-350 bars)	200	5	67

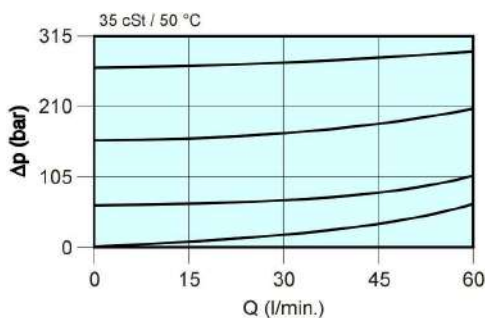

### Performance of VM25 and VM50 valves

**Δp** = Pressure drop in bars

**Q** = Capacity in litres per minute

**90° STEEL ELBOWS**

Code	Type	A	B	C	D	E	F	G	OR	V	weigth
									O ring	Screw	
8KRG001	RG 26/12-3/8"BSP	3/8"	26	5,5	12	18	9,5	27	ø14,00x1,78	M5x18	0,13
8KRG002	RG 26/12-1/2"BSP	1/2"	26	5,5	12	18	9,5	27	ø14,00x1,78	M5x18	0,12
8KRG003	RG 30/13,5 -3/8"BSP	3/8"	30	6,5	13,5	18	9,5	27	ø15,88x2,62	M6x20	0,17
8KRG004	RG 30/13,5 -1/2"BSP	1/2"	30	6,5	13,5	18	9,5	27	ø15,88x2,62	M6x20	0,16
8KRG005	RG 40/20-1/2"BSP	1/2"	40	8,5	20	21	10,5	38	ø23,81x2,62	M8x25	0,36
8KRG006	RG 40/20-3/4"BSP	3/4"	40	8,5	20	21	10,5	38	ø23,81x2,62	M8x25	0,32
8KRG007	RG 40/23-3/4"BSP	3/4"	40	8,5	23,5	21	10,5	38	ø25,12x1,78	M8x25	0,29
8KRG008	RG 51/27-1"BSP	1"	51	10,5	27	27	13,5	47	ø31,42x2,62	M10x30	0,7
8KRG009	RG 51/27-3/4" BSP	3/4"	51	10,5	27	27	13,5	47	ø31,42x2,62	M10x30	0,7
8KRG011	RG 56/34-3/4" BSP	3/4"	56	10,5	34	27	13,5	47	ø37,77x2,62	M10x30	0,72
8KRG012	RG 62/36-1"1/4 BSP	1"1/4	62	10,5	36	36	19	56	ø41,28x3,53	M10x30	0,94
8KRG015	RG 62/36-1"1/4 BSP M12	1"1/4	62	12,5	36	36	19	56	ø41,28x3,53	M12x35	0,94
8KRG013	RG 72,5/45-1"1/2 BSP	1"1/2	72,5	12,5	45	38	16	58	ø49,20x3,53	M12x35	1,23
8KRG014	RG 92/65-2" BSP	2	92	12,5	65	50	21	75	ø69,85x3,53	M12x40	1,65

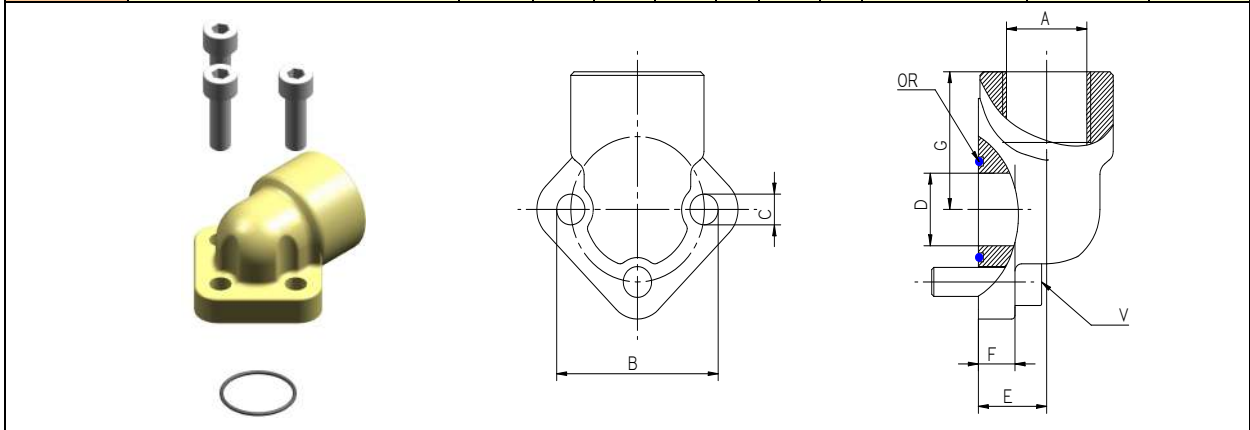

**STRAIGHT STEEL UNIONS**

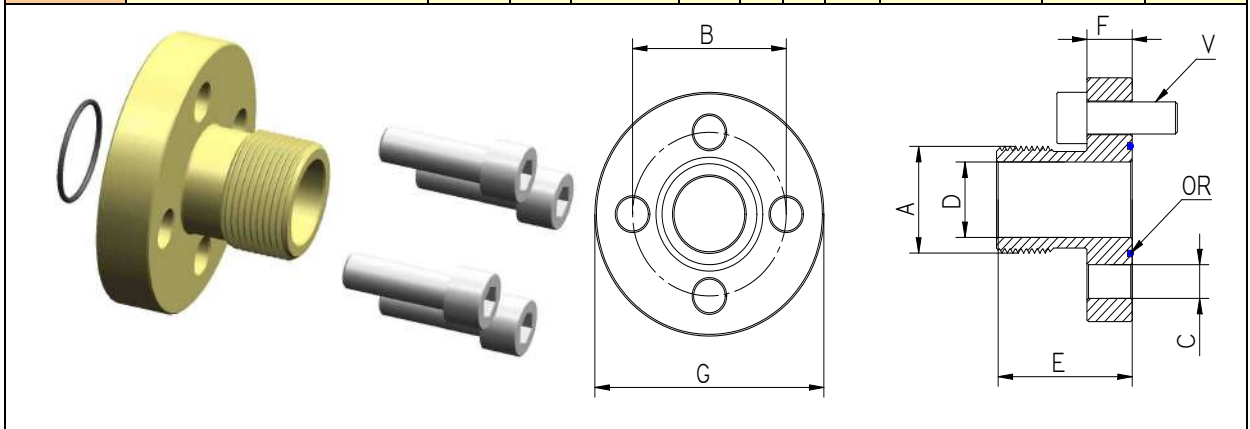
Code	Type	A	B	C	D	E	F	G	OR	V	Weigth
									O ring	Screw	
8KRD001	RD 26/12-3/8"BSP	3/8"	26	5,5	12	32	10	39	ø14,00x1,78	M5x18	0,11
8KRD002	RD 30/13,5-1/2"BSP	1/2"	30	6,5	13,5	40	10	44	ø15,88x2,62	M6x20	0,14
8KRD005	RD 40/20-3/4"BSP	3/4"	40	8,5	20	42	12	51	ø23,81x2,62	M8x25	0,3
8KRD006	RD 40/23,5-3/4"BSP	3/4"	40	8,5	23,5	42	12	51	ø25,12x1,78	M8x25	0,29
8KRD007	RD 51/27-1"BSP	1"	51	10,5	27	43	12	68	ø31,42x2,62	M10x25	0,46
8KRD008	RD 56/34-1"1/4 BSP	1" 1/4	56	10,5	34	53	12	73	ø37,77x2,62	M10x25	0,68
8KRD009	RD 62/36-1"1/4 BSP	1" 1/4	62	10,5	36	47	13	78	ø41,28x3,53	M10x25	0,9
8KRD010	RD 72,5/45-1"1/2 BSP	1" 1/2	72,5	12,5	45	49	14	89	ø49,20x3,53	M12x30	1,05
8KRD011	RD 92/65-2"1/2 BSP	2" 1/2	92	12,5	65	60	18	114	ø69,85x3,53	M12x40	1,15

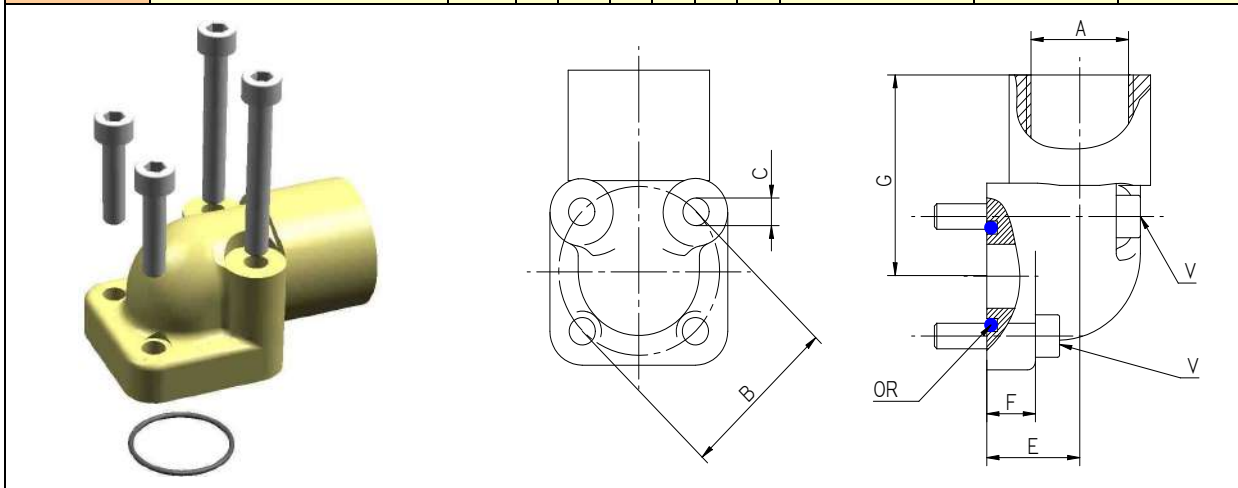

**SQUARED STEEL ELBOWS**

Code	Type	A	B	C	D	E	F	G	OR	V	Weight
									O ring	Screw	
8KRQ001	RQ 30/12-3/8"BSP	3/8"	30	6,5	12	19	11	41	ø15,88x2,61	Nº2 M6x20 Nº2 M6x35	0,29
8KRQ002	RQ 30/12-1/2"BSP	1/2"	30	6,5	12	19	11	41	ø15,88x2,62	Nº2 M6x20 Nº2 M6x35	0,29
8KRQ003	RQ 35/15 -3/8"BSP	3/8"	35	6,5	15	18	11	40	ø18,72x2,62	Nº2 M6x20 Nº2 M6x35	0,34
8KRQ004	RQ 35/15 -1/2"BSP	1/2"	35	6,5	15	18	11	40	ø18,72x2,62	Nº2 M6x20 Nº2 M6x35	0,34
8KRQ005	RQ 40/20-1/2"BSP	1/2"	40	6,5	20	24	10	45	ø22,22x2,62	Nº2 M6x25 Nº2 M6x45	0,4
8KRQ006	RQ 40/20-3/4"BSP	3/4"	40	6,5	20	24	10	45	ø22,22x2,62	Nº2 M6x25 Nº2 M6x45	0,4
8KRQ007	RQ 55/25-3/4"BSP	3/4"	55	8,5	25	35	13	54	ø29,75x3,53	Nº2 M8x25 Nº2 M8x60	0,45
8KRQ008	RQ 55/25-1" BSP	1"	55	8,5	25	35	13	54	ø29,75x3,53	Nº2 M8x25 Nº2 M8x60	0,45

**STRAIGHT STEEL UNIONS**

Code	Type	A	B	C	D	E	F	G	OR	V	Weight
									O ring	Screw	
8KRD003	RD 35/15 (BH)-1/2"BSP	1/2"	35	6,5	14	35	10	40	ø18,72x2,62	M6x20	0,15
8KRD004	RD 40/20 (BH)-3/4"BSP	3/4"	40	6,5	17	35	10	40	ø22,22x2,62	M6x20	0,17

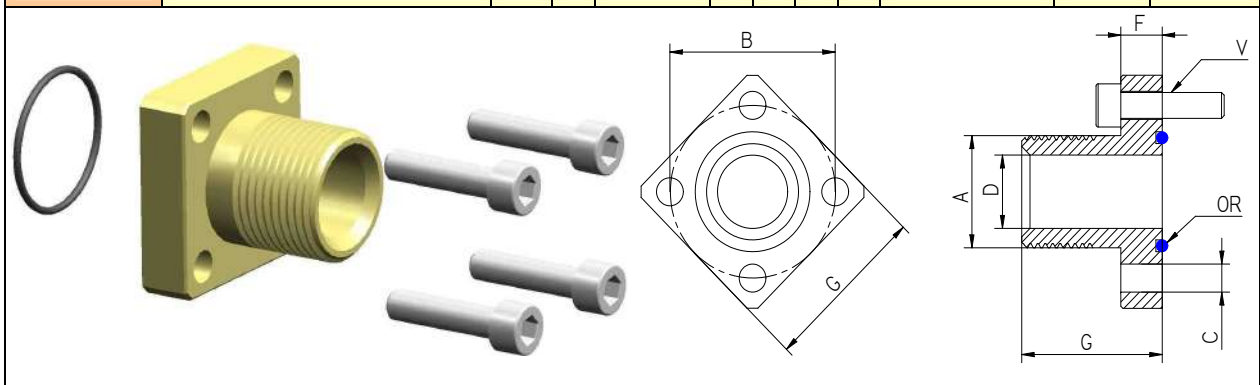

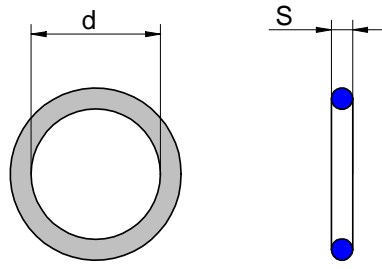
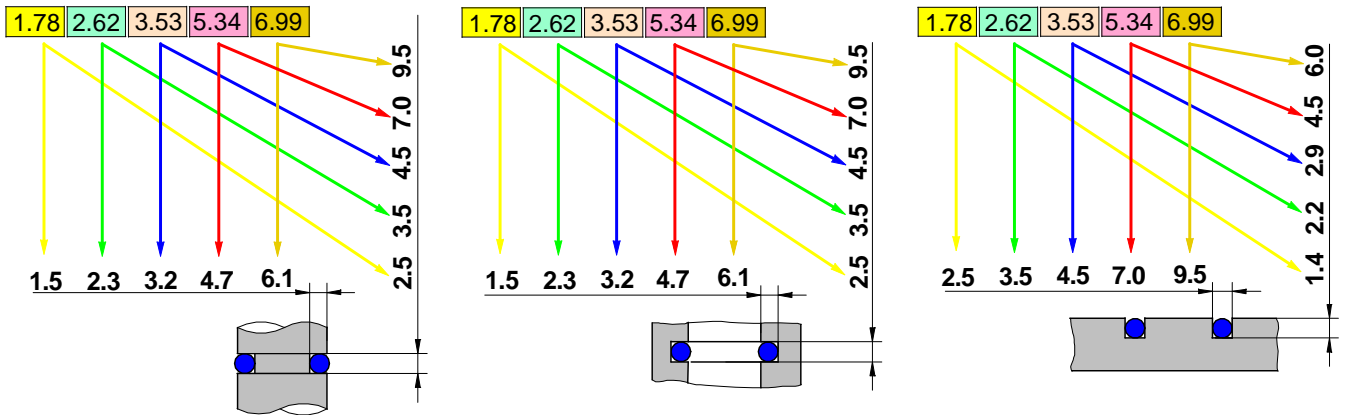

S=1,78		S=2,62				S=3,53				S=5,34				S=6,99		
1,78	33,05	9,13	34,60	82,22	247,33	18,64	52,39	88,50	190,1	37,43	107,2	158,12	481,46	113,7	181,0	342,3
2,57	34,65	9,19	36,14	88,57		20,22	53,37	91,67	196,4	40,65	109,5	164,47	506,86	114,7	183,5	354,9
2,90	37,82	9,92	37,77	94,92		21,82	53,98	94,84	202,8	43,82	110,5	170,82	532,26	116,8	187,3	367,7
3,68	41,00	10,78	39,34	101,27		23,40	55,56	98,02	209,1	47,00	113,7	117,17	557,66	120,0	189,9	380,3
4,47	44,17	11,91	40,95	107,63		24,99	56,74	101,2	215,5	50,16	116,84	183,52	582,68	123,2	193,7	393,1
5,28	47,35	12,37	42,52	113,98		25,80	57,15	104,4	221,8	53,34	117,5	189,87	608,08	124,6	196,2	
6,07	50,52	13,10	44,12	120,33		26,58	58,74	107,5	228,2	56,52	120,02	196,22	633,48	126,4	200,0	
6,75	53,70	13,95	45,69	126,67		28,17	59,92	110,7	234,5	59,69	120,7	202,57	658,88	129,5	202,6	
7,65	56,87	15,08	47,30	133,00		29,75	60,33	113,9	240,9	62,87	123,2	208,92		132,7	208,9	
8,73	60,05	15,54	48,99	139,38		31,34	61,91	117,1	247,2	66,04	123,8	215,27		134,5	215,3	
9,25	63,22	15,88	50,47	145,73		32,93	63,09	120,2	253,6	69,22	126,37	221,62		135,9	221,6	
10,82	66,40	17,13	52,07	152,07		34,52	63,50	123,4	266,3	72,39	127,0	227,97		139,1	227,9	
11,11	69,57	17,86	53,65	158,43		36,10	56,09	126,6	279,0	74,63	129,54	234,32		142,2	234,3	
12,42	72,75	18,72	55,25	164,78		37,89	66,27	129,8	291,7	75,57	130,2	240,67		145,4	240,7	
14,00	75,92	20,29	56,82	171,13		39,69	66,68	132,9	304,4	78,74	132,72	247,02		148,6	247,0	
15,60	82,27	20,63	58,42	177,48		40,89	68,26	136,1	329,8	79,77	133,4	253,37		151,8	253,3	
17,17	88,62	21,89	60,00	183,83		41,28	69,44	139,3	355,2	81,92	135,9	266,07		155,6	259,7	
18,77	94,97	22,22	61,60	190,18		42,86	69,85	142,5	380,6	85,09	136,5	278,77		158,1	266,1	
20,35	101,32	23,47	63,17	196,53		44,04	71,44	145,6	405,2	88,27	139,07	291,5		159,5	272,4	
31,95	107,67	23,81	64,77	202,88		44,45	72,62	148,8	430,6	89,69	139,7	304,17		161,9	278,7	
23,52	114,02	25,07	66,35	209,23		46,04	73,03	152,0	456,0	91,44	142,9	329,57		164,5	285,1	
25,12	120,37	26,65	67,95	215,58		47,22	74,61	158,3		94,62	145,42	354,97		166,7	291,5	
26,70	126,72	28,25	69,52	221,93		47,63	75,80	164,7		97,79	146,1	380,37		168,3	297,8	
28,30	133,07	29,82	71,12	228,28		49,21	78,97	171,0		100,0	148,6	405,26		170,8	304,1	
29,87		31,42	72,69	234,63		50,39	82,14	177,4		101,0	149,2	430,66		174,6	316,9	
31,47		32,99	75,87	240,98		50,80	85,32	183,7		104,1	151,77	456,06		177,2	329,6	

Speed m/sec		Capacities - l/min																			
		5	10	15	20	25	30	35	40	45	50	55	60	65	70	75	80	85	90	95	100
Inlet	0,5	14,6	20,6	25,2	29,1	32,6	35,7	38,5	41,2	43,7	46,0	48,3	50,4	52,5	54,5	56,4	58,2	60,0	61,8	63,5	65,1
	1,0	10,3	14,6	17,8	20,6	23,0	25,2	27,2	29,1	30,9	32,6	34,1	35,7	37,1	38,5	39,9	41,2	42,4	43,7	44,9	46,0
	1,3	9,2	13,0	15,9	18,4	20,6	22,6	24,4	26,0	27,6	29,1	30,5	31,9	33,2	34,5	35,7	36,8	38,0	39,1	40,1	41,2
	1,5	8,4	11,9	14,6	16,8	18,8	20,6	22,2	23,8	25,2	26,6	27,9	29,1	30,3	31,5	32,6	33,6	34,7	35,7	36,6	37,6
Return	1,8	7,8	11,0	13,5	15,6	17,4	19,1	20,6	22,0	23,3	24,6	25,8	27,0	28,1	29,1	30,1	31,1	32,1	33,0	33,9	34,8
	2,0	7,3	10,3	12,6	14,6	16,3	17,8	19,3	20,6	21,8	23,0	24,1	25,2	26,2	27,2	28,2	29,1	30,0	30,9	31,7	32,6
	2,5	6,5	9,2	11,3	13,0	14,6	15,9	17,2	18,4	19,5	20,6	21,6	22,6	23,5	24,4	25,2	26,0	26,8	27,6	28,4	29,1
Outlet	3,0	5,9	8,4	10,3	11,9	13,3	14,6	15,7	16,8	17,8	18,8	19,7	20,6	21,4	22,2	23,0	23,8	24,5	25,2	25,9	26,6
	3,5	5,5	7,8	9,5	11,0	12,3	13,5	14,6	15,6	16,5	17,4	18,3	19,1	19,8	20,6	21,3	22,0	22,7	23,3	24,0	24,6
	4,0	5,1	7,3	8,9	10,3	11,5	12,6	13,6	14,6	15,4	16,3	17,1	17,8	18,6	19,3	19,9	20,6	21,2	21,8	22,4	23,0
	4,5	4,9	6,9	8,4	9,7	10,9	11,9	12,8	13,7	14,6	15,3	16,1	16,8	17,5	18,2	18,8	19,4	20,0	20,6	21,2	21,7
	5,0	4,6	6,5	8,0	9,2	10,3	11,3	12,2	13,0	13,8	14,6	15,3	15,9	16,6	17,2	17,8	18,4	19,0	19,5	20,1	20,6
	5,5	4,4	6,2	7,6	8,8	9,8	10,8	11,6	12,4	13,2	13,9	14,6	15,2	15,8	16,4	17,0	17,6	18,1	18,6	19,1	19,6
	6,0	4,2	5,9	7,3	8,4	9,4	10,3	11,1	11,9	12,6	13,3	13,9	14,6	15,2	15,7	16,3	16,8	17,3	17,8	18,3	18,8
	6,5	4,0	5,7	7,0	8,1	9,0	9,9	10,7	11,4	12,1	12,8	13,4	14,0	14,6	15,1	15,6	16,2	16,7	17,1	17,6	18,1
	7,0	3,9	5,5	6,7	7,8	8,7	9,5	10,3	11,0	11,7	12,3	12,9	13,5	14,0	14,6	15,1	15,6	16,0	16,5	17,0	17,4
	7,5	3,8	5,3	6,5	7,5	8,4	9,2	9,9	10,6	11,3	11,9	12,5	13,0	13,6	14,1	14,6	15,0	15,5	15,9	16,4	16,8
	8,0	3,6	5,1	6,3	7,3	8,1	8,9	9,6	10,3	10,9	11,5	12,1	12,6	13,1	13,6	14,1	14,6	15,0	15,4	15,9	16,3
	8,5	3,5	5,0	6,1	7,1	7,9	8,7	9,3	10,0	10,6	11,2	11,7	12,2	12,7	13,2	13,7	14,1	14,6	15,0	15,4	15,8
	9,0	3,4	4,9	5,9	6,9	7,7	8,4	9,1	9,7	10,3	10,9	11,4	11,9	12,4	12,8	13,3	13,7	14,1	14,6	15,0	15,3
	9,5	3,3	4,7	5,8	6,7	7,5	8,2	8,8	9,4	10,0	10,6	11,1	11,6	12,0	12,5	12,9	13,4	13,8	14,2	14,6	14,9
10,0	3,3	4,6	5,6	6,5	7,3	8,0	8,6	9,2	9,8	10,3	10,8	11,3	11,7	12,2	12,6	13,0	13,4	13,8	14,2	14,6	
Speed m/sec	Inner pipe diameter - mm																				

Speed m/sec		Capacities - l/min																			
		110	120	130	140	150	160	170	180	190	200	210	220	230	240	250	260	270	280	290	300
Inlet	0,5	68,3	71,3	74,2	77,0	79,7	82,4	84,9	87,4	89,8	92,1	94,4	96,6	98,8	100,9	103,0	105,0	107,0	109,0	110,9	112,8
	1,0	48,3	50,4	52,5	54,5	56,4	58,2	60,0	61,8	63,5	65,1	66,7	68,3	69,8	71,3	72,8	74,2	75,7	77,0	78,4	79,7
	1,3	43,2	45,1	47,0	48,7	50,4	52,1	53,7	55,3	56,8	58,2	59,7	61,1	62,5	63,8	65,1	66,4	67,7	68,9	70,1	71,3
	1,5	39,4	41,2	42,9	44,5	46,0	47,6	49,0	50,4	51,8	53,2	54,5	55,8	57,0	58,2	59,4	60,6	61,8	62,9	64,0	65,1
Return	1,8	36,5	38,1	39,7	41,2	42,6	44,0	45,4	46,7	48,0	49,2	50,4	51,6	52,8	53,9	55,0	56,1	57,2	58,2	59,3	60,3
	2,0	34,1	35,7	37,1	38,5	39,9	41,2	42,4	43,7	44,9	46,0	47,2	48,3	49,4	50,4	51,5	52,5	53,5	54,5	55,4	56,4
	2,5	30,5	31,9	33,2	34,5	35,7	36,8	38,0	39,1	40,1	41,2	42,2	43,2	44,2	45,1	46,0	47,0	47,8	48,7	49,6	50,4
Outlet	3,0	27,9	29,1	30,3	31,5	32,6	33,6	34,7	35,7	36,6	37,6	38,5	39,4	40,3	41,2	42,0	42,9	43,7	44,5	45,3	46,0
	3,5	25,8	27,0	28,1	29,1	30,1	31,1	32,1	33,0	33,9	34,8	35,7	36,5	37,3	38,1	38,9	39,7	40,4	41,2	41,9	42,6
	4,0	24,1	25,2	26,2	27,2	28,2	29,1	30,0	30,9	31,7	32,6	33,4	34,1	34,9	35,7	36,4	37,1	37,8	38,5	39,2	39,9
	4,5	22,8	23,8	24,7	25,7	26,6	27,5	28,3	29,1	29,9	30,7	31,5	32,2	32,9	33,6	34,3	35,0	35,7	36,3	37,0	37,6
	5,0	21,6	22,6	23,5	24,4	25,2	26,0	26,8	27,6	28,4	29,1	29,8	30,5	31,2	31,9	32,6	33,2	33,8	34,5	35,1	35,7
	5,5	20,6	21,5	22,4	23,2	24,0	24,8	25,6	26,3	27,1	27,8	28,5	29,1	29,8	30,4	31,0	31,7	32,3	32,9	33,4	34,0
	6,0	19,7	20,6	21,4	22,2	23,0	23,8	24,5	25,2	25,9	26,6	27,2	27,9	28,5	29,1	29,7	30,3	30,9	31,5	32,0	32,6
	6,5	18,9	19,8	20,6	21,4	22,1	22,8	23,5	24,2	24,9	25,5	26,2	26,8	27,4	28,0	28,6	29,1	29,7	30,2	30,8	31,3
	7,0	18,3	19,1	19,8	20,6	21,3	22,0	22,7	23,3	24,0	24,6	25,2	25,8	26,4	27,0	27,5	28,1	28,6	29,1	29,6	30,1
	7,5	17,6	18,4	19,2	19,9	20,6	21,3	21,9	22,6	23,2	23,8	24,4	24,9	25,5	26,0	26,6	27,1	27,6	28,1	28,6	29,1
	8,0	17,1	17,8	18,6	19,3	19,9	20,6	21,2	21,8	22,4	23,0	23,6	24,1	24,7	25,2	25,7	26,2	26,7	27,2	27,7	28,2
	8,5	16,6	17,3	18,0	18,7	19,3	20,0	20,6	21,2	21,8	22,3	22,9	23,4	24,0	24,5	25,0	25,5	26,0	26,4	26,9	27,4
	9,0	16,1	16,8	17,5	18,2	18,8	19,4	20,0	20,6	21,2	21,7	22,2	22,8	23,3	23,8	24,3	24,7	25,2	25,7	26,1	26,6
	9,5	15,7	16,4	17,0	17,7	18,3	18,9	19,5	20,0	20,6	21,1	21,6	22,2	22,7	23,1	23,6	24,1	24,5	25,0	25,4	25,9
10,0	15,3	15,9	16,6	17,2	17,8	18,4	19,0	19,5	20,1	20,6	21,1	21,6	22,1	22,6	23,0	23,5	23,9	24,4	24,8	25,2	
Speed m/sec	Inner pipe diameter - mm																				

Speed m/sec	Capacities - l/min																				
	320	340	360	380	400	420	440	460	480	500	520	540	560	580	600	620	640	660	680	700	
Inlet	0,5	116,5	120,1	123,5	126,9	130,2	133,4	136,6	139,7	142,7	145,6	148,5	151,3	154,1	156,8	159,5	162,1	164,7	167,3	169,8	172,3
	1,0	82,4	84,9	87,4	89,8	92,1	94,4	96,6	98,8	100,9	103,0	105,0	107,0	109,0	110,9	112,8	114,6	116,5	118,3	120,1	121,8
	1,3	73,7	75,9	78,1	80,3	82,4	84,4	86,4	88,3	90,2	92,1	93,9	95,7	97,5	99,2	100,9	102,5	104,2	105,8	107,4	109,0
	1,5	67,3	69,3	71,3	73,3	75,2	77,0	78,9	80,6	82,4	84,1	85,7	87,4	89,0	90,5	92,1	93,6	95,1	96,6	98,0	99,5
Return	1,8	62,3	64,2	66,0	67,8	69,6	71,3	73,0	74,6	76,3	77,8	79,4	80,9	82,4	83,8	85,3	86,7	88,1	89,4	90,8	92,1
	2,0	58,2	60,0	61,8	63,5	65,1	66,7	68,3	69,8	71,3	72,8	74,2	75,7	77,0	78,4	79,7	81,1	82,4	83,6	84,9	86,1
	2,5	52,1	53,7	55,3	56,8	58,2	59,7	61,1	62,5	63,8	65,1	66,4	67,7	68,9	70,1	71,3	72,5	73,7	74,8	75,9	77,0
Outlet	3,0	47,6	49,0	50,4	51,8	53,2	54,5	55,8	57,0	58,2	59,4	60,6	61,8	62,9	64,0	65,1	66,2	67,3	68,3	69,3	70,3
	3,5	44,0	45,4	46,7	48,0	49,2	50,4	51,6	52,8	53,9	55,0	56,1	57,2	58,2	59,3	60,3	61,3	62,3	63,2	64,2	65,1
	4,0	41,2	42,4	43,7	44,9	46,0	47,2	48,3	49,4	50,4	51,5	52,5	53,5	54,5	55,4	56,4	57,3	58,2	59,1	60,0	60,9
	4,5	38,8	40,0	41,2	42,3	43,4	44,5	45,5	46,6	47,6	48,5	49,5	50,4	51,4	52,3	53,2	54,0	54,9	55,8	56,6	57,4
	5,0	36,8	38,0	39,1	40,1	41,2	42,2	43,2	44,2	45,1	46,0	47,0	47,8	48,7	49,6	50,4	51,3	52,1	52,9	53,7	54,5
	5,5	35,1	36,2	37,3	38,3	39,3	40,2	41,2	42,1	43,0	43,9	44,8	45,6	46,5	47,3	48,1	48,9	49,7	50,4	51,2	51,9
	6,0	33,6	34,7	35,7	36,6	37,6	38,5	39,4	40,3	41,2	42,0	42,9	43,7	44,5	45,3	46,0	46,8	47,6	48,3	49,0	49,7
	6,5	32,3	33,3	34,3	35,2	36,1	37,0	37,9	38,7	39,6	40,4	41,2	42,0	42,7	43,5	44,2	45,0	45,7	46,4	47,1	47,8
	7,0	31,1	32,1	33,0	33,9	34,8	35,7	36,5	37,3	38,1	38,9	39,7	40,4	41,2	41,9	42,6	43,3	44,0	44,7	45,4	46,0
	7,5	30,1	31,0	31,9	32,8	33,6	34,5	35,3	36,1	36,8	37,6	38,3	39,1	39,8	40,5	41,2	41,9	42,5	43,2	43,8	44,5
	8,0	29,1	30,0	30,9	31,7	32,6	33,4	34,1	34,9	35,7	36,4	37,1	37,8	38,5	39,2	39,9	40,5	41,2	41,8	42,4	43,1
	8,5	28,3	29,1	30,0	30,8	31,6	32,4	33,1	33,9	34,6	35,3	36,0	36,7	37,4	38,0	38,7	39,3	40,0	40,6	41,2	41,8
	9,0	27,5	28,3	29,1	29,9	30,7	31,5	32,2	32,9	33,6	34,3	35,0	35,7	36,3	37,0	37,6	38,2	38,8	39,4	40,0	40,6
9,5	26,7	27,5	28,3	29,1	29,9	30,6	31,3	32,0	32,7	33,4	34,1	34,7	35,4	36,0	36,6	37,2	37,8	38,4	39,0	39,5	
10,0	26,0	26,8	27,6	28,4	29,1	29,8	30,5	31,2	31,9	32,6	33,2	33,8	34,5	35,1	35,7	36,3	36,8	37,4	38,0	38,5	
Speed m/sec	Inner pipe diameter - mm																				

$d =$ Inner pipe diameter [mm]	$d = \sqrt{\frac{Q \cdot 21.2}{V}} [mm] \quad V = \frac{Q \cdot 21.2}{d^2} [m/sec] \quad Q = \frac{d^2 \cdot V}{21.2} [l/min]$
$Q =$ Capacities [ l ]	
$V =$ Speed [m/sec ]	

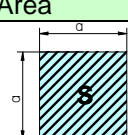
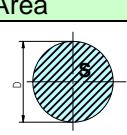
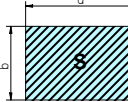
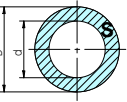
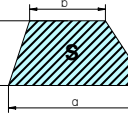
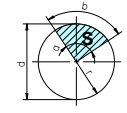
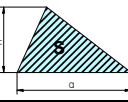
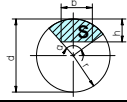
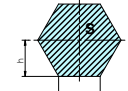
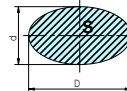
Table of Areas and Perimeters			
S= Area	S= Area	S= Area	
	$S = a^2$ $P = a \times 4$		$S = \pi/4 \times D^2$ $P = \pi \times D$
	$S = a \times b$ $P = 2(a + b)$		$S = \pi/4 \times (D^2 - d^2)$
	$S = (a + b) \times h/2$		$S = \pi \times r^2 \times \alpha / 360^\circ$ $b = \pi \times \alpha \times d / 360^\circ$
	$S = a \times h/2$		$S = (\pi r^2 \alpha / 360^\circ) - (b \times (r - h) / 2)$
	$S = 3 \times a \times h$		$S = \pi/4 \times D \times d$

Mpa	bar	Kg/cm <sup>2</sup>	PSI	bar	Mpa	Kg/cm <sup>2</sup>	PSI	Kg/cm <sup>2</sup>	Mpa	bar	PSI	PSI	Mpa	bar	Kg/cm <sup>2</sup>
1	10	10,19	145,14	1	0,1	1,019	14,5	1	0,902	0,981	14,22	1	0,007	0,069	0,0703
2	20	20,38	290,28	2	0,2	2,038	29	2	1,902	1,962	28,44	2	0,014	0,138	0,1406
3	30	30,57	435,42	3	0,3	3,057	43,5	3	2,902	2,943	42,66	3	0,021	0,207	0,2109
4	40	40,76	580,56	4	0,4	4,076	58	4	3,902	3,924	56,88	4	0,028	0,276	0,2812
5	50	50,95	725,7	5	0,5	5,095	72,5	5	4,902	4,905	71,1	5	0,035	0,345	0,3515
6	60	61,14	870,84	6	0,6	6,114	87	6	5,902	5,886	85,32	6	0,042	0,414	0,4218
7	70	71,33	1016	7	0,7	7,133	101,5	7	6,902	6,867	99,54	7	0,049	0,483	0,4921
8	80	81,52	1161,1	8	0,8	8,152	116	8	7,902	7,848	113,76	8	0,056	0,552	0,5624
9	90	91,71	1306,3	9	0,9	9,171	130,5	9	8,902	8,829	127,98	9	0,063	0,621	0,6327
10	100	101,9	1451,4	10	1	10,19	145	10	9,902	9,81	142,2	10	0,07	0,69	0,703
20	200	203,8	2902,8	20	2	20,38	290	20	19,902	19,62	284,4	20	0,14	1,38	1,406
30	300	305,7	4354,2	30	3	30,57	435	30	29,902	29,43	426,6	30	0,21	2,07	2,109
40	400	407,6	5805,6	40	4	40,76	580	40	39,902	39,24	568,8	40	0,28	2,76	2,812
50	500	509,5	7257	50	5	50,95	725	50	49,902	49,05	711	50	0,35	3,45	3,515
60	600	611,4	8708,4	60	6	61,14	870	60	59,902	58,86	853,2	60	0,42	4,14	4,218
70	700	713,3	10160	70	7	71,33	1015	70	69,902	68,67	995,4	70	0,49	4,83	4,921
80	800	815,2	11611	80	8	81,52	1160	80	79,902	78,48	1137,6	80	0,56	5,52	5,624
90	900	917,1	13063	90	9	91,71	1305	90	89,902	88,29	1279,8	90	0,63	6,21	6,327
100	1000	1019	14514	100	10	101,9	1450	100	99,902	98,1	1422	100	0,7	6,9	7,03
110	1100	1120,9	15965	110	11	112,09	1595	110	109,9	107,91	1564,2	110	0,77	7,59	7,733
120	1200	1222,8	17417	120	12	122,28	1740	120	119,9	117,72	1706,4	120	0,84	8,28	8,436
130	1300	1324,7	18868	130	13	132,47	1885	130	129,9	127,53	1848,6	130	0,91	8,97	9,139
140	1400	1426,6	20320	140	14	142,66	2030	140	139,9	137,34	1990,8	140	0,98	9,66	9,842
150	1500	1528,5	21771	150	15	152,85	2175	150	149,9	147,15	2133	150	1,05	10,35	10,545
160	1600	1630,4	23222	160	16	163,04	2320	160	159,9	156,96	2275,2	160	1,12	11,04	11,248
170	1700	1732,3	24674	170	17	173,23	2465	170	169,9	166,77	2417,4	170	1,19	11,73	11,951
180	1800	1834,2	26125	180	18	183,42	2610	180	179,9	176,58	2559,6	180	1,26	12,42	12,654
190	1900	1936,1	27577	190	19	193,61	2755	190	189,9	186,39	2701,8	190	1,33	13,11	13,357
200	2000	2038	29028	200	20	203,8	2900	200	199,9	196,2	2844	200	1,4	13,8	14,06
210	2100	2139,9	30479	210	21	213,99	3045	210	209,9	206,01	2986,2	210	1,47	14,49	14,763
220	2200	2241,8	31931	220	22	224,18	3190	220	219,9	215,82	3128,4	220	1,54	15,18	15,466
230	2300	2343,7	33382	230	23	234,37	3335	230	229,9	225,63	3270,6	230	1,61	15,87	16,169
240	2400	2445,6	34834	240	24	244,56	3480	240	239,9	235,44	3412,8	240	1,68	16,56	16,872
250	2500	2547,5	36285	250	25	254,75	3625	250	249,9	245,25	3555	250	1,75	17,25	17,575
260	2600	2649,4	37736	260	26	264,94	3770	260	259,9	255,06	3697,2	260	1,82	17,94	18,278
270	2700	2751,3	39188	270	27	275,13	3915	270	269,9	264,87	3839,4	270	1,89	18,63	18,981
280	2800	2853,2	40639	280	28	285,32	4060	280	279,9	274,68	3981,6	280	1,96	19,32	19,684
290	2900	2955,1	42091	290	29	295,51	4205	290	289,9	284,49	4123,8	290	2,03	20,01	20,387
300	3000	3057	43542	300	30	305,7	4350	300	299,9	294,3	4266	300	2,1	20,7	21,09
310	3100	3158,9	44993	310	31	315,89	4495	310	309,9	304,11	4408,2	310	2,17	21,39	21,793
320	3200	3260,8	46445	320	32	326,08	4640	320	319,9	313,92	4550,4	320	2,24	22,08	22,496
330	3300	3362,7	47896	330	33	336,27	4785	330	329,9	323,73	4692,6	330	2,31	22,77	23,199
340	3400	3464,6	49348	340	34	346,46	4930	340	339,9	333,54	4834,8	340	2,38	23,46	23,902
350	3500	3566,5	50799	350	35	356,65	5075	350	349,9	343,35	4977	350	2,45	24,15	24,605
Mpa= 0,1 bar Mpa= 0,098 Kg/cm <sup>2</sup> Mpa= 0,007 PSI				bar= 10 MPa bar= 0,981 Kg/cm <sup>2</sup> bar= 0,069 PSI				Kg/cm <sup>2</sup> = 10,19 MPa Kg/cm <sup>2</sup> = 1,019 bar Kg/cm <sup>2</sup> = 0,0703 PSI				PSI= 145,14 MPa PSI= 14,5 bar PSI= 14,22 kg/cm <sup>2</sup>			

Inches -> Millimetres 1Poll. = 25,40 mm							
in	mm	in	mm	in	mm	in	mm
1/64	0,397	1 1/2	38,1	15	381	36	914,4
1/32	0,764	1 3/4	44,45	16	406,4	38	965,2
3/64	1,191	2	50,8	17	431,8	40	1016
1/16	1,588	2 1/2	63,5	18	457,2	42	1066,8
3/32	2,381	3	76,2	19	482,6	44	1117,6
1/8	3,175	3 1/2	88,9	20	508	46	1168,4
5/32	3,969	4	101,6	21	533,4	48	1219,2
3/16	4,763	4 1/2	114,3	22	558,8	50	1270
1/4	6,35	5	127	23	584,2	55	1397
5/16	7,938	6	152,4	24	609,6	60	1524
3/8	9,525	7	177,8	25	635	65	1651
7/16	11,11	8	203,2	26	660,4	70	1778
1/2	12,7	9	228,6	27	685,8	75	1905
5/8	15,88	10	254	28	711,2	80	2032
3/4	19,05	11	279,4	29	736,6	85	2159
7/8	22,23	12	304,8	30	762	90	2286
1	25,4	13	330,2	32	812,8	95	2413
1 1/4	31,75	14	355,6	34	863,6	100	2540

Millimetres -> Inches 1 mm = 0,03937008 pollici							
mm	in	mm	in	mm	in	mm	in
1	0,039	28	1,102	130	5,12	750	29,53
2	0,079	30	1,181	140	5,51	800	31,50
3	0,118	35	1,378	150	5,91	850	33,46
4	0,157	40	1,575	160	6,30	900	35,43
5	0,197	45	1,772	170	6,69	950	37,40
6	0,236	50	1,969	180	7,09	1000	39,37
7	0,276	55	2,165	190	7,48	1250	49,21
8	0,315	60	2,362	200	7,87	1500	59,06
9	0,354	65	2,559	250	9,84	1750	68,90
10	0,394	70	2,756	300	11,81	2000	78,74
11	0,433	75	2,953	350	13,78	2500	98,43
12	0,472	80	3,150	400	15,75	3000	118,11
14	0,551	85	3,346	450	17,72	3500	137,80
16	0,630	90	3,543	500	19,69	4000	157,48
18	0,709	95	3,740	550	21,65	4500	177,17
20	0,787	100	3,937	600	23,62	5000	196,85
22	0,866	110	4,331	650	25,59	7500	295,28
26	1,024	120	4,724	700	27,56	10000	393,70

US Gallons -> Litres 1gallone = 3,785334 litri							
gal.	litri	gal.	litri	gal.	litri	gal.	litri
1	3,79	10	37,85	100	378,5	500	1893
2	7,57	20	75,71	120	454,2	600	2271
3	11,36	30	113,6	140	529,9	700	2650
4	15,14	40	151,4	160	605,7	800	3028
5	18,93	50	189,3	180	681,4	900	3407
6	22,71	60	227,1	200	757,1	1000	3785
7	26,50	70	265,0	250	946,3	1500	5678
8	30,28	80	302,8	300	1136	2000	7571
9	34,07	90	340,7	400	1514	3000	11356

Litres -> US Gallons 1litro = 0,2641775 galloni							
litri	gal.	litri	gal.	litri	gal.	litri	gal.
1	0,264	10	2,642	300	79,25	3000	792,5
2	0,528	20	5,284	400	105,7	4000	1057
3	0,793	30	7,925	500	132,1	5000	1321
4	1,057	40	10,57	600	158,5	6000	1585
5	1,321	50	13,21	700	184,9	8000	2113
6	1,585	100	26,42	800	211,3	10000	2642
7	1,849	150	39,63	900	237,8	20000	5284
8	2,113	200	52,84	1000	264,2	30000	7925
9	2,378	250	66,04	2000	528,4	50000	13209

Horsepower => Kilowatts 1 CV = 0,735 kW							
CV	Kw	CV	Kw	CV	Kw	CV	Kw
1	0,74	9	6,62	24	17,64	60	44,10
2	1,47	10	7,35	26	19,11	70	51,45
3	2,21	12	8,82	28	20,58	80	58,80
4	2,94	14	10,29	30	22,05	90	66,15
5	3,68	16	11,76	35	25,73	100	73,50
6	4,41	18	13,23	40	29,40	150	110,25
7	5,15	20	14,70	45	33,08	200	147,00
8	5,88	22	16,17	50	36,75	300	220,50

Kilowatts=>Horsepower 1 kW = 1,36 CV							
Kw	CV	Kw	CV	Kw	CV	Kw	CV
1	1,36	9	12,24	24	32,64	60	81,6
2	2,72	10	13,6	26	35,36	70	95,2
3	4,08	12	16,32	28	38,08	80	108,8
4	5,44	14	19,04	30	40,8	90	122,4
5	6,8	16	21,76	35	47,6	100	136
6	8,16	18	24,48	40	54,4	150	204
7	9,52	20	27,2	45	61,2	200	272
8	10,88	22	29,92	50	68	300	408

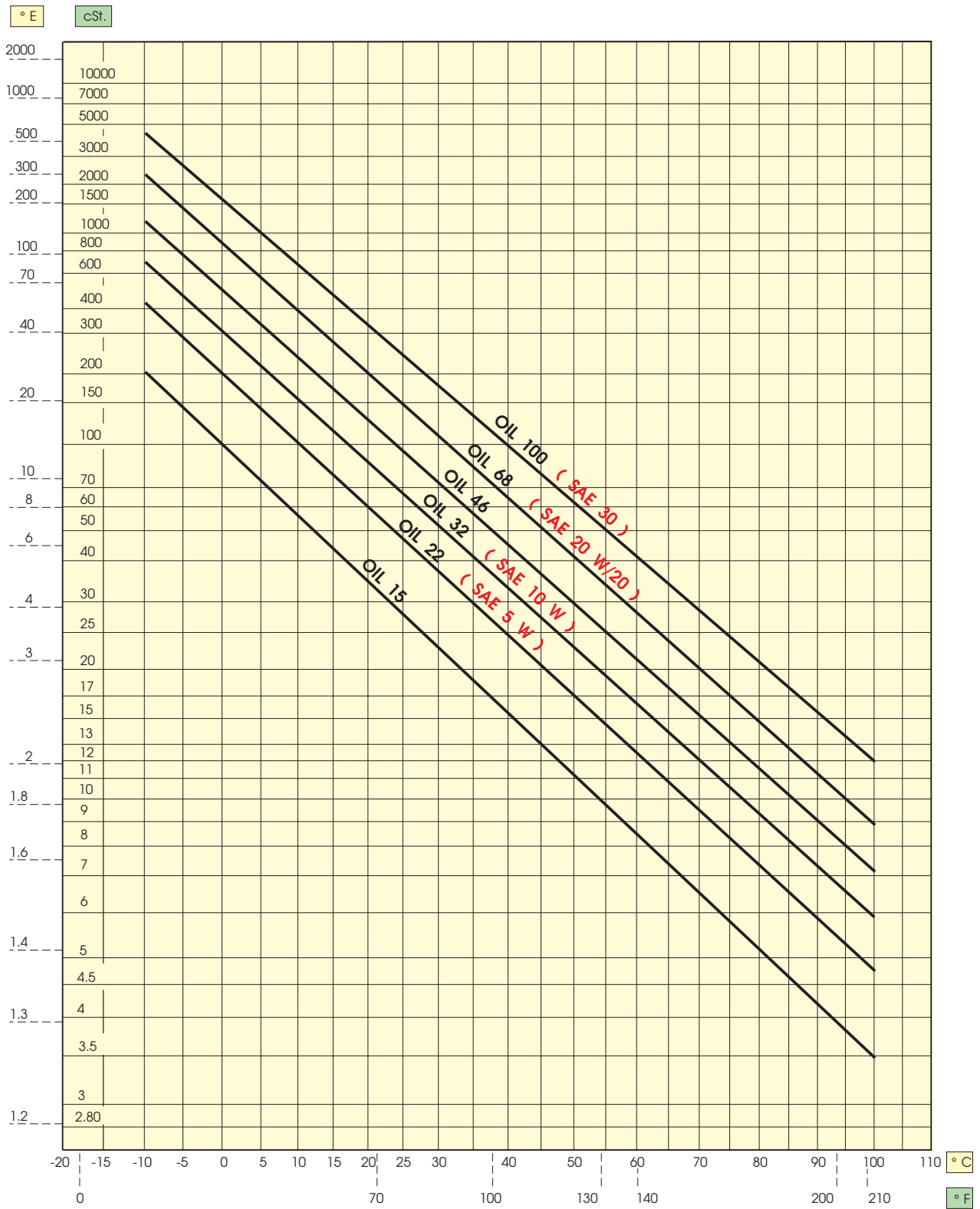



## Table of pressure drops

Note: based on the oil viscosity and capacity of a pump it is possible to determine the pressure drop for every 100 m of piping by means of the table.

On the viscosity, flow rate and internal pipe diameter scales, fix the corresponding values **V**, **Q** and **D**.

Join points **V** and **Q** with a straight line intersecting point **I** on the "index" line.

From this point **I**, pass a straight line through **D** until meeting the pressure drop scale at point **P**; the corresponding value represents the pressure drop at point **P**; the corresponding value represents the pressure drop along 100 m of piping.

EXAMPLE: a pipe through which a fluid having a viscosity of 150 cSt. flows at a rate of 200 l/min and which has a diameter of 40 mm will have a pressure drop of 1 kg/cm<sup>2</sup> for every 100 m of length.

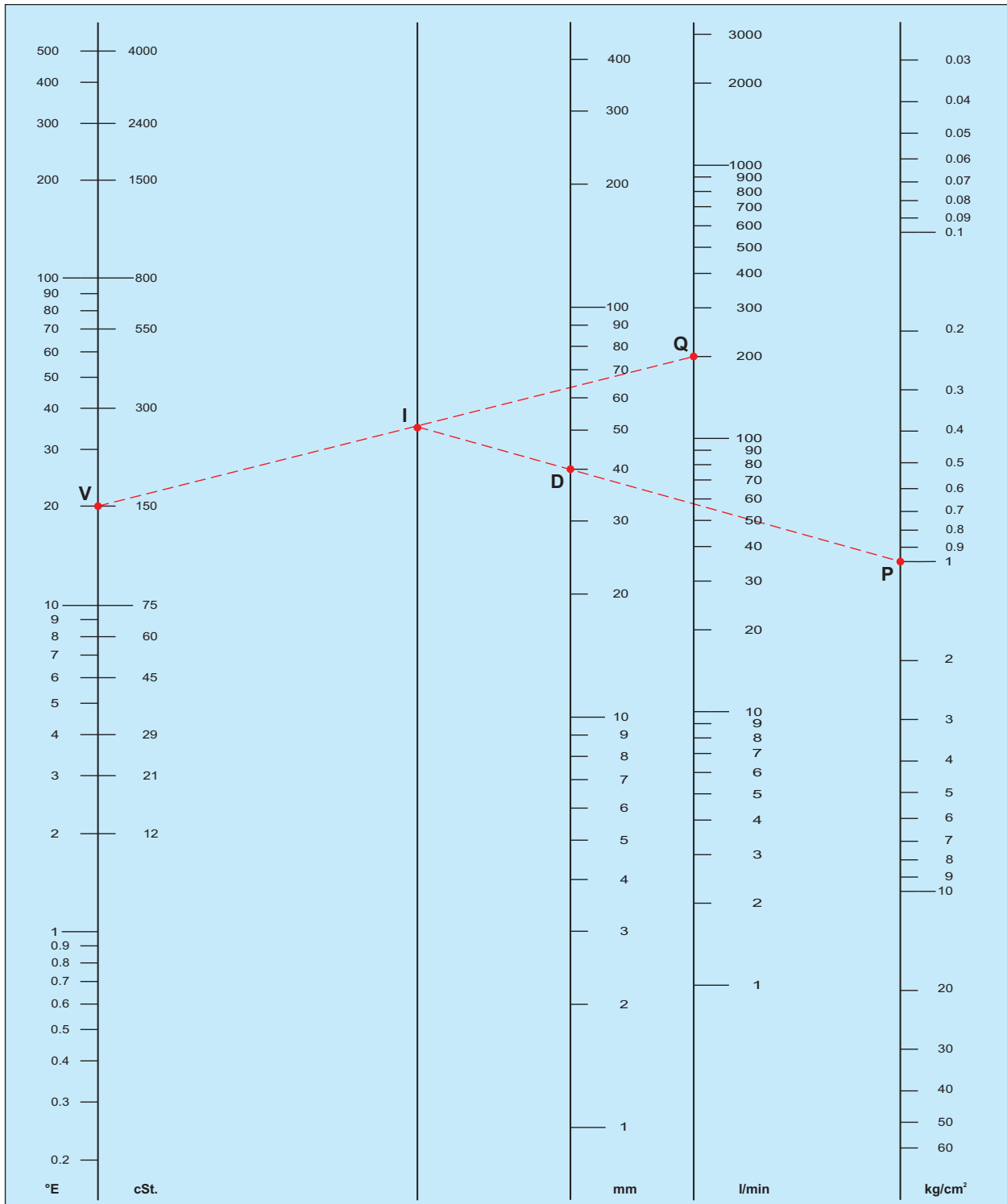

**V**= Viscosity cSt -°E

**I**= Index line of intersection

**D**= Internal pipe diameter in mm

**Q**= Flow rate in l/min

**P**= Pressure drop kg/cm<sup>2</sup> per 100 m

## Table of elements

Element	Symbol	Atomic N°	Atom. Wgt.	Melt. point °C
Hafnium	Hf	72	178,49	2150,00
Aluminium	Al	13	26,98	660,37
Americium	Am	95	243,00	994,00
Antimony	Sb	51	121,75	630,00
Silver	Ag	47	107,87	961,93
Argon	Ar	18	39,95	-189,30
Arsenic	As	33	74,92	817,00
Astetina	At	85	210,00	302,00
Actinium	Ac	89	227,00	1050,00
Nitrogen	N	7	14,01	-209,90
Barium	Ba	56	137,33	725,00
Beryllium	Be	4	9,01	1278,00
Berkelium	Bk	97	247,00	
Bismuth	Bi	83	208,98	271,30
Boron	B	5	10,81	2300,00
Bromine	Br	35	79,90	-7,20
Cadmium	Cd	48	112,41	320,90
Calcium	Ca	20	40,08	839,00
Californium	Cf	98	251,00	
Carbon	C	6	12,01	3500,00
Cerium	Ce	58	140,12	795,00
Cesium	Cs	55	132,91	28,50
Chlorine	Cl	17	35,45	-100,98
Cobalt	Co	27	58,93	1495,00
Krypton	Kr	36	83,80	-157,20
Chromium	Cr	24	52,00	1857,00
Curium	Cm	96	247,00	1340,00
Dysprosium	Dy	66	162,50	1412,00
Einsteinium	Es	99	254,00	
Helium	He	2	4,00	-272,00
Erbium	Er	68	167,26	1522,00
Europium	Eu	63	151,96	822,00
Fermium	Fm	100	257,00	
Iron	Fe	26	55,85	1535,00

Element	Symbol	Atomic N°	Atom. Wgt.	Melt. point °C
Fluorine	F	9	19,00	-219,62
Phosphorus	P	15	30,97	44,10
Francium	Fr	87	223,00	27,00
Gadolinium	Gd	64	157,25	1311,00
Gallium	Ga	31	69,74	29,78
Germanium	Ge	32	72,59	937,40
Hydrogen	H	1	1,01	-259,14
Indium	In	49	114,82	156,61
Iodine	I	53	126,90	113,50
Iridium	Ir	77	192,22	2410,00
Ytterbium	Yb	70	173,04	824,00
Yttrium	Y	39	88,91	1523,00
Lanthanum	La	57	138,91	920,00
Lithium	Li	3	6,94	180,54
Lutetium	Lu	71	174,96	1656,00
Magnesium	Mg	12	24,31	638,80
Manganese	Mn	25	54,94	1245,00
Mendelevium	Md	101	258,00	
Mercury	Hg	80	200,59	-38,87
Molybdenum	Mo	42	95,94	2617,00
Neodymium	Nd	60	144,24	1010,00
Neon	Ne	10	20,17	-248,60
Neptunium	Np	93	237,05	640,00
Nickel	Ni	28	58,71	1453,00
Niobium	Nb	41	92,91	2468,00
Nobelium	No	102	259,00	
Holmium	Ho	67	164,93	1470,00
Gold	Au	79	196,97	1064,43
Osmium	Os	76	190,20	3045,00
Oxygen	O	8	16,00	-218,40
Palladium	Pd	46	106,40	1552,00
Lead	Pb	82	207,20	327,50
Platinum	Pt	78	195,09	1772,00
Plutonium	Pu	94	244,00	639,50

Element	Symbol	Atomic N°	Atom. Wgt.	Melt. point °C
Polonium	Po	84	209,00	254,00
Potassium	K	19	39,10	63,65
Praseodymium	Pr	59	140,91	935,00
Promethium	Pm	61	145,00	
Protactinium	Pa	91	231,04	1600,00
Radium	Ra	88	226,03	700,00
Radon	Rn	86	222,00	-71,00
Copper	Cu	29	63,55	1083,00
Rhenium	Re	75	186,21	3180,00
Rhodium	Rh	45	102,91	1966,00
Rubidium	Rb	37	85,47	38,89
Ruthenium	Ru	44	101,07	2250,00
Samarium	Sm	62	150,40	1072,00
Scandium	Sc	21	44,96	1539,00
Selenium	Se	34	78,96	217,00
Silicon	Si	14	28,09	1410,00
Sodium	Na	11	22,99	97,80
Tin	Sn	50	118,69	231,90
Strontium	Sr	38	87,62	769,00
Thallium	Tl	81	204,37	303,50
Tantalum	Ta	73	180,95	2996,00
Technetium	Tc	43	98,91	2200,00
Tellurium	Te	52	127,60	449,50
Terbium	Tb	65	158,93	1360,00
Titanium	Ti	22	47,90	1660,00
Thorium	Th	90	232,04	1750,00
Thulium	Tm	69	168,93	1545,00
Tungsten	W	74	183,85	3410,00
Uranium	U	92	238,03	1132,00
Vanadium	V	23	50,94	1890,00
Xenon	Xe	54	131,30	-111,90
Zinc	Zn	30	65,38	419,58
Zirconium	Zr	40	91,22	1852,00
Sulfur	S	16	32,06	112,80

## Specific weight of some substances

SOLIDS	
Aluminium	2,70
Silver	10,50
Diamond	8,51
Pure Iron	7,86
Cast Iron	7,27
Nickel	8,85
Gold	19,33
Brass	8,65
Lead	11,34
Platinum	21,45
Plexiglass	1,18
Copper	8,93

LIQUIDS	
Distilled water	1,00
Ethyl alcohol	0,79
Gasoline	0,68
Mercury	13,60
Linseed Oil	0,93
Petroleum	0,81

GASES	
Acetylene	1,10
Ammonia	0,77
Carbon Dioxide	1,98
Air	1,29
Nitrogen	1,25
Helium	0,18
Ethylene	1,26
Hydrogen	0,09
Methane	0,72
Oxygen	1,43

Class	Behaviour	Effects on Physical Properties	Increase in Volume %	delta Sh.A
●	recommended	small or none	less than 10	less than 10
●	satisfactory	minor	from 10 to 30	from 10 to 20
●	unsatisfactory	moderate	from 30 to 60	from 20 to 30
●	not recommended	severe	greater than 60	greater than 30

- NR** = NATURAL RUBBER
- SBR** = STYRENE-BUTADIENE RUBBER
- EPDM** = ETHYLENE-PROPYLENE THERMOPOLYMER
- NBR** = NITRILE RUBBER
- CR** = POLYCHLOROPRENE
- CSM** = CHLOROSULPHONATED POLYETHYLENE
- VMQ** = SILICONE RUBBER
- FKM** = FLUOROCARBON RUBBER (VITON®)

Acetylene	-	● ● ● ● ● ● ● ●	● ● ● ● ● ● ● ●
Acetophenone	-	● ● ● ● ● ● ● ●	● ● ● ● ● ● ● ●
Acetone	-	● ● ● ● ● ● ● ●	● ● ● ● ● ● ● ●
Acetic Acid	10	● ● ● ● ● ● ● ●	● ● ● ● ● ● ● ●
Acetic Acid	50	● ● ● ● ● ● ● ●	● ● ● ● ● ● ● ●
Acetic Acid	25	● ● ● ● ● ● ● ●	● ● ● ● ● ● ● ●
Acetic Acid	100	● ● ● ● ● ● ● ●	● ● ● ● ● ● ● ●
Boric Acid	10	● ● ● ● ● ● ● ●	● ● ● ● ● ● ● ●
Citric Acid	SAT	● ● ● ● ● ● ● ●	● ● ● ● ● ● ● ●
Chloroacetic Acid	-	● ● ● ● ● ● ● ●	● ● ● ● ● ● ● ●
Chromic Acid	40	● ● ● ● ● ● ● ●	● ● ● ● ● ● ● ●
Formic Acid	SAT.	● ● ● ● ● ● ● ●	● ● ● ● ● ● ● ●
Formic Acid	SAT	● ● ● ● ● ● ● ●	● ● ● ● ● ● ● ●
Phosphoric Acid	60	● ● ● ● ● ● ● ●	● ● ● ● ● ● ● ●
Hypochlorous Acid	-	● ● ● ● ● ● ● ●	● ● ● ● ● ● ● ●
Lactic Acid	-	● ● ● ● ● ● ● ●	● ● ● ● ● ● ● ●
Maleic Acid	-	● ● ● ● ● ● ● ●	● ● ● ● ● ● ● ●
Naphthenic Acid	-	● ● ● ● ● ● ● ●	● ● ● ● ● ● ● ●
Nitric Acid	10	● ● ● ● ● ● ● ●	● ● ● ● ● ● ● ●
Nitric Acid	65	● ● ● ● ● ● ● ●	● ● ● ● ● ● ● ●
Palmitic Acid	-	● ● ● ● ● ● ● ●	● ● ● ● ● ● ● ●
Salicylic Acid	-	● ● ● ● ● ● ● ●	● ● ● ● ● ● ● ●
Stearic Acid	-	● ● ● ● ● ● ● ●	● ● ● ● ● ● ● ●
Sulfhydic Acid	10	● ● ● ● ● ● ● ●	● ● ● ● ● ● ● ●
Sulfhydic Acid	20	● ● ● ● ● ● ● ●	● ● ● ● ● ● ● ●
Sulfuric Acid	25	● ● ● ● ● ● ● ●	● ● ● ● ● ● ● ●
Sulfuric Acid	50	● ● ● ● ● ● ● ●	● ● ● ● ● ● ● ●
Sulfuric Acid	60	● ● ● ● ● ● ● ●	● ● ● ● ● ● ● ●
Sulfuric Acid	75	● ● ● ● ● ● ● ●	● ● ● ● ● ● ● ●
Sulfuric Acid	96	● ● ● ● ● ● ● ●	● ● ● ● ● ● ● ●
Sulfurous Acid	-	● ● ● ● ● ● ● ●	● ● ● ● ● ● ● ●
Tannic Acid	-	● ● ● ● ● ● ● ●	● ● ● ● ● ● ● ●
Tartaric Acid	10	● ● ● ● ● ● ● ●	● ● ● ● ● ● ● ●
Deionized Water	-	● ● ● ● ● ● ● ●	● ● ● ● ● ● ● ●
Turpentine	-	● ● ● ● ● ● ● ●	● ● ● ● ● ● ● ●
Acrylonitrile	-	● ● ● ● ● ● ● ●	● ● ● ● ● ● ● ●
Ammonia	-	● ● ● ● ● ● ● ●	● ● ● ● ● ● ● ●
Aniline	-	● ● ● ● ● ● ● ●	● ● ● ● ● ● ● ●
Aniline	-	● ● ● ● ● ● ● ●	● ● ● ● ● ● ● ●
Asphalt	-	● ● ● ● ● ● ● ●	● ● ● ● ● ● ● ●
ASTM 1 OIL	-	● ● ● ● ● ● ● ●	● ● ● ● ● ● ● ●
ASTM 2 OIL	-	● ● ● ● ● ● ● ●	● ● ● ● ● ● ● ●
ASTM 3 OIL	-	● ● ● ● ● ● ● ●	● ● ● ● ● ● ● ●
Benzene	-	● ● ● ● ● ● ● ●	● ● ● ● ● ● ● ●
Sodium Bicarbonate	-	● ● ● ● ● ● ● ●	● ● ● ● ● ● ● ●
Carbon Dioxide	-	● ● ● ● ● ● ● ●	● ● ● ● ● ● ● ●
Butter	-	● ● ● ● ● ● ● ●	● ● ● ● ● ● ● ●
Butadiene	-	● ● ● ● ● ● ● ●	● ● ● ● ● ● ● ●
Liquid Butane	-	● ● ● ● ● ● ● ●	● ● ● ● ● ● ● ●
Fuel A (Isooctane 100%)	-	● ● ● ● ● ● ● ●	● ● ● ● ● ● ● ●
Fuel B (Isooct. 70% Toluene 30)	-	● ● ● ● ● ● ● ●	● ● ● ● ● ● ● ●
Fuel C (Isooct. 50% Toluene 50)	-	● ● ● ● ● ● ● ●	● ● ● ● ● ● ● ●
Fuel with Methanol or Ethanol	-	● ● ● ● ● ● ● ●	● ● ● ● ● ● ● ●
Kerosene	-	● ● ● ● ● ● ● ●	● ● ● ● ● ● ● ●
Cyclohexane	-	● ● ● ● ● ● ● ●	● ● ● ● ● ● ● ●
Chloroacetone	-	● ● ● ● ● ● ● ●	● ● ● ● ● ● ● ●
Chloroform	-	● ● ● ● ● ● ● ●	● ● ● ● ● ● ● ●
Chloroprene	-	● ● ● ● ● ● ● ●	● ● ● ● ● ● ● ●
Dry Chlorine	-	● ● ● ● ● ● ● ●	● ● ● ● ● ● ● ●
Wet Chlorine	-	● ● ● ● ● ● ● ●	● ● ● ● ● ● ● ●
Dibutyl Phthalate	-	● ● ● ● ● ● ● ●	● ● ● ● ● ● ● ●
Diethylene Glycol	-	● ● ● ● ● ● ● ●	● ● ● ● ● ● ● ●
Diethyl Sebacate	-	● ● ● ● ● ● ● ●	● ● ● ● ● ● ● ●
Dinitrotoluene	-	● ● ● ● ● ● ● ●	● ● ● ● ● ● ● ●
Diocetyl Phthalate	-	● ● ● ● ● ● ● ●	● ● ● ● ● ● ● ●
Diocetyl Sebacate	-	● ● ● ● ● ● ● ●	● ● ● ● ● ● ● ●
Epichlorohydrin	-	● ● ● ● ● ● ● ●	● ● ● ● ● ● ● ●
Hexane	-	● ● ● ● ● ● ● ●	● ● ● ● ● ● ● ●
Ethanol	-	● ● ● ● ● ● ● ●	● ● ● ● ● ● ● ●
Fluorobenzene	-	● ● ● ● ● ● ● ●	● ● ● ● ● ● ● ●
Liquid Fluorine	-	● ● ● ● ● ● ● ●	● ● ● ● ● ● ● ●
Formaldehyde	40	● ● ● ● ● ● ● ●	● ● ● ● ● ● ● ●
Formaldehyde	40	● ● ● ● ● ● ● ●	● ● ● ● ● ● ● ●
Freon 11	-	● ● ● ● ● ● ● ●	● ● ● ● ● ● ● ●
Freon 12	-	● ● ● ● ● ● ● ●	● ● ● ● ● ● ● ●
Freon 21	-	● ● ● ● ● ● ● ●	● ● ● ● ● ● ● ●
Freon 22	-	● ● ● ● ● ● ● ●	● ● ● ● ● ● ● ●
Freon 113	-	● ● ● ● ● ● ● ●	● ● ● ● ● ● ● ●
Freon 114	-	● ● ● ● ● ● ● ●	● ● ● ● ● ● ● ●
Glycerine	-	● ● ● ● ● ● ● ●	● ● ● ● ● ● ● ●
Silicone Grease	-	● ● ● ● ● ● ● ●	● ● ● ● ● ● ● ●
Hydrogen	-	● ● ● ● ● ● ● ●	● ● ● ● ● ● ● ●
Calcium Hydroxide	-	● ● ● ● ● ● ● ●	● ● ● ● ● ● ● ●
Sodium Hypochlorite	10	● ● ● ● ● ● ● ●	● ● ● ● ● ● ● ●
Milk	-	● ● ● ● ● ● ● ●	● ● ● ● ● ● ● ●
Mercury	-	● ● ● ● ● ● ● ●	● ● ● ● ● ● ● ●
Methanol	-	● ● ● ● ● ● ● ●	● ● ● ● ● ● ● ●
Methyl Ethyl Ketone	-	● ● ● ● ● ● ● ●	● ● ● ● ● ● ● ●
Naphtha	-	● ● ● ● ● ● ● ●	● ● ● ● ● ● ● ●
Nitrobenzene	-	● ● ● ● ● ● ● ●	● ● ● ● ● ● ● ●
Nitroethane	-	● ● ● ● ● ● ● ●	● ● ● ● ● ● ● ●
Nitromethane	-	● ● ● ● ● ● ● ●	● ● ● ● ● ● ● ●
Nitropropane	-	● ● ● ● ● ● ● ●	● ● ● ● ● ● ● ●
Animal Oil (Whale-Seal)	-	● ● ● ● ● ● ● ●	● ● ● ● ● ● ● ●
Grain Oil	-	● ● ● ● ● ● ● ●	● ● ● ● ● ● ● ●
Coconut Oil	-	● ● ● ● ● ● ● ●	● ● ● ● ● ● ● ●
Cod-Liver Oil	-	● ● ● ● ● ● ● ●	● ● ● ● ● ● ● ●
Olive Oil	-	● ● ● ● ● ● ● ●	● ● ● ● ● ● ● ●
Cottonseed Oil	-	● ● ● ● ● ● ● ●	● ● ● ● ● ● ● ●
Silicon Oil	-	● ● ● ● ● ● ● ●	● ● ● ● ● ● ● ●
Castor Oil	-	● ● ● ● ● ● ● ●	● ● ● ● ● ● ● ●
Oxygen	-	● ● ● ● ● ● ● ●	● ● ● ● ● ● ● ●
Ozone	-	● ● ● ● ● ● ● ●	● ● ● ● ● ● ● ●
Perchloroethylene	-	● ● ● ● ● ● ● ●	● ● ● ● ● ● ● ●
Potassium Permanganate	25	● ● ● ● ● ● ● ●	● ● ● ● ● ● ● ●
Tetraethyl Lead	-	● ● ● ● ● ● ● ●	● ● ● ● ● ● ● ●
Propane	-	● ● ● ● ● ● ● ●	● ● ● ● ● ● ● ●
Soda (Sodium Hydroxide)	10	● ● ● ● ● ● ● ●	● ● ● ● ● ● ● ●
Styrene	-	● ● ● ● ● ● ● ●	● ● ● ● ● ● ● ●
Toluene	-	● ● ● ● ● ● ● ●	● ● ● ● ● ● ● ●
Trichloroethylene	-	● ● ● ● ● ● ● ●	● ● ● ● ● ● ● ●
Sulfur	-	● ● ● ● ● ● ● ●	● ● ● ● ● ● ● ●

The data shown in the table are approximate

ELASTOMERS		NR	SBR	EPDM	NBR	CR	CSM	VMQ	FKM	
Specific weight		0.93	0.95	0.86	0.97	1.25	1.2	1.2	1.82	
Hardness	(Shore A)	25:95	35:95	40:85	30:90	25:90	40:90	30:80	50:90	
Tensile strength	(M Pa)	14:30	7:28	6:18	7:25	7:24	12:24	4:9	5:17	
Ultimate elongation	(%)	150:850	125:850	150:500	150:750	100:800	150:500	400:600	125:300	
Resilience	(%)	30:65	25:55	35:55	10:50	20:50	5:20	40:55	5:10	
Extreme operating temperatures		(°C)	-45:85	-40:90	-40:155	-40:110	-40:100	-15:120	-50:225	-20:250
Abrasion resistance		●	●●	●	●	●●	●●	●	●●	
Gas impermeability		●	●●	●	●●	●	●	●	●	

Class	Behaviour
●	recommended
●	satisfactory
●	unsatisfactory
●	not recommended

- NR** = NATURAL RUBBER
- SBR** = STYRENE-BUTADIENE RUBBER
- EPDM** = ETHYLENE-PROPYLENE THERMOPOLYMER
- NBR** = NITRILE RUBBER
- CR** = POLYCHLOROPRENE
- CSM** = CHLOROSULPHONATED POLYETHYLENE
- VMQ** = SILICONE RUBBER
- FKM** = FLUOROCARBON RUBBER (VITON®)

VITON® is a registered trademark of Dupont Dow Elastomers L.L.C.

### Specifications of **TEFLON®** (Virgin PTFE)

Properties	U.m.	Values (from-to)
Specific weight	-	2.14 - 2.20
Ultimate strength	N/mm <sup>2</sup>	20 - 35
Ultimate elongation	%	210 - 400
Compressive strength 1% deformat.	N/mm <sup>2</sup>	4.00 - 4.50
Flexural strength 0.7 N/mm <sup>2</sup>	N/mm <sup>2</sup>	no breakage
Shock resistance 57°C	J/cm	1,1
Shock resistance 23°C	J/cm	1,6
Shock resistance 77°C	J/cm	3,3
Hardness	(shoreD)	50 - 60
Static friction coefficient	-	0,09
Dynamic friction coefficient	-	0,05
PTFE - oil-lubricated steel	-	0,02 - 0,06
Coefficient of expansion from 25 to 100°C	°C <sup>-1</sup>	16 x 10 <sup>-5</sup>
Thermal conductivity	W/mK	0,2
Distortion temperatures 0.46 N/mm <sup>2</sup>	°C	130 - 140
Distortion temperatures 1.85 N/mm <sup>2</sup>	°C	50 - 60
Water absorption	%	<0,01
Inflammability ATB	sec	<5,00
Inflammability AEB	mm	<5,00
Operating temperature	°C	-200 +260

The data shown in the table are approximate

TEFLON® is a registered trademark of E.I. Dupont De Nemours & Co.

ISO METRIC		
<b>M</b>		
Thread Diameter	Drill Hole Diameter	
mm	mm	
M 1 x 0,25	0,75	
M 1,1 x 0,25	0,85	
M 1,2 x 0,25	0,95	
M 1,4 x 0,30	1,1	
M 1,6 x 0,35	1,25	
M 1,8 x 0,35	1,45	
M 2 x 0,4	1,6	
M 2,2 x 0,45	1,75	
M 2,5 x 0,45	2,05	
M 3 x 0,5	2,5	
M 3,5 x 0,6	2,9	
M 4 x 0,7	3,3	
M 4,5 x 0,75	3,7	
M 5 x 0,8	4,2	
M 6 x 1	5	
M 7 x 1	6	
M 8 x 1,25	6,8	
M 9 x 1,25	7,8	
M 10 x 1,5	8,5	
M 11 x 1,5	9,5	
M 12 x 1,75	10,2	
M 14 x 2	12	
M 16 x 2	14	
M 18 x 2,5	15,5	
M 20 x 2,5	17,5	
M 22 x 2,5	19,5	
M 24 x 3	21	
M 27 x 3	24	
M 30 x 3,5	26,5	
M 33 x 3,5	29,5	
M 36 x 4	32	
M 39 x 4	35	
M 42 x 4,5	37,5	
M 45 x 4,5	40,5	
M 48 x 5	43	
M 52 x 5	47	
M 56 x 5,5	50,5	

ISO METRIC FINE					
<b>MF</b>					
Thread Diameter	Drill Hole Diameter		Thread Diameter	Drill Hole Diameter	
mm	mm		mm	mm	
M 1 x 0,2	0,75		M 24 x 2	22	
M 1,1 x 0,2	0,9		M 25 x 1	24	
M 1,2 x 0,2	1		M 25 x 1,5	23,5	
M 1,4 x 0,2	1,2		M 25 x 2	23	
M 1,4 x 0,25	1,15		M 26 x 1,5	24,5	
M 1,6 x 0,2	1,4		M 27 x 1	26	
M 1,8 x 0,2	1,6		M 27 x 1,5	25,5	
M 2 x 0,25	1,75		M 27 x 2	25	
M 2,2 x 0,25	1,95		M 28 x 1	27	
M 2,5 x 0,35	2,15		M 28 x 1,5	26,5	
M 3 x 0,35	2,65		M 28 x 2	26	
M 3,5 x 0,35	3,15		M 30 x 1	29	
M 4 x 0,35	3,65		M 30 x 1,5	28,5	
M 4 x 0,5	3,5		M 30 x 2	28	
M 4,5 x 0,5	4		M 30 x 3	27	
M 5 x 0,5	4,5		M 32 x 1,5	30,5	
M 5,5 x 0,5	5		M 32 x 2	30	
M 6 x 0,75	5,2		M 33 x 1,5	31,5	
M 7 x 0,75	6,2		M 33 x 2	31	
M 8 x 1	7		M 33 x 3	30	
M 8 x 0,75	7,2		M 35 x 1,5	33,5	
M 9 x 1	8		M 36 x 1,5	34,5	
M 9 x 0,75	8,2		M 36 x 2	34	
M 10 x 1	9		M 36 x 3	33	
M 10 x 0,75	9,2		M 38 x 1,5	36,5	
M 10 x 1,25	8,8		M 39 x 1,5	37,5	
M 11 x 1	10		M 39 x 2	37	
M 11 x 0,75	10,2		M 39 x 3	36	
M 12 x 1	11		M 40 x 1,5	38,5	
M 12 x 1,25	10,8		M 40 x 2	38	
M 12 x 1,5	10,5		M 40 x 3	37	
M 14 x 1	13		M 42 x 1,5	40,5	
M 14 x 1,25	12,8		M 42 x 2	40	
M 14 x 1,5	12,5		M 42 x 3	39	
M 15 x 1	14		M 42 x 4	38	
M 15 x 1,5	13,5		M 45 x 1,5	43,5	
M 16 x 1	15		M 45 x 2	43	
M 16 x 1,5	14,5		M 45 x 3	42	
M 17 x 1	16		M 45 x 4	41	
M 17 x 1,5	15,5		M 48 x 1,5	46,5	
M 18 x 1	17		M 48 x 2	46	
M 18 x 1,5	16,5		M 48 x 3	45	
M 18 x 2	16		M 48 x 4	44	
M 20 x 1	19		M 50 x 1,5	48,5	
M 20 x 1,5	18,5		M 50 x 2	48	
M 20 x 2	18		M 50 x 3	47	
M 22 x 1	21		M 52 x 1,5	50,5	
M 22 x 1,5	20,5		M 52 x 2	50	
M 22 x 2	20		M 52 x 3	49	
M 24 x 1	23		M 52 x 4	48	
M 24 x 1,5	22,5				

WHITWORTH W <b>BSW</b>	
Nominal Thread Diameter	Drill Hole Diameter
Inches	mm
1/8 - 40	2,55
5/32 - 32	3,2
3/16 - 24	3,7
1/4 - 20	5,1
5/16 - 18	6,5
3/8 - 16	7,9
7/16 - 14	9,2
1/2 - 12	10,5
9/16 - 12	12
5/8 - 11	13,5
3/4 - 10	16,25
7/8 - 9	19,25
1 - 8	21,75
1 1/8 - 7	24,75
1 1/4 - 7	27,75
1 3/8 - 6	30,5
1 1/2 - 6	33,5
1 5/8 - 5	35,5
1 3/4 - 5	39
2 - 4 1/2	44,5
2 1/4 - 4	50
2 1/2 - 4	56,5
2 3/4 - 3 1/2	62
3 - 3 1/2	62

WHITWORTH GAS <b>BSP</b>	
Nominal Thread Diameter	Drill Hole Diameter
Inches	mm
G 1/8 - 28	8,8
G 1/4 - 19	11,8
G 3/8 - 19	15,25
G 1/2 - 14	19
G 5/8 - 14	21
G 3/4 - 14	24,5
G 7/8 - 14	28,25
G 1 - 11	30,75
G 1 1/8 - 11	35,3
G 1 1/4 - 11	39,25
G 1 3/8 - 11	41,9
G 1 1/2 - 11	45,25
G 1 3/4 - 11	51,3
G 2 - 11	57
G 2 1/4 - 11	63,1
G 2 1/2 - 11	72,6
G 2 3/4 - 11	79,1
G 3 - 11	85,5
G 3 1/4 - 11	91,5
G 3 1/2 - 11	97,7
G 3 3/4 - 11	104
G 4 - 11	110,5

TAPERED GAS <b>BSPT</b>	
Nominal Thread Diameter	Drill Hole Diameter
Inches	mm
1/8 - 28	8,4
1/4 - 19	11,2
3/8 - 19	14,75
1/2 - 14	18,25
3/4 - 14	23,75
1 - 11	30
1 1/4 - 11	38,5
1 1/2 - 11	44,5
2 - 11	56
2 1/2 - 11	71,5

AMERICAN <b>NPT</b>	
Nominal Thread Diameter	Drill Hole Diameter
Inches	mm
1/6 - 27	6,25
1/8 - 27	8,5
1/4 - 18	11
3/8 - 18	14,5
1/2 - 14	18
3/4 - 14	23
1 - 11 1/2	29
1 1/4 - 11 1/2	38
1 1/2 - 11 1/2	44
2 - 11 1/2	56
2 1/2 - 8	67

UNIFIED COARSE THREAD <b>UNC</b>	
Nominal Thread Diameter	Drill Hole Diameter
Inches	mm
Nr. 1 - 64	1,5
Nr. 2 - 56	1,8
Nr. 3 - 48	2,02
Nr. 4 - 40	2,25
Nr. 5 - 40	2,6
Nr. 6 - 32	2,75
Nr. 8 - 32	3,4
Nr. 10 - 24	3,8
Nr. 12 - 24	4,5
1/4 - 20	5,1
5/46 - 18	6,5
3/8 - 16	8
7/16 - 14	9,4
1/2 - 13	10,75
9/16 - 12	12,2
5/8 - 11	13,6
3/4 - 10	16,5
7/8 - 9	19,5
1 - 8	22,25
1 1/8 - 7	25
1 1/4 - 7	28,25
1 3/8 - 6	30,75
1 1/2 - 6	34
1 3/4 - 5	39,5
2 - 4 1/2	45

UNIFIED COARSE THREAD <b>UNF</b>	
Nominal Thread Diameter	Drill Hole Diameter
Inches	mm
Nr. 0 - 80	1,25
Nr. 1 - 72	1,55
Nr. 2 - 64	1,85
Nr. 3 - 56	2,1
Nr. 4 - 48	2,35
Nr. 5 - 44	2,65
Nr. 6 - 40	2,9
Nr. 8 - 36	3,5
Nr. 10 - 32	4,1
Nr. 12 - 28	4,6
1/4 - 28	5,5
5/16 - 24	6,9
3/8 - 24	8,5
7/16 - 20	9,9
1/2 - 20	11,5
9/16 - 18	12,9
5/8 - 18	14,5
3/4 - 16	17,5
7/8 - 14	20,5
1 - 12	23,25
1 1/8 - 12	26,5
1 1/4 - 12	29,75
1 3/8 - 12	33
1 1/2 - 12	36

AMERICAN <b>NPTF</b>	
Nominal Thread Diameter	Drill Hole Diameter
Inches	mm
1/6 - 27	6,15
1/8 - 27	8,4
1/4 - 18	10,9
3/8 - 18	14,25
1/2 - 14	17,75
3/4 - 14	23
1 - 11 1/2	29
1 1/4 - 11 1/2	37,75
1 1/2 - 11 1/2	43,75
2 - 11 1/2	55,75
2 1/2 - 8	66,5

**DRILL HOLES FOR ROLL FORM TAPS**

ISO METRIC <b>M</b>		
Thread Diameter	Drill Hole Diameter	
mm	mm	
M 1 x 0.25	0,9	
M 1,2 x 0.25	1,1	
M 1,4 x 0,3	1,25	
M 1,6 x 0.35	1,45	
M 1,8 x 0.35	1,65	
M 2 x 0.4	1,8	
M 2,5 x 0.45	2,3	
M 3 x 0,5	2,8	
M 3,5 x 0,6	3,2	
M 4 x 0,7	3,7	
M 5 x 0,8	4,6	
M 6 x 1	5,5	
M 7 x 1	6,5	
M 8 x 1.25	7,4	
M 10 x 1,5	9,3	
M 12 x 1.75	11,2	
M 14 x 2	13	
M 16 x 2	15	

UNIFIED COARSE THREAD <b>UNC</b>		
Nominal Thread Diameter	Drill Hole Diameter	
Inches	mm	
Nr. 1 - 64	1,7	
Nr. 2 - 56	2	
Nr. 3 - 48	2,3	
Nr. 4 - 40	2,6	
Nr. 5 - 40	2,9	
Nr. 6 - 32	3,2	
Nr. 8 - 32	3,8	
Nr. 10 - 24	4,4	
Nr. 12 - 24	5	
1/4 - 20	5,8	
5/16 - 18	7,3	
3/8 - 16	8,8	
7/16 - 14	10,3	
1/2 - 13	11,9	

ISO METRIC FINE <b>MF</b>		
Thread Diameter	Drill Hole Diameter	
mm	mm	
M 4 x 0.5	3,5	
M 5 x 0,5	4,5	
M 6 x 0.75	5,2	
M 8 x 0.75	7,2	
M 8 x 1	7,2	
M 10 x 1	9	
M 10 x 1.25	8,8	
M 12 x 1	11	
M 12 x 1.25	10,8	
M 12 x 1.5	10,5	
M 14 x 1	13	
M 14 x 1.25	12,8	
M 14 x 1,5	12,5	
M 16 x 1	15	
M 16 x 1,5	14,5	

UNIFIED COARSE THREAD <b>UNF</b>		
Nominal Thread Diameter	Drill Hole Diameter	
Inches	mm	
Nr. 1 - 72	1,7	
Nr. 2 - 64	2	
Nr. 3 - 56	2,3	
Nr. 4 - 48	2,6	
Nr. 5 - 44	2,9	
Nr. 6 - 40	3,2	
Nr. 8 - 36	3,9	
Nr. 10 - 32	4,5	
Nr. 12 - 28	5,1	
1/4 - 28	6	
5/16 - 24	7,5	
3/8 - 24	9,1	
7/16 - 20	10,6	
1/2 - 20	12,1	

# VIVOIL OLEODINAMICA VIVOLO

s.r.l. Società a Socio Unico

Via Leone Ginzburg 2-4 - 40054 Cento di Budrio (BO) - ITALY - TEL. +39 - 051.803689 Fax +39 - 051.800061

Partita Iva e cod. Fiscale 03542620376 C.C.I.A.A. 299009 - Iscr. Trib.: BO 43434

WEB: [www.vivoil.com](http://www.vivoil.com) E-mail [vivoil@vivoil.com](mailto:vivoil@vivoil.com)

®

